

Quality assurance for computed-tomography simulators and the computed-tomography-simulation process: Report of the AAPM Radiation Therapy Committee Task Group No. 66

Sasa Mutic^{a)}

Department of Radiation Oncology, Washington University School of Medicine, St. Louis, Missouri 63110

Jatinder R. Palta

Department of Radiation Oncology, University of Florida, Gainesville, Florida 32610

Elizabeth K. Butker

Department of Radiation Oncology, Emory University School of Medicine, Atlanta, Georgia

Indra J. Das

Department of Radiation Oncology, University of Pennsylvania, Philadelphia, Pennsylvania 19104

M. Saiful Huq

Department of Radiation Oncology, Thomas Jefferson University Hospital, Philadelphia, Pennsylvania 19107

Leh-Nien Dick Loo

Department of Medical Physics, Kaiser Permanente, Los Angeles, California 90039

Bill J. Salter

Department of Radiation Oncology, University of Texas Health Sciences Center, San Antonio, Texas 78229

Cynthia H. McCollough^{b)}

Department of Radiology, Mayo Clinic, Rochester, Minnesota 55905

Jacob Van Dyk^{b)}

Department of Clinical Physics, London Regional Cancer Center, London, Ontario N6A 4L6, Canada

(Received 21 April 2003; revised 1 July 2003; accepted for publication 25 July 2003; published 24 September 2003)

This document presents recommendations of the American Association of Physicists in Medicine (AAPM) for quality assurance of computed-tomography- (CT) simulators and CT-simulation process. This report was prepared by Task Group No. 66 of the AAPM Radiation Therapy Committee. It was approved by the Radiation Therapy Committee and by the AAPM Science Council. © 2003 American Association of Physicists in Medicine. [DOI: 10.1118/1.1609271]

PREFACE

The purpose of this document is to provide the medical physicist with a framework and guidance for establishment of a comprehensive quality assurance (QA) program for computed-tomography- (CT) scanners used for CT-simulation, CT-simulation software, and the CT-simulation process. The CT-simulator is a CT scanner equipped with a flat tabletop and, preferably, external patient positioning lasers. The scanner is accompanied with specialized software which allows treatment planning on volumetric patient CT scans in a manner consistent with conventional radiation therapy simulators.¹⁻¹² The CT scanner used in the CT-simulation process can be located in the radiation oncology department or in the diagnostic radiology department. Depending on the CT-scanner location and primary use, acceptance testing, commissioning, and QA can be the responsibility of a therapy medical physicist, diagnostic physicist, or a joint responsibility of diagnostic and therapy physicists. The commissioning and periodic QA of the accompanying software and the QA of the CT-simulation process is always the responsibility of the therapy physicist. This report does not address each of the two scenarios individually (scanner located in diagnostic radiology or radiation oncology), but

rather establishes a set of QA procedures that are applicable to scanners used for CT-simulation regardless of their location and primary purpose. It is the responsibility of the respective diagnostic and therapy physicists to determine how the QA program is implemented and how the responsibilities are assigned. The primary responsibility for implementation of recommendations for QA of scanners used for CT-simulation in this document rests with the radiation oncology Quality Assurance Committee (QAC) as specified by the AAPM Task Group 40.¹³ Further discussion of QA program responsibilities is provided in Appendix A. If the scanner is located in the radiation oncology department, a therapy medical physicist can perform QA of the CT-scanner and of the simulation process independently. It is recommended that the therapy physicist solicit help from a diagnostic physicist for the establishment of a QA program and scanner commissioning if he or she has limited CT experience. Likewise, if the CT-scanner is located in the diagnostic radiology department, the primary responsibility for the scanner QA rests with the diagnostic physicist. It is then the responsibility of the radiation oncology physicist to assure that the recommendations of this task group are implemented by either diagnostic radiology or the radiation oncology physicist or a designate.

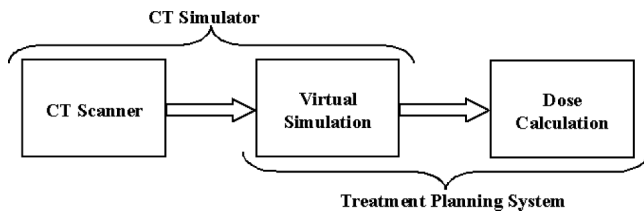

FIG. 1. Block diagram showing relevant components of CT-simulation and treatment planning systems.

Figure 1 shows the place of CT-simulation in the treatment planning process. CT-simulation includes the CT-scanner and components of treatment planning system and provides input for dose calculation. Therefore, the subject matter addressed in this document overlaps with the AAPM Diagnostic X-Ray Imaging Committee Task Group 2¹⁴ report (Specification and acceptance testing of computed tomography scanners; AAPM Report No. 39) and the report of the AAPM Radiation Therapy Committee Task Group 53¹⁵ (Quality assurance for clinical radiotherapy treatment planning). The aim of the current task group was not to duplicate material presented in the other two reports, but to develop a set of QA guidelines specific to CT-simulation, and to complement the recommendations presented in the other two reports. This document was prepared with the intent that it would be used in conjunction with the other two reports. When a topic is discussed by the current task group, which is also addressed in Report No. 39 or the TG53 report, this document provides a description of the QA requirements and the reader is then referred to the report in which this topic was discussed in greater detail. In situations when the other two reports do not address a topic regarding QA requirements for CT-simulation, this document discusses these requirements. The current report was primarily intended for radiation oncology physicists who may have limited CT experience; therefore, the description of QA procedures for CT-scanners is substantially more extensive than our discussion of CT-simulation software QA. It is expected that the therapy physicist is familiar with the TG53 QA recommendations and procedures for testing of treatment planning software. Most of the QA procedures presented in this document have already been described in literature. Whenever possible we refer the reader to appropriate references. A summary of recommended QA tests, frequencies, and tolerances is presented

in Tables I, II, and III. These tables are intended as an overview of topics included in this document and respective recommendations.

This report also does not address QA requirements for the scanner nor for software vendors. The QA tasks associated with the scanner design, simulation software engineering, testing, validation, upgrades, preventive maintenance, or other tasks performed by vendors are numerous and differ significantly among each other and are beyond the scope of this task group. The report also does not address CT-scanning and related QA procedures for special procedures in radiation oncology like stereotactic radiosurgery or image-guided brachytherapy. The procedures outlined in the report are designed primarily for purposes of external beam radiotherapy.

The report refers to several commercially available devices. These descriptions are intended to be examples of available equipment. This should not be interpreted as our recommendation or endorsement of these products. It is the responsibility of the medical institution and medical physicist to research the market when purchasing equipment.

Terminology used in this report is modeled after that used in other AAPM task group reports:

- *Shall or must* are used when the activity is required by various regulatory agencies,
- *Recommend* is used when the task group expects that the procedure should normally be followed as described. However, there may be instances where other issues, techniques or priorities could force the modification of the task group recommendation.
- *Should* is used when it is expected that local analysis of the situation may change the way a particular activity is performed.

The tests described in this document address issues of patient, staff, public, and medical center safety. The tests are designed to assure proper equipment and program operation, which is directly related to the quality of patient care. Medical physicists and the medical center should make every effort to implement procedures outlined in this document. We have tried to design a CT-simulation QA program that is economically feasible and practical and one that should not be unreasonably burdensome to implement. The QA program should improve quality and efficiency of the treatment plan-

TABLE I. Test specifications for radiation and patient safety.

Performance parameter	Test objective	Frequency	Tolerance limits
Shielding survey	To verify exposure levels around the CT-scanner room	Initially	NCRP recommendations or applicable regulatory limits
Patient dose from CT-scan, CTDI	To verify safe dose delivered from the scanner	Annually or after major CT-scanner component replacement	± 20% of manufacturer specifications

ning process and avoid mistakes costly to both patients and the medical institution.

TABLE OF CONTENTS

I. OVERVIEW.....	2764	3. Multimodality image registration.....	2776
A. CT-simulation process.....	2764	4. Machine definition.....	2776
1. CT-scan, patient positioning and immobilization.....	2766	5. Isocenter calculation and movement.....	2778
2. Treatment planning and CT-simulation.....	2766	6. Image reconstruction.....	2778
3. Treatment setup.....	2767	B. Evaluation of digitally reconstructed radiographs (DRRs).....	2778
B. Quality assurance program goals.....	2767	1. Spatial and contrast resolution.....	2778
1. Safety of patients, public, and hospital staff.....	2767	2. Geometric and spatial accuracy.....	2778
2. Accurate target localization and treatment simulation.....	2768	3. Hardcopy quality.....	2778
II. FUNCTIONAL PERFORMANCE CHARACTERISTICS OF CT EQUIPMENT.....	2768	C. Periodic quality assurance testing.....	2778
A. Overview of a CT-scanner and a virtual simulation system.....	2768	V. EVALUATION OF THE CT-SIMULATION PROCESS.....	2779
1. X-ray tube.....	2768	A. Overall process tests.....	2779
2. Collimator and attenuator.....	2768	B. Data transfer tests.....	2780
3. Patient support table.....	2768	VI. CONCLUSIONS.....	2781
4. Computer and workstation.....	2769	APPENDIX A: INFORMATION FOR HOSPITAL ADMINISTRATION.....	2781
5. External patient marking/positioning lasers.....	2769	1. Information for radiation oncology administration.....	2781
B. Conventional and spiral CT.....	2769	2. Information for diagnostic radiology administration.....	2783
C. Multislice scanners.....	2769	APPENDIX B: CT DOSIMETRY.....	2783
D. Large bore scanners.....	2769	1. CT dose descriptors.....	2783
E. CT performance parameters.....	2770	2. CT dose measurements.....	2784
III. QUALITY ASSURANCE FOR CT-SCANNERS USED FOR CT-SIMULATION AND ITS FREQUENCY.....	2770	APPENDIX C: RADIATION SAFETY SURVEY/SHIELDING EVALUATION.....	2785
A. CT dosimetry.....	2770	APPENDIX D: CT-SIMULATOR LASER QA.....	2785
B. Radiation/patient safety.....	2770	APPENDIX E: SCANNER TABLE TESTS.....	2788
C. Performance of electromechanical components.....	2770	APPENDIX F: X-RAY GENERATOR TESTS.....	2789
1. Patient marking/positioning lasers.....	2770	APPENDIX G: SAMPLE OVERALL CT-SIMULATOR PROCESS TEST.....	2790
2. Couch and tabletop.....	2771		
3. Gantry tilt.....	2772		
4. Scan localization from scout image (topogram, pilot image).....	2772		
5. Collimation.....	2772		
6. X-ray generator.....	2773		
D. Image quality tests.....	2773		
1. Random uncertainty in pixel value (noise).....	2773		
2. Systematic uncertainty—field uniformity.....	2773		
3. Quantitative CT.....	2774		
4. Spatial integrity.....	2775		
5. Spatial resolution.....	2775		
6. Contrast resolution.....	2775		
IV. QUALITY ASSURANCE FOR CT-SIMULATION SOFTWARE AND ITS FREQUENCY.....	2776		
A. Spatial/geometry accuracy tests.....	2776		
1. Image input tests.....	2776		
2. Structure delineation.....	2776		

I. OVERVIEW

A. CT-simulation process

A CT-simulator consists of a CT-scanner with a flat table top, laser patient positioning and marking system (preferably external lasers), CT-simulation/3D treatment planning software, and various hardcopy output devices (Fig. 2). The CT-scanner is used to acquire a volumetric CT-scan of a patient, which represents the “virtual” or digital patient. The CT-simulation software provides virtual representations of the geometric capabilities of a treatment machine. This software can be a special virtual simulation program or it can be a component of a treatment planning system. Often, CT-simulation is referred to as virtual simulation and the two terms tend to be used interchangeably. Virtual simulation is used to define any simulation based on software created “virtual simulator” and a volumetric patient scan. The scan does not necessarily have to be CT and other imaging modalities can be used. A virtual simulator is a set of software which recreates the treatment machine and which allows import, manipulation, display, and storage of images from CT and/or other imaging modalities. CT-simulator components and their features are described in Secs. II, III, and IV. CT-simulation process has been described by several authors.^{1–4,6,9–12,14,16} This process and its implementation

TABLE II. Test specifications for electromechanical components.^a

Performance parameter	Test objective	Frequency	Tolerance limits
Alignment of gantry lasers with the center of imaging plane	To verify proper identification of scan plane with gantry lasers	Daily	± 2 mm
Orientation of gantry lasers with respect to the imaging plane	To verify that the gantry lasers are parallel and orthogonal with the imaging plane over the full length of laser projection	Monthly and after laser adjustments	± 2 mm over the length of laser projection
Spacing of lateral wall lasers with respect to lateral gantry lasers and scan plane	To verify that lateral wall lasers are accurately spaced from the scan plane. This distance is used for patient localization marking	Monthly and after laser adjustments	± 2 mm
Orientation of wall lasers with respect to the imaging plane	To verify that the wall lasers are parallel and orthogonal with the imaging plane over the full length of laser projection	Monthly and after laser adjustments	± 2 mm over the length of laser projection
Orientation of the ceiling laser with respect to the imaging plane	To verify that the ceiling laser is orthogonal with the imaging plane	Monthly and after laser adjustments	± 2 mm over the length of laser projection
Orientation of the CT-scanner tabletop with respect to the imaging plane	To verify that the CT-scanner tabletop is level and orthogonal with the imaging plane	Monthly or when daily laser QA tests reveal rotational problems	± 2 mm over the length and width of the tabletop
Table vertical and longitudinal motion	To verify that the table longitudinal motion according to digital indicators is accurate and reproducible	Monthly	± 1 mm over the range of table motion
Table indexing and position	To verify table indexing and position accuracy under scanner control	Annually	± 1 mm over the scan range
Gantry tilt accuracy	To verify accuracy of gantry tilt indicators	Annually	$\pm 1^\circ$ over the gantry tilt range
Gantry tilt position accuracy	To verify that the gantry accurately returns to nominal position after tilting	Annually	$\pm 1^\circ$ or ± 1 mm from nominal position
Scan localization	To verify accuracy of scan localization from pilot images	Annually	± 1 mm over the scan range

TABLE II. (Continued.)

Performance parameter	Test objective	Frequency	Tolerance limits
Radiation profile width	To verify that the radiation profile width meets manufacturer specification	Annually (This test is optional if the CTDI accuracy has been verified)	Manufacturer specifications
Sensitivity profile width	To verify that the sensitivity profile width meets manufacturer specification	Semiannually	± 1 mm of nominal value
Generator tests	To verify proper operation of the x-ray generator	After replacement of major generator component	Manufacturer specifications or Report No. 39 recommendations

^aDepending on the goals and prior clinical experience of a particular CT-simulation program, these tests, frequencies, and tolerances may be modified by the medical physicist.

vary among institutions. The simulation process design is dependent on available resources (equipment and personnel), patient workload, physical layout and location of system components, and proximity of team members. The CT-simulation process can be grouped into three major categories:

TABLE III. Test specifications for image performance evaluation.^a

Performance parameter	Frequency	Tolerance limits
CT number accuracy	Daily—CT number for water Monthly—4 to 5 different materials Annually—Electron density phantom	For water, 0 ± 5 HU
Image noise	Daily	Manufacturer specifications
In plane spatial integrity	Daily—x or y direction Monthly—both directions	± 1 mm
Field uniformity	Monthly—most commonly used kVp Annually—other used kVp settings	within ± 5 HU
Electron density to CT number conversion	Annually—or after scanner calibration	Consistent with commissioning results and test phantom manufacturer specifications
Spatial resolution	Annually	Manufacturer specifications
Contrast resolution	Annually	Manufacturer specifications

^aDepending on the goals and prior clinical experience of a particular CT-simulation program, these tests, frequencies, and tolerances may be modified by the medical physicist.

1. CT-scan, patient positioning and immobilization

The CT-simulation scan is, in many respects, similar to conventional diagnostic scans. The primary differences are the requirements for patient positioning and immobilization, treatment specific scan protocols, often increased scan limits, use of contrast, placement of localization marks on the patient skin, and some other special considerations. These are discussed in Sec. V.

2. Treatment planning and CT-simulation

Beam placement and treatment design is performed using virtual simulation software. The simulation typically consists of contouring of the target and normal structures, placement of the treatment isocenter and the beams, design of treatment portal shapes, generation of DRRs^{2,11} and documentation. Methods for simulating specific treatment sites have been described by several authors.^{1,2,4,12,17-19}

Contouring: The treatment planning portion of the CT-simulation process begins with target and normal structure

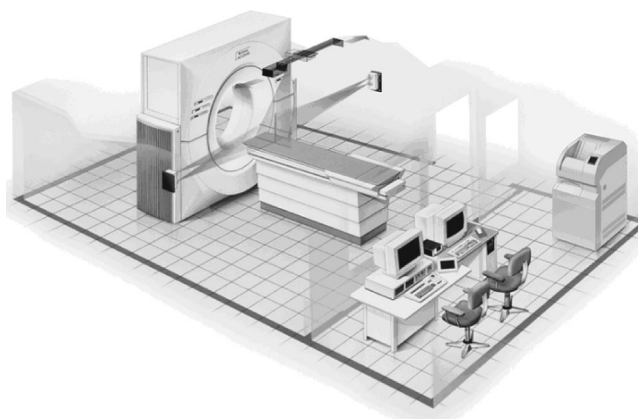

FIG. 2. CT-simulator room drawing showing wall lasers and the overhead sagittal laser. (Courtesy Philips Medical Systems).

delineation. Other imaging studies (prior CT, MR, PET) may be registered (fused) to the CT-scan to provide information for improved target or normal structure delineation.

Treatment isocenter placement: Based on target volumes and treatment area, a treatment isocenter location is identified in the CT study. The isocenter may be placed manually, based on patient anatomy, or the CT-simulation software may automatically position the isocenter at the centroid of the contoured target volume. Once the isocenter is determined or “marked,” this coordinate becomes part of the treatment plan and may be used as a reference location in subsequent dose calculations. There must be a set of localization marks on the patient’s skin so that the patient can be accurately repositioned on the treatment machine. The placement of localization marks may be performed using two different CT-simulation methods.

Final isocenter (setup-point) marked during the CT-scan: for this method, the patient is scanned and, while the patient is still on the CT-scanner couch, the physician with possible dosimetrist/medical physicist assistance determines the location of the isocenter. The software’s previously mentioned ability to define the centroid of the contoured target volume can be used for this task. During this time, the patient must remain still on the CT couch in treatment position. The isocenter coordinates are then transferred to the scanner and localization marks are accordingly placed on the patient. On the first day of treatment, the patient will be positioned using these marks on the treatment machine.

This method requires that the physician be available during the CT-scan, and the procedure time is longer. However, the marks made for the CT-scan can be used for positioning on the treatment machine without any shifts.

A reference point marked during the CT-scan: this method does not require the radiation oncologist to be available for the CT-scan. Prior to the scan procedure, based on the diagnostic workup studies, the physician instructs the CT-scanner staff where to place a set of reference marks on the patient. For example, “place localization marks at the level of carina, 4 cm left from patient midline, and midplane.” The intent is to place these initial marks as close to the final treatment isocenter as possible. Prior to the CT-scan, the reference marks are marked on the patient and radio opaque markers are placed over the skin marks. The radio opaque markers allow the reference marks to be visible on the CT study. After the scan, the patient can leave and images are transferred to the virtual simulation workstation. Later, the physician contours target volumes and determines the treatment isocenter coordinates. Shifts (distances in three directions) between the initial reference marks and the final treatment isocenter are then calculated. On the first day of treatment, or on conventional simulator if also available, the patient is first aligned to the initial reference marks using the treatment machine’s lasers and then *shifted* to the CT-simulation isocenter using the calculated shifts. Initial reference marks are then removed and the isocenter localization marks are placed on the patient.

This method is commonly used when the CT-scanner is not located in the radiation oncology department or when the

radiation oncologist is not available for the CT-scan. With proper planning (from diagnostic workup), the initial marks can be placed very close to the center of target volume and thus avoiding the need for shifts for the majority of patients.

Alternatively, for certain treatment sites, the localization marks are placed on a stable anatomical location which will reduce daily setup variations. The second method can be used for stimulation of these treatment sites. The setup marks are placed on a stable anatomical location and then shifts are applied to the treatment isocenter for every treatment. For example, patients with breast cancer can have setup marks placed on sternum rather than on breast tissue.

Placement of the beams and design of treatment portals: Based on target geometry, treatment beams are placed and treatment portals designed. CT-simulation data (images, contours, treatment beams) are then communicated to treatment planning software, which has dose calculation capabilities.

Printing of DRRs and documentation: The final products of the CT-simulation are DRRs and patient setup instructions. Patient setup instructions may include possible shifts from the initial skin localization marks, if final isocenter marking procedures were not used.

3. Treatment setup

On the treatment machine, the patient is setup according to instructions created from the CT-simulation software. Port films are acquired and compared with CT-simulation DRRs. In some cases, the patient may undergo treatment setup verification on a conventional simulator prior to the treatment. This can be valuable for treatment sites in the thorax and abdomen, for example, due to the CT-simulation process’ inability to display breathing motion. In such cases, the physician may wish to observe patient breathing on a conventional simulator using fluoroscopic imaging, with treatment blocks in place.

A well-designed CT-simulation process can cause all of these steps to appear relatively seamless, and the duration of the entire process relatively short. Conversely, inadequately defined procedures and a lack of communication can lead to inefficiencies and treatment errors.

B. Quality assurance program goals

The goals of a CT-simulation QA program are to assure safe and accurate operation of the CT-simulation process as a whole. The QA program design should include tests which will assure accurate target and critical structure localization and accurate placement of treatment beams with respect to a volumetric CT-scan of a patient.

1. Safety of patients, public, and hospital staff

While CT-scanners are generally regarded as “safe” medical devices they are radiation producing equipment and

as such capable of harming patients, staff, and public. The QA program must assure that radiation levels from the CT-scanner are safe, and that they comply with applicable regulatory limits.

2. Accurate target localization and treatment simulation

For accurate patient treatment planning, the CT-scanner must provide high quality images, with geometrical and spatial integrity, and with a known CT number (Hounsfield unit)²⁰ to electron density relationship. The CT-scanner QA program should include tests to verify that all three of the above conditions are met. The primary areas of focus for the CT-simulation QA program should be the imaging performance and geometric accuracy of the CT-scanner, the geometric accuracy and utility of the CT-simulation software, accuracy and image quality of DRRs, and accuracy and integrity of information transfer between the various treatment planning and treatment delivery systems. The tests outlined in Secs. II, III, and IV are designed to detect potential errors that can affect accuracy of target and normal structure delineation and treatment simulation. The suggested frequency of these tests should ensure that critical problems are detected in a timely fashion. The tolerance limits for QA tests recommended in this report were designed to satisfy accuracy requirements of conformal radiation therapy. They are in accordance with AAPM Report No. 39, TG53, and NCRP Report No. 99⁴⁵ recommendations and have been shown to be achievable in a routine clinical setting. Depending on the goals and prior clinical experience of a particular CT-simulation program, these tests, frequencies, and tolerances may be modified by the medical physicist. Radiation therapy procedures which require higher precision (i.e., intensity modulated radiation therapy) may demand more stringent tolerance limits and testing frequency. Likewise, QA of CT-scanners which are primarily used for less demanding procedures can be based on less stringent limits. The modified QA program should still ensure that the QA goals and objectives outlined in this report are satisfied and that the quality of patient care is not compromised.

II. FUNCTIONAL PERFORMANCE CHARACTERISTICS OF CT EQUIPMENT

A. Overview of a CT-scanner and a virtual simulation system

A typical CT-scanner consists of an x-ray source, detector array, patient support table, and computer workstation. The x-ray source and the detector electronics are housed in a donut shaped gantry through which the patient's body is imaged transaxially while lying on the table. The coordination of the x-ray generation, table positioning, data acquisition and processing, and the display of the images are all under the control of a suite of inter-connected computers. The following is a discussion of major CT-scanner components, which are especially important in the CT-simulation process:

1. X-ray tube

Due to two predominate characteristics of the CT-simulation process, the x-ray tube must be designed to withstand high heat input and have rapid heat dissipation.

(a) *Large number of images per study:* CT studies for image based radiation treatment planning and CT-simulation usually involve larger number of images per patient than in diagnostic radiology. As will be discussed later, DRR quality is dependent on CT slice thickness; therefore, slice thicknesses of 3 mm to 5 mm are typically used with a possibility of using even smaller thicknesses with multislice scanners. Small slice thickness is also desired to delineate accurate treatment volumes and critical structures. Depending on the treatment site and the length of the scanned volume, typically 80 to over 200 images per patient are acquired.

(b) *Rapid study acquisition time:* Generally, CT-simulation studies are imaged in a single rapid acquisition. Rapid scan time minimizes motion artifacts (due to breathing or patient movement).

The x-ray tube must have large heat anode loading and heat dissipation capabilities to withstand the very high heat loads associated with the large number of images acquired in a rapid sequence. Heat anode storage is specified in millions of heat units (MHU). Anode cooling rate is specified in MHU per minute (MHU/min). CT-scanners should ideally have an x-ray tube capable of storing 5 MHU or more with 0.5 MHU/min or more cooling rate. Tubes with higher specifications are readily available from several manufacturers and will ease the simulation process. A review of CT tube characteristics was given by Fox.²¹

2. Collimator and attenuator

Under the x-ray tube, and in the path of the x-ray beam, filters and/or attenuators are used to harden the beam and to limit the dynamic range delivered to the detectors due to the range of thickness at the center and the periphery of the human body. A pre-patient x-ray beam collimator mounted under the x-ray tube port is used to produce a narrow beam of radiation, which is used to ensure one thin slice of the cross-sectional body anatomy is imaged at any given time.

3. Patient support table

The CT-simulation scanner table must have a flat top similar to radiation therapy treatment machines. Additionally, it should accommodate commercially available registration devices, Fig. 3. The registration device allows the patient immobilization device to be moved from the CT-scanner to a treatment machine in a reproducible manner, as will be discussed later.

Even though the general shape of the two tables may be similar, the treatment machine table usually has components ("tennis racket," removable panels, table support components, etc.) which are not reproduced on the simulator table. These differences can introduce setup errors due to different sag of two tables. Treatment polices and planning target volumes should account for these differences.

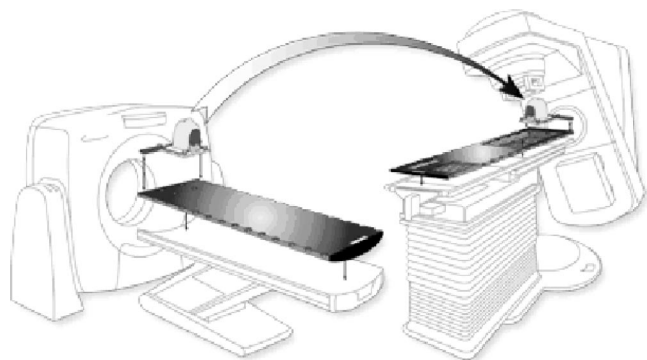

FIG. 3. Carbon-fiber CT-simulator couch top with registration device and use of a registration device. (Courtesy of MED-TEC, Inc, Orange City, IA).

The positioning and movement of the tabletop must be precisely controlled under constant load, this is discussed in Sec. III C 1. The couch weight limit (at least 400 lbs evenly distributed) and table sag should be comparable to those of medical linear accelerators.¹³

4. Computer and workstation

Computers are essential components of the CT-scanner. Transmission data collected by the CT detectors in its raw form bears no resemblance to the final cross-sectional image. The projection data must be processed or “reconstructed,” by the computer before a usable image can be displayed. Modern CT-scanners often consist of multiple dedicated microprocessors that are networked to communicate with each other to set up the scan parameters, and to coordinate the x-ray production and data acquisition. After the image data is reconstructed for viewing, a computer workstation also provides the means for the analysis of the image data. As discussed in the OVERVIEW section, to complete a CT-simulator unit, virtual simulation software is also required.

5. External patient marking/positioning lasers

Computed tomography scanners used for CT-simulation are usually equipped with external patient marking/positioning lasers. Figure 2 shows a set of such lasers. External lasers are not required for patient marking and lasers located inside the scanner gantry can be used for this procedure. However, these lasers can be difficult to use due to small aperture of scanner. Therefore, it is desirable that scanners which are used for CT-simulation be equipped with external lasers. These lasers can be fixed or mobile. Mobile lasers allow easier marking of patients. It is especially important that the sagittal laser be mobile as CT tables do not move in the lateral direction. Mobile sagittal laser allows marking away from the patient midline.

B. Conventional and spiral CT

Conventional CT acquires data one slice at a time. After all projections of a slice are acquired, the table is incremented and another slice is acquired. Alternatively, spiral (or helical) CT, which became available in the late 1980s, allows

data to be acquired while the table translates and the tube rotates continuously.²² The path of the tube forms a helical pattern around the patient, which is different from the set of “stacked rings” acquired in so-called conventional CT. A comprehensive review of the spiral CT technology can be found by Kalender.²³

Modern CT-scanners are typically capable of acquiring images in both scan modes. Due to faster scan times spiral mode is often preferred for CT-simulation scanning. The CT-scanner QA program should address image quality tests of both scan modes. Kalender²⁴ has discussed the image quality differences between axial and spiral scanning.

C. Multislice scanners

A recent development in CT technology allows projection data from multiple slices to be acquired simultaneously.^{25–27} Such multi-slice scanners use multiple row of detectors in the z axis. Data from one or several of the detector rows can be combined for a given data channel.

The primary advantage of multislice scanners is the ability to acquire image studies faster than single slice scanners. For example, a 4-slice helical CT can provide equivalent image quality at 2 to 3 times the volume coverage speed of a single slice helical CT.²⁶ Due to the longer length of imaged volume per tube rotation (multiple slices acquired simultaneously), the tube heat loading for a particular patient volume is lower for multislice than for single-slice scanners. Faster acquisition times and decreased tube loading of multislice scanners (which will allow longer volumes to be scanned in a single acquisition) can potentially provide an advantage over single-slice systems for CT-simulation purposes. Multislice technology can be especially beneficial for simulation of the thorax where breathing artifacts can be minimized. This technology can also be valuable for simulation of respiratory-gated treatments.^{27–30} Multislice scanners are also capable of acquiring thinner slices which can result in better quality DRRs.

Image performance of multi slice scanners may be evaluated by the same methods as conventional CT-scanners³¹ and QA procedures discussed in this report may be used.

D. Large bore scanners

Conventional radiation therapy techniques often require patients to be in positions that can prevent them from entering the 70 cm bore opening found on the majority of CT-scanners. As an example, breast treatments where the ipsilateral arm is subtended at close to a 90° angle frequently have difficulty entering the 70 cm bore. Inability to simulate all patients in a comfortable treatment position due to restricted bore opening has often been cited as one of the weaknesses of the CT-simulation process.^{1,3,12,32} At least one manufacturer offers a CT-scanner with an 85 cm bore opening, designed specifically for radiation oncology purposes. The larger opening allows for greater flexibility in patient positioning and use of immobilization devices. The 85 cm bore scanner also has increased scan field of view (SFOV), 60 cm compared to 48 cm on most 70 cm bore units. Increased

SFOV allows for full visualization of larger patients and immobilization devices. This feature is important to fully assess patient external dimensions which are necessary for radiation treatment planning and monitor unit calculations. The large bore scanner image quality is generally comparable to 70 cm units, however, some degradation in high contrast resolution and image noise have been observed.³³

Image performance of large bore scanners may be evaluated by the same methods as conventional CT-scanners,³³ and QA procedures discussed in this report are also applicable.

E. CT performance parameters

Ever since the availability of the first commercial CT-scanner, nearly 25 years ago, the evaluation of CT performance has not changed significantly over time. The performance parameters being evaluated typically include the x-ray system calibration, collimator assessment, localization laser alignment, slice width and sensitivity profile, radiation exposure and dose, image uniformity and noise, spatial resolution, contrast resolution, CT number calibration and linearity, and artifact evaluation. For surgical and radiation therapy planning applications, the scanner's internal calibration accuracy for the orientation, dimension, and position of the three-dimensional object being imaged must also be verified. Detailed discussions on the performance evaluation for acceptance testing and QA have been published on conventional and spiral CT^{14,34-37} for multi-slice scanners,³¹ and for large-bore scanners.³³ With the increasing presence of networked electronic devices and PACS systems, network communication and file compatibility issues among various computer workstations are additional performance parameters that must be addressed.

III. QUALITY ASSURANCE FOR CT-SCANNERS USED FOR CT-SIMULATION AND ITS FREQUENCY

For a successful CT-simulation process, the CT-scanner should consistently produce patient images with the highest possible quality and accurate geometrical information. Image quality directly affects the physician's ability to define target volumes and critical structures, and the spatial integrity of the CT study establishes how accurately radiation can be delivered to target volumes. The CT-scanner evaluation process consists of an evaluation of patient dose from the CT-scanner, radiation safety, electromechanical components, and image quality. Testing procedures and QA devices described here are just for illustration purposes. They are intended to describe a general approach to CT-simulation QA. Alternative testing methods and phantoms exist and can certainly be used in place of methods described here.

A. CT dosimetry

A primary concern of CT-simulation QA is patient safety. Radiation doses received by radiation therapy patients from a CT-simulation scan are insignificant in comparison with treatment dose from primary radiation fields and scatter and leakage radiation³⁸ and scan doses are in general not a seri-

ous concern. However, CT-scanner dosimetry must be a part of initial acceptance testing and periodic scanner QA. CT-scanner dosimetry evaluation has been defined by a number of regulatory agencies, and can be a concern of the Joint Commission on Accreditation of Healthcare Organizations (JCAHO). A more detailed description of CT dosimetry is provided in the Appendix B. Recommendations for evaluation of CT dosimetry are provided in Table I.

B. Radiation/patient safety

Radiation exposure from CT-simulation procedures to hospital employees and the public must be below regulatory limits.³⁹ Part of the initial acceptance testing must include a shielding survey. Appendix C includes discussion on radiation safety survey and shielding evaluation.

As with other radiation producing devices, CT-scanners are equipped with emergency off switches. CT-scanner emergency off switches are usually located on the gantry and at the control console. The use of emergency off switches can damage the CT-scanner. These switches should be tested under conditions which will not harm the scanner.

CT-scanners are typically equipped with connections for door interlocks. The use of door interlocks for CT-simulator can potentially be harmful for the patient. If the scan is interrupted during image acquisition, the entire scan may have to be repeated. This would expose the patient to unnecessary radiation. A more troublesome situation would be interruption of a scan while the patient is being injected with a contrast material. Exposure to a person accidentally entering a CT-scanner room during image acquisition is minimal and well below regulatory limits. The interruption of a scan acquisition therefore has a potential to be much more harmful to the patient than beneficial for a person entering the scanner room. Therefore, door interlocks should be avoided in CT-simulator installations, unless required by other regulations. This recommendation is consistent with the International Electromechanical Commission Publication No. 60601-2-44 Amendment 1 (Medical Electrical Equipment. Part 2-44: Particular requirements for the safety of x-ray equipment for computed tomography) conclusions.

C. Performance of electromechanical components

Proper operation of electromechanical components can affect patient safety and the accuracy of CT-simulation process. This portion of the document describes testing of these components.

1. Patient marking/positioning lasers

As previously described, scanners used for CT-simulation are typically equipped with external lasers. These lasers are used to position the patient in the treatment position assuring that patients are straight and properly rotated. These lasers are also used to place positioning marks on patient skin.

Just as the treatment room lasers possess a well-defined and precise spatial relationship to the treatment machine isocenter, the CT-simulation patient marking lasers must pos-

sess a similar relationship to the CT-scanner image center. Thus, the accuracy of the lasers directly affects the ability to localize treatment volumes relative to patient skin marks and the reproducibility of patient positioning from the CT-scanner to the treatment machine. Accuracy and spatial orientation of lasers therefore must be comparable to treatment machine laser accuracy.¹³ Laser accuracy tolerances depend on the goals of radiation therapy and required accuracy of treatment procedures. Tolerances recommended in Table II need to be evaluated by individual institutions.

QA goals: CT-scanner patient marking/positioning lasers consist of three separate components: gantry lasers, wall mounted lasers (which may be mobile), and an overhead mobile sagittal laser (Fig. 2). The gantry lasers are typically mounted on a rotating frame within the gantry. The overhead gantry laser defines the sagittal and axial planes, while the two lateral gantry lasers identify the coronal and axial planes. In addition to the gantry lasers, two lateral, or side, lasers are mounted to the walls or rigid stands and project lines defining the coronal and axial planes (horizontal and vertical, respectively). The vertical wall lasers are mounted to project at a predefined, fixed distance (usually 500 mm) away from the imaging plane. Last, an overhead laser projects a laser line defining the sagittal plane. During the CT-simulation process the wall and overhead lasers are used for patient marking.^{1,2,4,12}

The following are performance requirements for CT-scanner lasers:

- (1) gantry lasers should accurately identify scan plane within the gantry opening;
- (2) gantry lasers should be parallel and orthogonal with the scan plane and should intersect in the center of scan plane;
- (3) vertical side-wall lasers should be accurately spaced from imaging plane;
- (4) wall lasers should be parallel and orthogonal with the scan plane, and should intersect at a point which is coincident with the center of the scan plane;
- (5) the overhead (sagittal) laser should be orthogonal to the imaging plane;
- (6) the overhead (sagittal) laser movement should be accurate, linear, and reproducible.

Tools needed: An alignment tool or a phantom is needed to assess laser geometry and accuracy. There are several designs for scanner laser QA devices. Figure 4 shows an example of such a device. This QA device can be used to assess all of the above six performance requirements for scanner lasers. In addition, other geometric and imaging tests can be performed with the device. The device used here is just for illustration purposes and its use is described for testing of other parameters throughout this document. Devices with similar functionality are commercially available and can also be used for these tests. In absence of such devices, the medical physicist can devise procedures that test same parameters or use alternative testing methods.

Test method: A sample laser QA process, step-by-step pro-

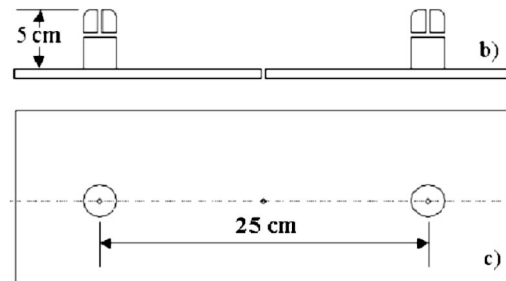
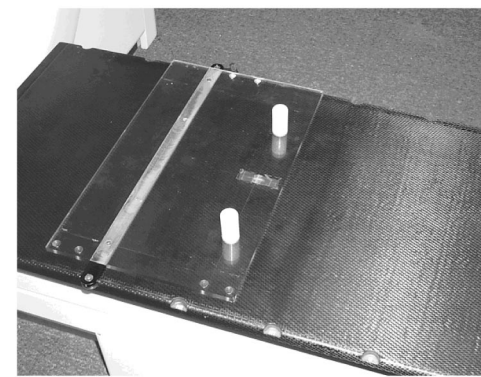

Fig. 4. (a) CT-simulator laser QA device attached to the table top using a registration bar; (b) diagram of the side view of the device through the center of two pegs showing holes drilled inside the pegs; (c) diagram of the top view of the device.

cedure, and accompanying form are included in the Appendix D. Parts of this process should be performed daily, as suggested in Table II, and the full procedure should be performed monthly or more frequently depending on laser stability.

2. Couch and tabletop

Diagnostic CT-scanners are usually equipped with only a cradle-shaped couch top (the tabletop is cup shaped to conform to the circular opening of the CT-scanner gantry). Scanners used for CT-simulation require a flat tabletop similar to the treatment machine's tabletop geometry. The flat tabletop can be an insert that fits inside the cradle of the existing table or an overlay which is mounted on the top of the cradle (Fig. 3).

Relative to treatment setup accuracy, the tabletop represents a direct connection between the CT-scanner and the treatment machine. Inaccuracies in the scanner tabletop geometry will translate into poor patient position reproducibility on the treatment machine. Additionally, inaccurate table indexing can cause image spatial distortions,³⁶ and vertical and longitudinal movement errors can cause inaccuracies in marking of the patient's skin relative to the calculated treatment isocenter.

QA goals: The following are performance requirements for the CT-scanner couch and tabletop:

- (1) flat tabletop should be level and orthogonal with respect to the imaging plane;

- (2) table vertical and longitudinal motion according to digital indicators should be accurate and reproducible;
- (3) table indexing and position under scanner control should be accurate;
- (4) flat tabletop should not contain any objectionable artifact producing objects (screws, etc.).

Test method: A sample QA procedure for scanner table and rationale for the above listed tests are provided in the Appendix E. Testing frequencies and tolerances are specified in Table II.

3. Gantry tilt

The majority of CT-scanners are capable of acquiring nonorthogonal CT-scans by tilting the gantry. This feature is useful for acquiring diagnostic images through certain anatomical structures which are not necessarily parallel with the imaging plane. Scanner tilt is generally not desired in CT-simulation. However, as the majority of scanners are capable of gantry tilt this issue must be addressed in the CT-simulation QA program.

QA goals: The digitally indicated angle of the CT-scanner gantry with respect to the nominal vertical imaging plane, should be accurate within $\pm 1^\circ$. For scanner used for CT-simulation, it is most important that the gantry accurately returns to the nominal vertical scan plane after being tilted to some other angle. This is especially relevant for scanners that are being shared with diagnostic radiology. A dedicated scanner may only rarely have its gantry tilted away from the vertical scan plane. However, a shared scanner may frequently have its gantry tilted for, nonorthogonal, diagnostic scans. As described in Sec. III C 2, the scanner gantry must be level/orthogonal with respect to the couch tabletop. The following are requirements for scanner gantry tilt:

- (1) the angle of gantry tilt with respect to the nominal vertical imaging plane should be accurate;
- (2) after the tilt, the gantry should return to the nominal vertical imaging plane (i.e., orthogonal to the tabletop).

Tools needed: Ready-pack film, laser QA device from Fig. 4, square acrylic or water equivalent plastic sheet from 2 to 4 cm thick.

Test method: (1) *The angle of gantry tilt with respect to the nominal vertical imaging plane should be accurate.* This test has been described in detail in Report No. 39 (III A 3)¹⁴ and by McCollough.³⁶ A ready-pack film is taped to a square acrylic or water-equivalent plastic sheet. The sheet is placed on its side aligned with the sagittal gantry lasers (orthogonal to the imaging plane). The side gantry lasers should intersect in the approximate vertical center of the film. A single scan with the thinnest available thickness is first acquired with gantry at 0° . The gantry is then tilted in both directions (towards and away from the table) and a single scan is acquired at both gantry positions. For both gantry angles, the gantry position should be close to the end of the range of motion. The angles between the vertical (nominal gantry position) exposure and tilted gantry exposures as measured

with a protractor on the film should agree within $\pm 1^\circ$ of the digitally indicated gantry angle used for exposure.

(2) *After tilt the gantry, the gantry should return to the nominal vertical imaging plane (i.e., orthogonal to the tabletop).* This test is performed by aligning the laser QA device with the gantry lasers and assuring that the device is aligned with the side vertical gantry lasers through the full range of the vertical couch travel. The gantry is then tilted in either direction and then returned to the vertical position. The alignment of the laser QA device with vertical side gantry lasers should remain within 1 mm from the side holes on both pegs. The test should be repeated for tilting the gantry in the opposite direction and returning it to the nominal position.

4. Scan localization from scout image (topogram, pilot image)

Accurate scan volume and scan location as prescribed from the scout image (topogram, pilot image) is important for accurate clinical scanning. This feature can be especially important when performing quantitative measurements or scans of phantoms and dosimetric equipment.

QA goals: The scan volume and scan location as prescribed from the scout image should be accurate within 1 mm. Evaluation of the radiation profile width and sensitivity profile width has been described in detail in Report No. 39 (III A 4) and by McCollough.^{35,36}

5. Collimation

The majority of CT-scanners collimate the radiation beam in the longitudinal direction distal to the x-ray source (pre-patient collimation) and also immediately prior to the detector array (post-patient collimation). The accuracy of both, the pre- and post-patient collimation can significantly influence the scan image quality. Additionally, the pre-patient collimation has direct influence on patient dose from a CT-scan. The accuracy of the pre-patient collimation is evaluated by measuring the *Radiation Profile Width* emerging from the scanner.^{14,31,36,40-42} The actual width of the imaged slice, which is affected by the post-patient collimation, is assessed by measuring the *Sensitivity Profile Width*.^{14,35,36,39,43} If the radiation profile width is wider than indicated, unnecessary radiation will be delivered to the patient, thus increasing the total dose from the scan. An excessively narrow radiation profile or sensitivity profile width may cause increased quantum noise due to reduced photon count. Excessive sensitivity profile width can result in some loss of resolution in the longitudinal direction.

Evaluation of the radiation profile width and sensitivity profile width has been described in detail in Report No. 39 [III A 6(a) and III A 6(b), respectively] and those procedures are recommended by this report. Manufacturer supplied performance evaluation phantoms and software routinely have the capability to evaluate sensitivity profile width. This utility should be included in the periodic QA program. During the scanner commissioning process, the manufacturer-supplied performance evaluation phantoms and software

must be validated independently.^{31,33} The manufacturer sensitivity profile width test can be validated by comparison with the test performed according to the Report No. 39 procedure.

6. X-ray generator

Similar to other radiographic equipment, proper operation of a CT-scanner requires that quantity and quality of photons emitted from the x-ray tube agree with settings programmed on the control console for scan acquisition. Miscalibration or performance errors of the x-ray generator components can result in poor images with readily visible artifacts. The scanner software itself is often capable of detecting such errors and aborting scanning. The tests outlined in the Appendix F should be performed during commissioning and then annually if desired.

D. Image quality tests

Image quality directly affects the ability to identify and delineate target volumes and surrounding critical structures for radiation treatment planning. Suboptimal image quality may cause the omission of a portion of the target volume or inadvertent delineation of normal structures as target volumes, therefore, causing serious errors. It is imperative that the image performance of a CT-scanner used for CT-simulation be maintained as optimally as possible. The scanner QA program should be structured to detect quickly and identify degradation in imaging performance. Optimal image performance for the purposes of the QA program means that the CT-scanner at least meets or exceeds minimal manufacturer specifications. The QA program goals should be to verify that the scanner meets manufacturer specifications. Due to significant differences in design and imaging capabilities of modern CT-scanners, common minimum standards for image performance indicators for all scanners are not practical. The AAPM Report No. 39 addresses in detail image performance tests. Tests and recommendations outlined in that report are sufficient for establishment of image performance QA for scanners used for CT-simulation. Furthermore, the majority of scanner manufacturers have phantoms and software, which are supplied with the CT-scanner, which can be used to assess image quality as a part of a QA program. Although, the primary purpose of these vendor supplied phantoms is for scanner calibration and automated baseline performance evaluation it is reasonable to assume that they can be used for periodic scanner performance evaluation. The validity of CT-scanner manufacturer supplied phantoms and software must be verified against independent test methods or phantoms before they can be used for routine QA. During the initial acceptance testing and commissioning, tests should be performed with both, manufacturer phantom and independent test methods.³³ Portions of this validation should be repeated during the annual scanner QA. Commercial CT performance phantoms are well suited for independent verification of manufacturer supplied phantoms and performance evaluation software. Image quality tests outlined below are in order as they are presented in Report No. 39.

1. Random uncertainty in pixel value (noise)

Ideally, a CT-scan of a uniform phantom would have uniform pixel values (CT numbers) throughout the phantom image. In reality, the CT numbers in an image of a homogenous phantom are not uniform. The variation in pixel intensities has random and systematic components. The random component of image nonuniformity is noise. The standard deviation of pixel values in a region of interest (ROI) within a uniform phantom is an indication of image noise. The noise can be expressed in terms of standard deviation of the CT numbers in Hounsfield units (HU) or as a percent of the linear attenuation coefficient of water (μ_w) and corrected for the scanner contrast scale:^{14,44}

$$\text{Noise} = \frac{\delta \cdot \text{CS} \cdot 100\%}{\mu_w}, \quad (1)$$

where δ is the standard deviation of CT numbers within the region of interest; CS is the contrast scale defined as $\text{CS} = (\mu_m - \mu_w / \text{CT}_m - \text{CT}_w)$, where μ_m and μ_w are the linear attenuation coefficients for the subject material and water, respectively, and CT_m and CT_w are the measured CT numbers for the subject material and water, respectively.

Image noise determines the lower limit of subject contrast that can be distinguished by the observer (physician, dosimetrist, etc.). The more uniform the background containing a low contrast object, the greater its contrast with that background. Theoretically, minimal noise images should increase normal structure and target delineation accuracy.

Noise is very a sensitive parameter to the overall imaging performance of the scanner, and can usually be performed in conjunction with uniformity tests (next section). We recommend that noise be evaluated daily.

QA goals: The QA program should verify that the scanner noise meets or exceeds manufacturer specifications. Scanner noise should be evaluated daily as outlined in Table III.

Tools needed: Head and body water phantoms (manufacturer provided phantoms are adequate for this purpose) or commercially available phantoms.

Test method: Noise measurements should be performed as outlined in Report No. 39 (III B 1). Alternatively, the manufacturer performance phantom and software may be used to measure noise.

2. Systematic uncertainty—field uniformity

Image artifacts due to equipment design, beam-hardening, or image reconstruction software can manifest themselves as systematic CT number (HU) variations. Scanning a uniform phantom and sampling mean HU values for ROIs of fixed areas throughout the phantom can quantify the presence of systematic variations. This process is referred to as a field uniformity test. Report No. 39 (III B 2) provides a detailed discussion of various causes of field non-uniformity, and measurement procedures. As described below, a water scan which is used to verify CT number accuracy and field uni-

formity should be acquired monthly for the most commonly used kVp and annually for other kVp settings with tolerance of ± 5 HU.

QA goals: CT images should be free of systematic artifacts, and an image of a uniform phantom should have uniform appearance without streaking and artifacts. The difference in the mean HU values for ROIs sampled throughout a uniform phantom should be within 10 HU. Due to the simplicity of this test and its ability to reveal major system malfunctions, field uniformity tests should be performed daily for the most frequently used scan kVp and monthly for other kVp values.

Tools needed: Typically, a body and a head phantom are used (32 cm and 16 cm diameter water-filled cylinders). The manufacturer-supplied phantom should contain both of these sections.

Test method: Field uniformity measurements should be performed as outlined in Report No. 39 (III B 2). Alternatively, the manufacturer performance phantom and software can be used to perform this test.

Both the procedure described in Report No. 39 and manufacturer test procedures require the uniformity phantom to be centered in the scan plane. This is indeed appropriate for diagnostic CT-scanners, as the vast majority of patients are placed in that location for clinical scanning. CT-simulation scans frequently require the anatomical area of interest to be placed away from the center of the scan field. For example, breast patients are typically placed to the side of the scan field to allow the ipsilateral arm to pass through the scanner opening.¹⁹ Therefore, field uniformity for the scanner used for CT-simulation should be evaluated with the phantom placed in the center of scan field and also with the phantom displaced towards the edge of the field. For daily tests, the phantom should be centered. For monthly tests, the phantom can be shifted. The manufacturer stated uniformity specifications only apply to centered phantoms. When the phantom is shifted, it may not be possible to maintain manufacturer uniformity specifications. Therefore, the baseline values measured at the time of scanner installation should be used for uniformity evaluation with the shifted phantom. The evaluated area should be meaningful with respect to the size of the scan field.

Image artifacts visible on patient images may not always be visible on phantom images. A scanner image reconstruction algorithm is designed to compensate for certain image artifacts. Often, this software does a very good job for phantom images as these are used in the software development. The software may not perform as well when scanning certain body areas, and can actually introduce artifacts. Patient images should also be viewed for artifacts due to field non-uniformity.

3. Quantitative CT

Typically, images acquired by the scanner used for CT-simulation will be used for dose distribution calculations. The majority of modern treatment planning systems can perform density-corrected dose calculations. These calculations

typically rely on relative physical or electron density (number of electrons per unit volume) information contained in the CT images. This information is obtained from CT images using a density to CT number conversion. This relationship is typically scanner dependent. If multiple scanners and scan energies are used to provide treatment-planning images, density to CT number relationship for all scanners should be evaluated for consistency. Part of the periodic CT-simulation QA program should be an evaluation of CT number accuracy and density to CT number relationship.

Each CT image is a two-dimensional matrix of CT numbers corresponding to mean linear attenuation coefficients of the material in each voxel.²⁰ Scanner software has tools which will report the mean CT numbers for the region of interest in a CT image. The measured mean CT number for a given material should correspond to a value calculated based on the mean linear attenuation coefficient for the given material and water at specific beam energy. However, this relationship depends on scanner performance and calibration and should be verified experimentally.

When density-corrected dose calculations are used for treatment planning, incorrect CT number to density relationship can cause dose calculation errors. This was discussed in more detail by TG53.¹⁵

QA goals: The QA program should include verification of CT number accuracy (measured CT numbers should agree with their theoretical values). The National Council on Radiation Protection and Measurements (NCRP) Report No. 99⁴⁵ has discussed tolerances for CT number accuracy. In the absence of manufacturer specifications, NCRP report recommendations can be used as tolerance limits. CT number accuracy should be verified daily at least for water. Accuracy for three to five additional materials should be verified monthly and after scanner recalibration or major component replacement. The manufacturer phantom or electron density phantom can be used for this task.

Furthermore, the density to CT number conversion relationship should be determined during initial scanner commissioning and verified at least annually. Commercially available electron density phantoms can be used for this task. These phantoms often consist of a water-equivalent plastic disk approximating the size of an average pelvis with holes in the disk to hold interchangeable rods made of various tissue and water simulating materials. Since CT images can theoretically cover a 16-bit range of values, planning software should be checked for compatibility in handling very low negative and very high positive numbers. Some treatment planning systems have created calculation errors when such numbers were associated with the treatment planning study set.

Test method: This procedure is performed with a density phantom and is similar to the test for evaluation of field uniformity. After scanning the uniform section of the manufacturer phantom, the ROI tool is used to measure the mean CT number for water. This value should be within an acceptable tolerance (usually $0 \text{ HU} \pm 5$). For monthly tests, this procedure is repeated with a phantom that contains multiple objects of known composition. The phantom is scanned and

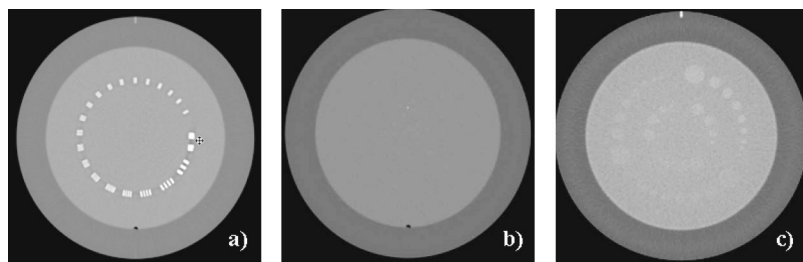

FIG. 5. Image performance evaluation phantom: (a) line-pair section, (b) MTF section, (c) low contrast resolution section.

the ROI tool is used to evaluate the mean CT number for each of the materials. The numbers should be consistent with theoretical and baseline values, measured at the time of commissioning.

For density to CT number conversion measurements, a phantom with several objects of known composition is needed. The ROI tool is again used to measure the mean CT number for each material. These numbers can be plotted and compared with commissioning data.

4. Spatial integrity

Radiation treatment planning relies on accurate reproduction of true patient dimensions and shape in CT images; this includes external skin contour and internal organs. Image distortions can potentially cause dosimetric errors by causing delivery of inappropriate radiation doses or treatment of the wrong area. Therefore, spatial integrity should be verified as a part of the CT-scanner QA program.

QA goals: CT-simulation images should accurately reproduce true patient anatomy within ± 1 mm without spatial distortions in the entire scan field. This should be verified for both head and body scan protocols using a phantom of known dimensions.

5. Spatial resolution

Spatial resolution is a common parameter used for evaluation of imaging systems. It characterizes the imaging system's ability to distinguish between two very small objects placed closely together. Spatial resolution measurements are performed with objects which have a high contrast (contrast difference of 12% or greater) from uniform background.²⁰ Spatial resolution is frequently referred to as *high contrast resolution*. High contrast resolution is a function of blurring present in a CT image.^{14,20} High contrast resolution is most commonly measured using either a resolution pattern (line pair phantom with a range of spatial frequencies), or by the modulation transfer function (MTF) method. Physical properties, measurement techniques and evaluation of resolution pattern and MTF have been described in detail in the literature.^{14,31,33,35,46-52} CT image of a line pair phantom is shown in Fig. 5(a). The line pair pattern in Fig. 5(a) ranges in frequency from 1 lp/cm to 21 lp/cm. Fig. 5(b) shows a CT image of a phantom which contains a high-density, tungsten carbide bead which is used to create an impulse, or point source, from which the MTF can be calculated. Manufacturers often specify the limiting spatial resolution at the 5% or lower point on the MTF curve. The limiting spatial resolu-

tion (lp/cm) measured with MTF, and specified at the 5% value, is typically higher than the resolution that can be observed with a line pair phantom. Therefore, spatial resolution measured with a line pair phantom may not always meet manufacturer specifications. To verify the manufacturer's specification, the scanner MTF should be measured. The manufacturer supplied performance phantom and software should be capable of measuring MTF. Spatial resolution measured with the manufacturer phantom should be independently verified as described in Report No. 39 [III B 3(a)]. At the same time a baseline measurement with a line pair phantom may be obtained, which can then be used as a reference for periodic QA measurements.^{33,53}

Spatial resolution is a fundamental indicator of the scanner's imaging capabilities. The CT-scanners used for CT-simulation should be able to image and differentiate small details in patient anatomy, as well as any implanted objects. For example, CT-scanners are often used to image post-brachytherapy-implant prostate patients and image resolution should be capable of distinguishing seeds located closely together.⁵⁴

QA goals: The scanner should meet manufacturer specified spatial resolution performance. The spatial resolution should be evaluated monthly (Table III).

Tools: Manufacturer phantom, line pair phantom, or a commercial CT performance phantom.

Test method: As outlined in the AAPM Report No. 39.

6. Contrast resolution

Contrast resolution can be defined as the CT-scanner's ability to distinguish relatively large objects which differ only slightly in density from background.²⁰ Contrast resolution is often referred to as *low contrast resolution*. Low contrast resolution is typically evaluated with a phantom that contains low contrast objects of varying sizes.^{14,20,31,33-36} Also multiple sets of objects of different contrasts can be contained in the phantom. The phantom imaged in Fig. 5(c) contains three sets of cylindrical rods of various diameters and contrast levels to measure low contrast performance. The rod diameters at each contrast level are 2, 3, 4, 5, 6, 7, 8, 9, 10, and 15 with nominal contrast levels of 0.3%, 0.5%, and 1%.

QA goals: Quality assurance should demonstrate that the CT-scanner meets or exceeds manufacturer specifications for low contrast resolution. This can be evaluated using a commercially available, low contrast phantom. The manufactur-

er's performance phantom and software may also be used for this task, providing that its measurements are independently verified.

Tools: Commercial low contrast phantom or manufacturer performance phantom.

Test method: As outlined in the AAPM Report No. 39 [III B 3(b)].

IV. QUALITY ASSURANCE FOR CT-SIMULATION SOFTWARE AND ITS FREQUENCY

CT-simulation is a geometric simulation process that provides beam arrangements and treatment fields without any dosimetric information. For this process to be successful, accurate beam geometry information should be maintained in the software and accurate patient geometry should be supplied. Since the core of CT-simulation is the processing of patient images in the virtual simulation software, the accuracy and integrity of that software should be a prime consideration. The CT-simulation software accuracy should be verified during alpha and beta testing by the manufacturer; however, when it is released, it should be tested clinically by the therapy physicist. A list of test parameters was published by McGee and Das.⁵⁵ The AAPM TG53 report¹⁵ also addresses in detail commissioning, acceptance testing, and periodic QA of clinical radiation treatment planning systems. Chapter 3 of that report discusses testing of nondosimetric aspects of treatment planning features. The majority of these tests are related to CT-simulation software. The current task group fully endorses the recommendations of the AAPM TG53 for QA of treatment planning systems and we recommend that procedures outlined in that report be implemented as a part of the CT-simulation QA program. Therefore, we list here only a partial list of CT-simulation software function tests and refer the reader to the TG53 report for detailed descriptions.

Quality assurance of CT-simulation software can be simplified with the use of appropriate phantoms. These phantoms allow evaluation of imaging and geometric accuracy of CT-simulation software. Craig *et al.*⁵⁶ and McGee *et al.*⁵³ have described such phantoms. One such phantom is shown in Fig. 6. The QA program should include verification of the following CT-simulation software features:

A. Spatial/geometry accuracy tests

1. Image input test

These tests should verify that images transferred from the CT-simulation scanner or other scanners (CT, MRI, PET) have correct image geometry (e.g., pixel size, spatial fidelity, slice thickness and spacing), image orientation (e.g., prone/supine, head-foot orientation, and left–right orientation), scan text information, and grayscale values. These objects are transferred on most modern systems using *Digital Image Communications in Medicine* (DICOM) standard.⁵⁷ DICOM is a standard for representing and exchanging medical imaging data. The image transfer test should include verification of proper transfer and processing of DICOM objects.

Correct image orientation is always a concern when images are transferred between treatment planning systems. This is especially true when images contain symmetric anatomy which does not indicate patients right or left side; or if there is a concern if the patient was scanned with head or feet towards the gantry. It is often desirable to have a landmark in the CT image that indicates patient geometry. Two thin aluminum wires can be taped on the bottom of the CT-scanner tabletop to indicate patient orientation in CT images. The wires should be taped on the left or right side of the tabletop and along its entire length. The two wires should also form the letter “V” which is pointing towards the gantry. The letter “V” indicates patient's scan orientation (Head/Feet first). The wires should be small enough to avoid image artifacts. The right side of image in Fig. 8(a) contains such wires.

2. Structure delineation

Tables 3-4 and 3-5 in the TG53 report list tests related to anatomical structures and contouring. Anatomical contours are one of the building blocks of conformal radiation therapy and errors associated with manipulation and processing of contours can cause potentially serious dosimetric errors.

3. Multimodality image registration

Treatment planning process is increasingly dependant on input from several imaging modalities. As previously discussed, MRI and PET have much to offer in identification of target volumes and other structures. Image registration is often part of CT-simulation process and proper operation of software and image transfer must be verified. Image registration can be a complicated process and TG53 recommends that AAPM form another task group specifically charged to develop a report on the use and QA of dataset registration techniques. Mutic *et al.*⁵⁸ have described a phantom and process for QA of image registration.

4. Machine definition

Another important CT-simulation software feature is the ability to create virtual treatment machines. The description, limits, and readouts of virtual machines have to correspond with actual treatment machines and must be machine type specific. Tables 3-9, 3-10, 3-11, 3-12, 3-13, and 3-14 in the TG53 report provide detailed lists of machine parameters and appropriate tests. Some of the tests listed in these tables are related to dose calculation and do not apply to CT-simulation. Machine definition also includes verification of the virtual machine's geometric resolution and accuracy. It is reasonable to expect that geometric accuracy of a virtual treatment machine is better than that of a real machine.

Collimator simulation: Collimator geometrical accuracy should be similar to a treatment machine. The field size accuracy provided by CT-scanner should be within ± 1 mm for the entire range of field sizes. This accuracy should also be the same for collimators with MLC. The CT-simulation software should provide the capability of independent jaws and various MLC design. The user should verify proper opera-

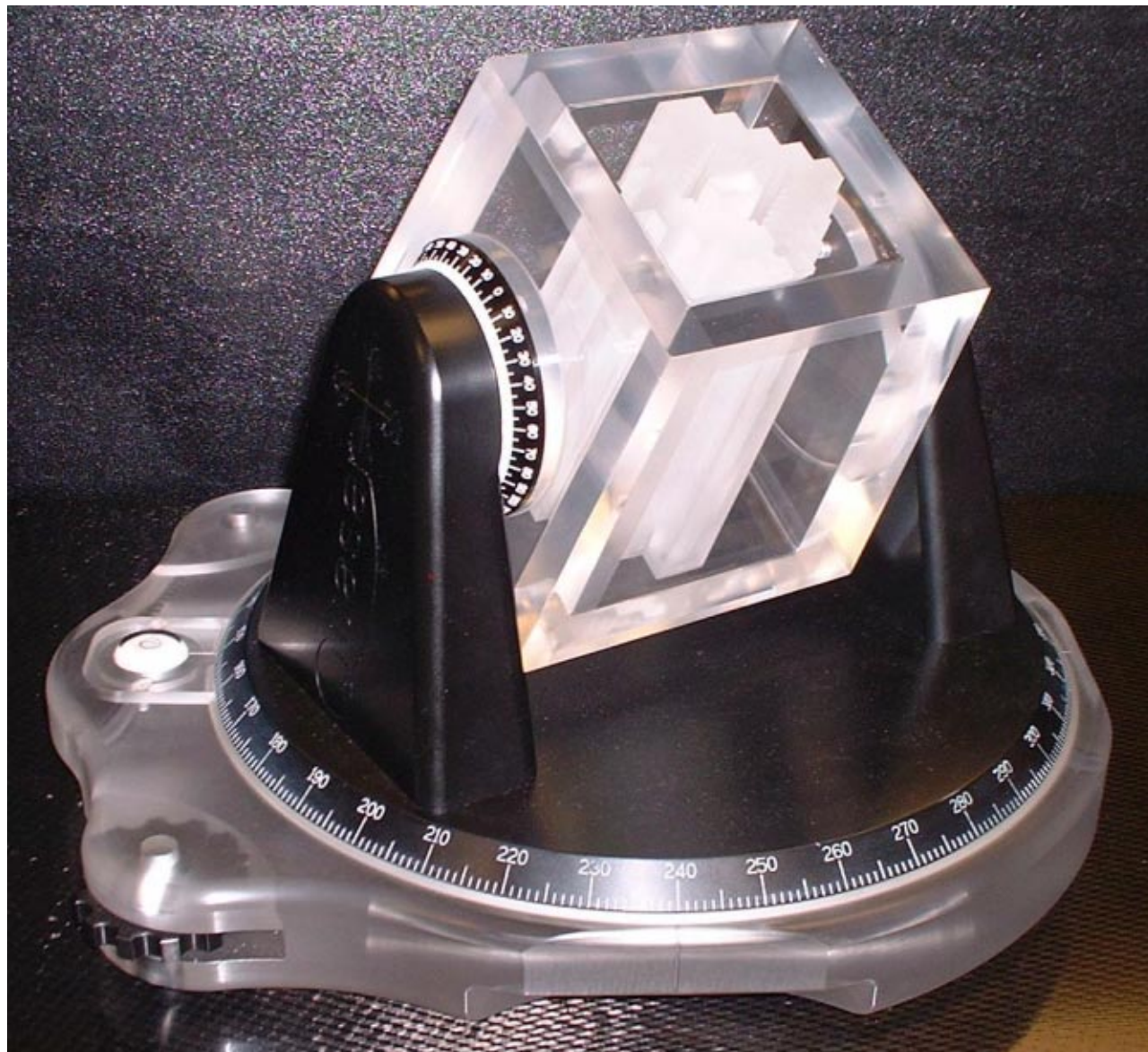

FIG. 6. A quality assurance phantom for three-dimensional radiation treatment planning.

tion, size, limits, and features of a virtual MLC and compare them with real MLC properties. Additional descriptions of various MLCs can be found in the literature.⁵⁹⁻⁶⁷

Collimator rotation should be within $\pm 1^\circ$ over full rotation (360°). Accuracy of jaw positions at various collimator angles should be tested. Comprehensive evaluation should be at a minimum interval of 45° .

Gantry rotation: Gantry rotation should be accurate to within $\pm 1^\circ$. Combined functionality of the gantry and collimator should be tested at multiple positions. A standard convention for specifying gantry angle, collimator angle, table angle, MLC orientation, and patient orientation is still desirable. As specified in the TG53 report, these conventions must agree between CT-simulation software and the treatment machine. Errors in machine configuration can cause significant difficulties in patient treatment. Virtual treatment machines can typically be assigned limits to motion, but in certain

situations, the simulation software may not be able to accept specific treatment machine configuration. This is primarily due to the fact that software vendors can not predict all possible combinations of orientations for treatment machines. In this situation, the treatment setup documentation created by the simulation software will not agree with the actual treatment parameters and this may be unavoidable. The CT-simulation QA program should include steps to verify that the printed documentation is properly corrected and that treatments are implemented correctly.

Patient support assembly (PSA) simulation: Virtual simulation should provide the PSA movement and rotation functionality. An advantage of CT-simulation is that it can simulate and provide DRRs at angles which are not possible to simulate with conventional simulators.⁶⁸ The PSA rotation should be accurate to within $\pm 1^\circ$, which is commonly recommended for conventional simulators. Once again geo-

metrical accuracy must be tested with the combination of collimator and gantry rotation.

5. Isocenter calculation and movement

A part of the patient CT-simulation scan is identification of the treatment isocenter and placing of the corresponding localization marks on the patient's skin. As described in the overview of the CT-simulation process, once the patient is scanned the physician contours target volumes and simulation software calculates the treatment isocenter coordinates based on those target volumes. The calculated or physician selected isocenter coordinates are then used to move the CT-scanner table and the overhead laser to mark the patient. The accuracy of the isocenter calculation and shift instructions must be verified. This should be performed with a variety of target shapes (e.g., sphere, cylinder).

Often, when abutting beams are used for patient treatment or when multiple treatment sites are treated, there are multiple treatment isocenters. The software then creates a set of instructions on how to shift from the initial isocenter to other locations. The accuracy of these instructions must be verified in all three directions.

This also applies when the treatment isocenter is not marked during the CT-scan but only a set of initial reference marks is placed on patient's skin. In this situation, during the virtual simulation the software will calculate shifts from the initial reference to the treatment isocenter. These shifts will be used to setup the patient on the treatment machine.

6. Image reconstruction

Multiplanar and 3D image reconstruction is another significant component of CT-simulation software. These views are used to aid and evaluate beam placement and block design. Simulation software uses data in native axial images to create reconstructions in arbitrary planes and various 3D views. Typically, multiple views are displayed simultaneously. The tests should verify that the software accurately reconstructs these displays and that beam and block projection on these views is accurate. The tests should include a set of various geometrical shapes (square, rectangle, circle, ellipse) of different dimensions. The accuracy in drawn contours at any point should be within ± 1 mm.

B. Evaluation of digitally reconstructed radiographs (DRRs)

One of the final products of a CT-simulation process is a set of DRRs which is used for the verification of patient positioning on the treatment machine. The quality and accuracy of these images affect the physician's ability to verify patient setup. Poor quality DRRs may not allow adequate verification of patient positioning due to the inability to visualize anatomical details and geometrically inaccurate DRRs will cause errors in patient setup and treatment due to positioning errors.

McGee *et al.*⁵³ described a phantom designed for this task. The phantom consists of a 15 cm³ polystyrene block with four test patterns to evaluate contrast resolution, spatial

resolution, ray line divergence accuracy, and spatial integrity. Phantom described by Craig *et al.*⁵⁶ can be used for geometric accuracy evaluation of DRRs.

1. Spatial and contrast resolution

It is generally understood that smaller slice thickness and spacing produces better spatial resolution DRRs. McGee *et al.*⁵³ reported that contrast resolution is affected by the image reconstruction area (field of view). Initial commissioning of CT-simulation software should include evaluation of DRR input parameters and possibilities for image quality improvement. It is difficult to specify tolerance limits for DRR spatial and contrast resolution. These are not routinely specified by the software manufacturer, references are scarce in literature, and image quality depends on many factors. Therefore, it may not be practical to initially determine if the system is operating correctly. A reasonable QA test would be to scan a phantom which is similar to that of McGee *et al.*⁵³ during the CT-scanner and simulation software commissioning and create baseline DRRs. The scan parameters and DRR settings should be recorded with the film. Upon replacement of major scanner components, DRR output device (film printer or plotter), and more importantly simulation software upgrades, this process can be repeated to verify image performance consistency.

2. Geometric and spatial accuracy

Systematic or random geometrical errors associated with DRR generation can easily translate into treatment errors. Small DRR magnification errors (2–5%), may result in systematic errors in block manufacturing which may cause systematic treatment of smaller or larger areas than intended. These errors can have dosimetric consequences, but due to small magnitude may not be detected by the physician. The majority of treatments distances are between 70 cm and 120 cm SSD, therefore, film magnification should be tested between these limits. Magnification should be within ± 1 mm of expected. Spatial errors (e.g., collimator, table rotation, incorrect jaw setting, etc.) can also cause errors which may not be detected from patient port films. The QA for the CT-simulation process should include evaluation of DRR geometric errors.

3. Hardcopy quality

Performance of the DRR output device should also be periodically evaluated. Printing of standard test patterns and comparison with baseline data can reveal potential problems.

C. Periodic quality assurance testing

Recommendations for periodic QA testing of treatment planning systems have been provided in chapter five of the TG53 report. The current task group endorses those recommendations for periodic QA of simulation software. Periodic QA should include a weekly review of any software errors, problems, and unusual occurrences with the simulation team members. The extent and frequency of treatment planning

TABLE IV. An example of abbreviated protocol for CT-simulation of patients with lung cancer.

SITE	Patient position	Immobilization	Setup	Protocol	Slice (mm)	Index (mm)	Scan limits	Contrast	Special instructions
LUNG	Supine. Chin extended. Arms above head, folded, may rest on 5 cm or 7 cm sponge	Alpha cradle registered to table with registration device.	Init. Ref. at carina and midplane or per MD instructions on Sim sheet.	ONC MED/LG THORAX 5×5	5	5	Chin to lung apex	125 ml Optiray 320 and/or 2 table spoons Esophocat	CAX drawn on patient's anterior and lateral surfaces. Per MD the CAX can be placed mid depth and midplane at highest level of thorax. Contrast given just before the scan. Start scanning after 1/2 contrast in.
				ONC MED/LG THORAX 3×3	3	3	Through target and CAX, most of lung		
				ONC MED/LG THORAX 5×5	5	5	Through rest of the lung		
				ONC MED/LG THORAX 8×8	8	8	Top of kidneys or per MD request		

software tests depend on the complexity and reliability of the software and the local clinical practice. It is recommended that extended testing (a subset of commissioning tests) be performed after installation of simulation software upgrades. After the CT-scanner software upgrade, a smaller set of image related tests should be performed on the CT-simulation software in addition to tests performed on the scanner.

Daily clinical operation should include a formal review of CT-simulation plans with a specific set of parameters to be reviewed.¹³ This review should be designed to detect errors associated with CT-simulation software. Often these reviews reveal errors in a timely fashion.

V. EVALUATION OF THE CT-SIMULATION PROCESS

Once the individual components of a CT-simulation system are evaluated, it is necessary to look at the entire simulation process and evaluate its functionality. Tasks performed in one step can affect accuracy of later steps and this can only be evaluated by testing the whole process. The simulation process QA has two primary areas of concern: (1) *Evaluation of the system functionality* and (2) *Data transfer tests*. Both areas and the QA aspects of each are addressed in this section.

A. Overall process tests

As described in Sec. I, the CT-simulation process consists of multiple steps. Often, to test the CT-simulation process, a geometric phantom is scanned and treatment planning is performed on the phantom. Phantoms described in Sec. IV^{53,56} are well suited for this purpose. Additionally, several other phantoms are commercially available. Appendix G provides a list of steps for evaluation of the overall process. The test may reveal systematic errors or incompatibilities in the treatment planning process. This is a very useful test during initial implementation of the CT-simulation program and we recommend that commissioning includes such testing.

A component of every CT-simulation QA program is planning of individual patient treatments. Each patient treatment plan and treatment has the potential to demonstrate errors associated with simulation hardware and software and the overall simulation process. The QA program should be

designed to include formal mechanism for reporting of errors, problems, and disagreements between treatment plans and actual patient treatments. This process can often reveal errors that are not included in the periodic QA program or problems that have not been considered in the past. The response to these errors should include communication between treatment team members about error source and corrective actions.

The CT-simulation program should include written procedures. Whenever possible, these procedures should identify sources of possible errors and suggest preventive measures. The procedures should be reviewed annually. Annual review of the CT-simulation program should include evaluation of past errors and efficacy of corrective measures. All members of the treatment planning team should be familiar with this document. Procedures and protocols within a department alleviate the constant questioning of how to setup and acquire data for a patient with a particular site of disease. Establishing procedures and protocols is the first step to concise CT-simulation. Procedures should be treatment site specific and include scan protocols with patient setup and immobilization, scan protocol, scan limits, contrast, special instructions, and possible beam arrangements. Table IV shows an abbreviated protocol for CT-simulation of patients with lung cancer. The following are some of the items that should be addressed in the procedure manual.

Patient positioning and immobilization: The success of conformal radiation therapy process begins with proper setup and immobilization. Positioning should be as comfortable as possible. Patients who are uncomfortable typically have poor treatment setup reproducibility. Patient setup design should consider location of critical structures and target volumes, patient overall health and flexibility, possible implants and anatomic anomalies, and available immobilization devices. Immobilization devices tremendously improve reproducibility and rigidity of the setup. Treatment devices should be evaluated to assess whether they are appropriate for a particular treatment site and how well they perform that task. Evaluation of an immobilization device should include whether the patient is comfortable and well immobilized through the entire course of therapy. Immobilization and treatment devices should not produce image artifacts and dis-

tortions. Immobilization performs two tasks: (1) Conforms to the patient's contours in a manner that allows minimal movement and (2) registers patient to the simulation/treatment table so treatment position can be easily and accurately reproduced. With use of an immobilization device that is registered to the table, the record and verify system can monitor treatment table coordinates with tight tolerance limits. Establishing a good immobilization protocol for each treatment site is the first step in assuring preciseness of a CT-simulation process.

The simulation procedures should include instructions for patient positioning. For example, depending on the target area of the brain the head can be extended, in the neutral position, rotated or the chin can be tucked. If this is not specified, patient position may be suboptimal and scan may have to be repeated. It is physician's responsibility to provide instructions for proper patient positioning.

Scan limits: Scan limits should be specified by the physician and should encompass volume long enough to create DRRs with enough anatomical information. The scan volume should be at least 5 cm or greater in the superior and inferior direction from the anticipated treatment volumes, longer volumes may be necessary for special situations (e.g., noncoplanar beams, vertex beams, etc.).

Scan protocol: The CT-scan parameters should be designed to optimize both axial and DRR image quality.^{2,3,11,20,53,69,70} The parameters influencing axial and DRR image quality include: kVp, mAs, slice thickness, slice spacing, spiral pitch, algorithms, scanned volume, total scan time, and field of view (FOV).^{11,14,20,23,31,33,34,36,53,68,69,71} Modern scanners come with preset protocols. Often, these may include "oncology" protocols which are designed for the CT-simulation process. Preset protocols should be reviewed by the local facility. The scan protocols should be reviewed at least annually for integrity, adequacy, and possible improvements.

Contrast: The use of contrast may be necessary for certain sites to better evaluate organs and tissue. Certain contrast materials that may have been used in conventional simulation may produce too many artifacts on the CT. For heterogeneity-based calculations, contrast can cause dose distribution errors due to artificial CT numbers and corresponding tissue densities. Contrast use should be reviewed with physicians periodically.

Special considerations and instructions: Each treatment site has unique considerations. These should be specified in CT-simulation procedures. Special considerations include: individual physician preferences, wiring of surgical scars for identification on CT images, scanning of patients with pacemakers and other implants, scanning of pediatric patients, patients under anesthesia, etc. A communication chain and responsibilities should be established for new problems and scans of patients with special needs.

Data acquisition: During the actual scanning of the patient it is important to observe and evaluate any voluntary or extreme involuntary movement such as the rise and fall of the chest. Unlike conventional simulation where the user is able to watch the motion of the patient under fluoroscopy

and therefore make some clinical decisions based on this movement, CT-simulation is a snapshot of anatomy. The patient should be relaxed and comfortable to improve daily treatment reproducibility.

Localization/markings: Localization begins once the data set has been acquired and transferred to the virtual simulation workstation. Isocenter can be placed based on the location of bony landmarks or based on structure centering. Initial observations regarding data transfer should include: patient orientation, image indexing, and FOV. Two things are imperative in localization: (1) the isocenter localized in the software must coincide with the isocenter marked on the patient and (2) tissue delineation is accurate and representative of the structure (i.e., the area outlined on the CT equals the actual area of the structure). System tests described in Sec. III C 1 ensure that the lasers are aligned. The transfer of isocenter coordinates from the simulation workstation to the CT couch should also be evaluated for accuracy. Once the CT couch has been moved the lasers should represent the same isocenter as localized on the workstation.

Patient marking is also a key issue in QA for CT-simulation. Along with well-designed immobilization, good laser marking on the patient's skin improves the patient positioning reproducibility. Long laser lines drawn on the patient's skin can establish the appropriate plane of treatment and minimize patient rotation and angulation on a day to day basis. It is not sufficient to only mark three small crosses on the patient's skin (one anterior or posterior and two laterals).

Virtual simulation: Once the isocenter has been marked on the patient, the patient may leave and virtual simulation can begin. This entails creating beams, placing blocks/MLC, and shifting isocenter while viewing the patient's imaged anatomy. All nondosimetric beam parameters should be tested as recommended by the TG53 and described in Sec. IV.

DRR and setup documentation: DRRs and setup documentation should always be inspected for accuracy and consistency. They should include correct patient information, correct treatment machine data, and correct treatment setup parameters. Any discrepancies should be evaluated for systematic errors.

B. Data transfer tests

Modern radiation treatment planning process involves multiple treatment planning computers often located on different networks. CT-simulation process requires accurate transfer of images (CT, MRI, PET, US), image related data, structures, interest points (isocenter, setup point), treatment beams, blocks and MLCs, DRRs, patient treatment setup information, and other parameters. Changes in configuration (software or hardware upgrades) of any scanner, computer, or network associated with the CT-simulation have a very strong potential of disturbing the process and introducing errors. Prior to upgrading or modifying any of the components, there should be a communication about which process may be disturbed and appropriate arrangements should be made. These include backup and relocation of data and

scheduled interruption of service. Chapter 7 of the TG53 report discusses in detail issues related to management of treatment planning systems and networks. The CT-simulation QA program should identify individuals responsible for system management and should include tests for verification of proper communication after system modifications.

VI. CONCLUSIONS

This task group report addresses quality assurance process for CT-simulation. The QA program described in this report is designed to improve accuracy of patient treatments and efficiency of the treatment planning process. Implementation of these recommendations will depend on circumstances of individual institutions. The basic principles presented in this document should be preserved whenever possible.

As with other components of radiation treatment planning and delivery, CT-simulation is a constantly evolving process. CT-scanners and virtual simulation software are continually being improved and new devices are being developed. The QA process described in this document provides a foundation for establishment of a CT-simulation QA program. This program should evolve and adapt as the device used for CT-simulation process change. The modified QA program should continue to ensure accurate and efficient delivery of radiation therapy.

APPENDIX A: INFORMATION FOR HOSPITAL ADMINISTRATION

1. Information for radiation oncology administration

Radiation oncology is reaching new pinnacles with continued advancement in treatment planning, delivery and verifications in several areas including volumetric imaging, optimized 3D dose calculations and display, computer-controlled treatment delivery equipment, and online treatment verification. Volume imaging with CT and magnetic resonance imaging (MRI), functional imaging with positron emission tomography (PET) scanning, interimage and in-trimage registration, and automatic image segmentation tools have enhanced our ability to define target volumes and critical structures with improved accuracy. The radiation treatment planning process that historically consisted of patient positioning and/or immobilization, patient imaging data acquisition, target and critical structure localization, radiation field design, and patient marking for treatment has radically changed with the introduction of dedicated CT-simulators in radiation therapy clinics. CT-simulator comprises of a CT-scanner, a laser localization system, and computer software that provides the capabilities of image processing and manipulation, target volume and critical structure segmentation and beam display in three dimensions. Simply, CT-simulation combines some of the functions of image-based three-dimensional treatment planning system and the conventional simulator. It attempts to integrate as much of the planning process as possible using exact anatomical information of the patient obtained from the 3D imaging data-set.

The initial concept of CT-simulator was to emulate the conventional simulation process on a contiguous CT data-set representing the patient. This idea was first proposed by Goitein and Abrams^{72,73} as beam's-eye-view (BEV) planning. In BEV planning, relevant segmented critical structures from CT contours are projected to a plane beyond the patient from the vantage of the radiation source to assure appropriate three-dimensional target coverage. This concept was further developed by Sherouse^{9–11} who introduced a system that could work like a simulator but used digital information derived from the patient imaging data-set. A patient treatment simulation could be completed on a virtual patient model with digitally reconstructed radiographs (DRR). DRR is simply a virtual radiographic projection of overlying anatomy (bone and tissue) in a beam's eye view. Therefore, the simulation process can be completed in a virtual domain without having the patient in the simulator room. This paradigm not only improves the accuracy of target localization but it also provides flexibility for the radiation oncologists to complete the simulation process at a time that is more conducive to their schedule. There is a proliferation of dedicated CT-simulators in radiation therapy clinics. CT-simulators have become so popular that many clinics are moving away from conventional simulators and are relying primarily on CT-simulators.

Virtual treatment simulation in an accurate and consistent manner is by no means easy to achieve since the virtual simulation process encompasses a number of tasks that have historically been done in either radiation oncology or diagnostic radiology. Scanning has been primarily performed in diagnostic radiology. Most radiology departments have well-established QA guidelines for CT-scanners in the context of diagnostic use. However, a CT-scanner used for virtual simulation has hardware requirements and priorities that differ from those of diagnostic radiology. These include the ability to acquire imaging data-set in exact treatment position with appropriate treatment accessories, precise target localization with respect to fiducial marks on skin surface, minimizing patient motion during the scan acquisition to avoid anatomic misalignment, and finally, adequate image storage and networking capabilities for an efficient virtual simulation setup. Once the CT images are transferred to the virtual simulation workstation, there are software requirements in manipulating imaging data to localize radiation targets and design fields accurately. Therefore, the QA of CT-simulators must include QA of CT-scanner, QA of the virtual simulation process and testing of the accuracy and performance of the patient marking system for setup reproducibility.

As noted by other AAPM task group reports, one of the objectives in radiation therapy is that the radiation dose delivered to the patient be within 5% of the prescribed dose.⁷⁴ To achieve this goal, the radiation oncology community has subsequently introduced many advanced devices and procedures in the treatment planning process. The complexity of these devices and procedures, however, makes the process vulnerable to random and systematic uncertainties. Considering the many steps involved in delivering dose to a target volume in a patient, each step must be performed with accu-

racy much better than 5% to achieve an overall accuracy of 5%. It is anticipated that better than 3% accuracy is required in tumor localization and dose calculations attain an overall accuracy of 5%. To avoid potential errors, QA is required in all steps of the radiation treatment process. Therefore, it is recommended that medical centers implement a QA program for equipment used for CT-simulation and the overall CT-simulation process. As recommended by the AAPM TG40,¹³ the CT-simulation QA program should be overseen by the radiation oncology Quality Assurance Committee (QAC). In accordance with the Joint Commission on the Accreditation of Health Care Organizations (JCAHO) requirements,^{75,76} it is recommended that the QAC implement a Policies and Procedure Manual for QA of CT-simulators, and an accompanying Quality Audit program.

In order to have an effective QA program, the radiation oncology department chairman along with administration should assure that appropriate resources are available. These resources include: qualified personnel, QA test equipment, available time for performance of QA program, and resources for education of involved personnel. Availability of these resources is a prerequisite for a successful QA program. Furthermore, the department chairman and the administration should ensure that QAC guidelines for CT-simulation QA are followed, including the performance of periodic QA, compliance with tolerance limits, and implementation of corrective maintenance actions.

The responsibilities of various team members with regard to a comprehensive radiation oncology QA program have already been described by the Task Group 40. We outline here the responsibilities of these members as they pertain to QA of the CT-simulation program.

Radiation oncologist: Radiation oncologists need to have the precise knowledge of the image-guided treatment simulation process. This knowledge is based on their adequate training in interpreting CT images, understanding the effects of motion and other image artifacts, understanding three-dimensional imaging reconstruction and graphic displays, and understanding of setup and treatment uncertainties to define adequate margins in radiation portal design. He or she is usually in daily contact with CT images. Therefore, the radiation oncologist is in the position to observe changes in image quality. The physician should be attentive to image quality changes, degradation, and artifacts. Any changes in image appearance should be immediately brought to the medical physicist's attention.

Radiation oncology physicist: The radiation oncology physicist is responsible for design, implementation, performance, and periodic review of the CT-simulation QA program. This person is also responsible for the acceptance testing and commissioning of CT-simulation equipment. The radiation oncology physicist should help define the specifications for the purchase of the CT-simulator. The physicist should be involved in the design of the facility and should assure that the radiation safety survey for the facility is performed. A radiation oncology physicist, diagnostic physicist, or a member of the radiation safety office can perform the survey. The radiation oncology physicist shall also certify

that the CT-simulator is performing according to the specification after it is installed and outline a written QA protocol which includes tests to be performed, tolerances and frequency of the tests. This person is responsible for assuring that all members of the CT-simulation team are properly trained and that ongoing training related to changes in the equipment and process is provided on timely basis. If the CT-scanner used for CT-simulation is located in the radiation oncology department, the radiation oncology physicist is responsible for QA of the scanner. If the scanner is located in the diagnostic radiology department, the radiation oncology physicist is responsible for assuring that the CT-scanner QA meets the requirements of the CT-simulation process. The radiation oncology physicist is always responsible for QA of CT-simulation software and CT-simulation process. It is clearly important that the radiation oncology physicist have a good understanding of the CT technology and familiarity with the acceptance testing procedures and protocols. If the radiation oncology physicist lacks that expertise, we recommend that the facility seek the services of a qualified diagnostic imaging medical physicist or another experienced radiation oncology physicist for acceptance testing of the CT-component of CT-simulator and to establish QA procedures.

Diagnostic physicist: If the scanner used for CT-simulation is located in the diagnostic radiology department, the diagnostic medical physicist is responsible for QA of the CT-scanner. This person is responsible for implementing recommendations of the therapy physicist and this report, to assure that the CT-scanner QA meets the needs of the CT-simulation process. The diagnostic medical physicist is responsible for timely communication with the radiation oncology physicist or a designee about any changes in the CT-scanner hardware or software or in the CT-scan process.

Radiation therapist: The radiation therapist involved in the CT-simulation process and operation of the CT-scanner is responsible for setup and scanning of patients according to the radiation oncologist's instructions. This person should understand the CT-simulation process and proper operation of the CT-scanner. The therapist should be able to recognize equipment malfunctions, image distortions, and potential problems that may affect patient safety and accuracy of radiation therapy delivery. Any of these issues should be brought to the medical physicist's attention. The radiation therapist is typically responsible for the performance of some portion of the QA associated with the CT-scanner and CT-simulation process.

Diagnostic radiologic technologist: Depending on the design and implementation of the CT-simulation process, the diagnostic radiologic technologist may be responsible for setup and scanning (CT-simulation) of patients according to the radiation oncologist's instructions. In this situation, expectations for this person are the same as for the radiation therapist. This person should receive initial and ongoing training regarding the CT-simulation process and its requirements.

Medical radiation dosimetrist: The dosimetrist is involved in the processing of patient images, normal structure contouring, placing of the treatment beams, and actually per-

forming the software portion of the CT-simulation process. The dosimetrist should be able to detect problems with patient images, CT-simulation software, and the treatment planning process. The dosimetrist may be responsible for performing various QA tasks associated with CT-simulation, treatment planning, and delivery.

CT-simulation can significantly improve the quality and efficiency of the radiation therapy process and patient care. It offers improved patient positioning, target delineation, treatment beam arrangement, and dose calculation. In many instances, it can simplify the simulation process for the patient since it utilizes patient images and relies only on a relatively short patient presence for setup and CT-scan. The decision to implement the CT-simulation process in a radiation oncology department is accompanied by several requirements. These requirements include the availability of appropriate CT-simulation equipment, qualified personnel, adequate space, and proper training. In addition, it requires resources for assuring proper and safe operation of the CT-simulation process and its components. Due to its sophistication, CT-simulation has the potential to introduce serious errors in patient treatment. While the tests outlined in this report do not guarantee an error-free system, they should minimize their probability. Without appropriate support from department administration, it is not feasible to create and maintain a strong QA program. Therefore, equipment, time, and personnel must be made available for the CT-simulation QA program.

2. Information for diagnostic radiology administration

Requirements for performance evaluation and QA of CT-scanners have been outlined in the AAPM Report No. 1,³⁷ AAPM Report No. 39,¹⁴ NCRP No. 99,⁴⁵ and the American College of Radiology Standard for Diagnostic Medical Physics Performance Monitoring of Computed Tomography Equipment. These requirements should be a component of the comprehensive QA program for CT-scanners in diagnostic radiology. As outlined in this document, CT-scanners used for CT-simulation, as a part of the radiation treatment planning process, have special performance requirements which must be verified for proper operation. Some of these performance requirements are in addition to the specifications already outlined for diagnostic CT-scanning; while other parameters have more stringent tolerance limits than those required for diagnostic scanning. Among these performance requirements are an increased need for mechanical integrity and accuracy of the CT-scanner gantry and table, addition of external patient positioning lasers whose accuracy must be verified, increased need for positional and spatial integrity of CT images, and increased need for accuracy of quantitative CT-scanner performance. Proper periodic evaluation of these parameters will undoubtedly add to the complexity of a diagnostic CT-scanner QA program.

Even though the number of CT-scanners located in radiation oncology departments is constantly increasing, many centers will continue to rely on treatment planning images from diagnostic radiology. We therefore recommend that di-

agnostic radiology departments incorporate in their QA program tests outlined in this report for those scanners which are used for CT-simulation. To further facilitate this process, we recommend that the diagnostic radiology department designate a liaison to the radiation oncology QA committee (QAC). This person will be responsible for proper communication between the two departments and will be responsible for ensuring that the radiation oncology QA needs are met in the diagnostic radiology QA program. The radiation oncology QAC and therapy medical physicist should have input to the acceptance testing and commissioning process of CT-scanners, and to the design of the CT-scanner QA program for those scanners which are used as CT-simulators. The input to the QA program design should include specification of tests, test frequency, tolerance limits, corrective actions, and QA assignments. We feel that a QA program designed jointly by diagnostic and therapy physicists can efficiently serve the needs of both departments.

In addition to the radiation oncology administration, it is the responsibility of the diagnostic radiology chairman and administration to ensure that the QA program for CT-scanners, which are used for CT-simulation, meets the recommendations outlined in this report. This includes the requirement that the appropriate amount of time for scanner QA be made available and that the therapy physicist and radiation oncology staff have adequate access to scanners which are used for CT-simulation. In general, it is assumed that the radiation oncology department is responsible for providing test equipment, QA phantoms, and, if necessary, labor for those tests which are not part of the routine diagnostic radiology scanner QA and which serve treatment planning purposes.

APPENDIX B: CT DOSIMETRY

1. CT dose descriptors

The basic CT dose descriptors have been in existence for many years and continue to be redefined as multidetector CT (MDCT) evolves. The primary measured value is known as the CT Dose Index (CTDI) and represents the integrated dose, along the z axis, from one *axial* CT-scan (one rotation of the x-ray tube).^{77–79} All other CT dose descriptors are derived from this primary measured value. It is important to note that the CTDI is always measured in the axial scan mode, and that doses for helical scan modes are calculated from the axial information.

The Code of Federal Regulations, 21 CFR 1020.33, section (h)(1) defines CTDI (denoted below as $CTDI_{FDA}$ due to its specific condition) as “the integral of dose profile along a line perpendicular to the tomographic plane divided by the product of the nominal tomographic section thickness and the number of tomograms produced in the single scan;”

$$CTDI_{FDA} = \frac{1}{nT} \int_{-7T}^{+7T} D(z) dz, \quad (B1)$$

where z is the position along a line perpendicular to the

tomographic plane, $D(z)$ is dose at position z , T is the nominal tomographic section thickness, and n is number of tomograms produced in a single scan.

Theoretically, the CTDI should be measured from plus to minus infinity. Since in practice the ion chamber to measure CTDI is typically 100 mm long, the IEC has specifically defined the CTDI measured with such a method as $CTDI_{100}$. In general, the $CTDI_{100}$ is different from $CTDI_{FDA}$. Readers should be cautious of any CTDI results if they are not clearly specified. The FDA is also moving to adopt $CTDI_{100}$.

As described later, CT dosimetry includes evaluation of CTDI dependence on the measurement point position in the field-of-view. For example, for body CT imaging, the CTDI is typically a factor or two higher at the surface than at the center of the field-of-view. The average CTDI across the field-of-view is given by the weighted CTDI ($CTDI_w$), where $CTDI_w = 2/3 \text{ CTDI}(\text{surface}) + 1/3 \text{ CTDI}(\text{center})$. $CTDI_w$ is defined using the “ f -factor” for air.

When performing a volumetric scan, dose profiles from individual scans are superimposed and summed to create a multiple scan profile. As the number of scans contributing to the multiple scan dose profile is increased, the average dose of the multiple dose profile reaches a limiting value. This limiting value is defined as the MSAD and can be expressed by the relation:⁷⁸

$$MSAD = \frac{1}{I} \int_{-I/2}^{I/2} D_{N,I}(z) dz, \quad (B2)$$

where $D_{N,I}(z)$ is the dose as a function of position for a multiple scan dose profile consisting of N scans separated by a constant distance between scans equal to I . Similar to the concerns regarding CTDI, the Z -axis extent of measurement for the MSAD has not been consistently defined. Using the $CTDI_{100}$ definition, the IEC has defined the term Volume $CTDI_w$ ($CTDI_{vol}$), which is equivalent to MSAD, but is explicitly measured using the $CTDI_{100}$ values,

$$CTDI_{vol} = \frac{N \cdot T}{I} \cdot CTDI_w, \quad (B3)$$

where N is the number of simultaneous axial scans per x-ray source rotation, T is the thickness of one axial scan (mm), and I is the table increment per axial scan (mm).

In spiral CT, the ratio of the table travel per rotation (I) to the total nominal beam width ($N \cdot T$) is referred to as pitch. Therefore,

$$CTDI_{vol} = \frac{1}{\text{pitch}} \cdot CTDI_w \quad (B4)$$

The $CTDI_w$ represents the average radiation dose over the x and y directions and the $CTDI_{vol}$ represents the average radiation dose over the x , y , and z directions. $CTDI_{vol}$ is useful indicator of the dose for a specific exam protocol, because it takes into account protocol specific information such as pitch.

Dose-Length Product (DLP) is used to define the total energy absorbed by a scanned volume from a given protocol. DLP represents integrated dose along the scan length,



Fig. 7. A body and head phantom for measurement of dose from CT-scans. Pencil ionization chamber is inserted in the center of the body phantom.

$$DLP \text{ (mGy cm)} = CTDI_{vol}(\text{mGy}) \cdot \text{scan length (cm)}. \quad (B5)$$

While two scan protocols may have the same $CTDI_{vol}$, their DLP value may be substantially different due to difference in scanned volume length. Several manufacturers include DLP information on the scanner control console for programmed scan protocols and scan lengths.

2. CT dose measurements

As described in the preceding section, patient dose from a CT-scan is assessed by measuring CTDI. Two CT dosimetry phantoms are commonly used. A 15 cm long, 16 cm diameter transparent acrylic cylinder is used for “head” protocol measurements. A 15 cm long, 32 cm diameter cylinder is used for “body” protocols. Five to nine holes are strategically placed in the phantoms to accept a pencil ionization chamber (Fig. 7). Phantom design requirements can be found in the Code of Federal Regulations 21 CFR 1020.23, Section (b)(6). Pencil ionization chambers are typically ten centimeters long and should be calibrated by accredited dosimetry laboratories. For the CTDI measurement, the phantom is placed in the center of the imaging plane resting on the tabletop or head holder. The phantom should be leveled and aligned with the central axis of the scanner. A single scan is then acquired through the center of the ionization chamber. The measurement procedure was described in detail in the AAPM report No. 39⁷⁹ and by Cacak.⁴⁰ The CTDI is calculated using the following equation:

$$CTDI_{100} = \frac{Rdg * C_{tp} * K_{el} * N_x * f_{med} * 100(\text{mm})}{\text{Total nominal beam width}(\text{mm})} [\text{cGy}], \quad (B6)$$

where

CTDI₁₀₀ is the Computed Tomography Dose Index [cGy] measured with 100 mm long ionization chamber,

Rdg is the electrometer reading,

C_{tp} is the temperature and pressure correction factor,

K_{el} is the electrometer calibration factor [C/rdg],

N_x is the chamber exposure calibration factor [R/C],

100 mm is the length of ionization chamber,

f_{med} is F factor which is used to convert exposure in air to absorbed dose in medium. At 70 keV effective energy f_{med} is 0.94 and 0.78 cGy/R for muscle and acrylic, respectively. For CTDI₁₀₀, F factor is defined to be 0.87 (air is assumed). For comparison purposes, it is important to know which F factor the manufacturer uses for defining CTDI.

The measured dose will change as a function of kVp setting, mA setting, scan time, slice thickness, beam filtration, etc. The CTDI is typically measured for a subset of standard combinations of scan parameters. Manufacturers commonly provide correction factor tables which can be used to correct CTDI measured at a standard combination of scan parameters to a desired scan parameter combination, alleviating the need to make specific measurements. At the time of scanner commissioning, the validity of these tables should be spot-checked.

APPENDIX C: RADIATION SAFETY SURVEY/SHIELDING EVALUATION

Shielding design for CT-scanner rooms has been described in the AAPM Report No. 39.¹⁴ The scanner itself provides shielding for primary radiation and scatter is the main source of radiation outside the scan plane. Scanner room shielding is, therefore, designed primarily for scatter radiation. The CT-scanner room shielding survey should be performed with a phantom in the scan plane. The phantom should approximate size and composition of pelvic area. Lucite or a water equivalent plastic phantom measuring 20 cm in diameter and 40 cm in length and width is sufficient for this procedure. Radiation exposure measurements should be performed with scan parameters that will result in the largest possible exposures [i.e., the largest slice thickness and the highest scan potential (kVp)]. Measured instantaneous exposure levels are proportional to CT-scanner mA setting. A typical survey procedure would include the following settings: 130 or 140 kVp, 10 mm collimator width, 200 mA, and exposure time sufficiently long to achieve stable radiation measurements which can be measured with a survey meter. As suggested in the NCRP Report No. 49,⁸⁰ with the scattering phantom in place, all walls, doors, and windows should be first evaluated for shielding integrity (gaps in the barrier, absence of shielding material) using a Geiger-Muller meter. Once the shielding integrity has been verified, and locations of highest radiation levels are found, a radiation

survey meter is used to measure instantaneous exposures. The weekly exposure level for a particular location is calculated using the following relationship:

$$X = 60 \cdot \dot{X} \cdot W \cdot T, \quad (C1)$$

where

X is the total weekly exposure [mR/week];

\dot{X} is the measured instantaneous exposure divided by measurement mA [mR/h·mA];

W is the weekly workload [mA-min/week] as defined in the AAPM Report No. 39;¹⁴

T is the occupancy factor as defined in the NCRP Report #49.⁸⁰

Shielding evaluation is performed only at the time of the initial scanner acceptance testing and (unless there are structural changes to the scanner room or when scanners are replaced) need not be performed again.

APPENDIX D: CT-SIMULATOR LASER QA

In this procedure, it is assumed that the device from Fig. 4 is used for testing. This phantom is used just as an example and other QA phantoms can be used to accomplish the same tests. For example, phantoms for treatment machine laser QA can be used.

The device consists of a Lucite base and two Lucite pegs mounted on the base. The pegs are 5 cm high, 2.8 cm wide, and 25 cm apart. Vertical and horizontal holes are drilled through the center of each peg [Fig. 4(b)]. The two holes, measuring 1 mm in diameter, meet inside the peg to form an inverted letter “T” [Fig. 4(b)]. Another vertical hole of the same diameter is drilled in the center of the base plate (between two pegs). The laser QA device is then attached to the scanner table using a registration bar or some other form of attachment. The device should be centered on the tabletop and positioned perfectly orthogonal to the long axis of the table.

Test method: (1) *Gantry lasers should accurately identify scan plane within the gantry opening*—If the centers of holes inside the pegs on the laser QA device are aligned with the gantry lasers and a single axial scan with a 1–2 mm slice width is acquired, an image like that shown in Fig. 8 will be generated. In the alignment process, horizontal side gantry lasers (left and right) are aligned with horizontal holes in pegs by raising or lowering the table. By moving the table in or out of the gantry, the vertical side lasers are aligned with the horizontal peg holes and the overhead axial gantry laser is aligned with the vertical holes. If the gantry lasers are aligned with the imaging plane then the image should show a well-defined inverted letter “T” in each peg [Fig. 8(a)]. If there is a partial image of the inverted letter “T,” or no image at all, then the gantry lasers are not aligned with the imaging plane [e.g., Fig. 8(b)]. If the images inside two pegs are not the same then the QA device is rotated with respect to the imaging plane. Most frequently, this indicates that the

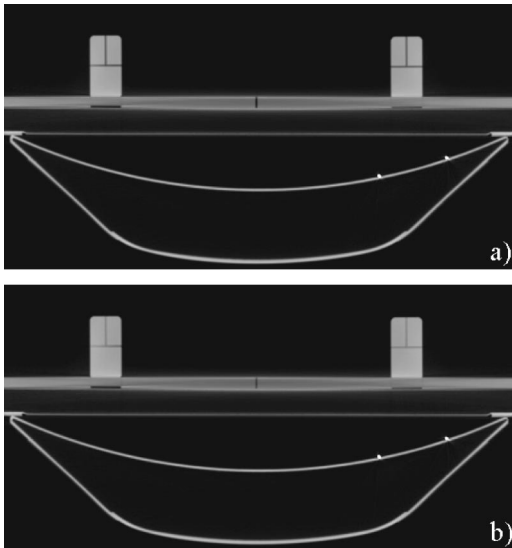

FIG. 8. CT image of laser QA device. (a) lasers aligned with imaging plane. (b) center of the QA device offset by 1 mm from the imaging plane.

tabletop is rotated with respect to the imaging plane (see Sec. III C 2).

(2) *Gantry lasers should be parallel and orthogonal with the scan plane and should intersect in the center of scan plane*—If the image in Fig. 8(a) shows a well-defined inverted letter “T” in each peg then, as described above, the gantry lasers are aligned with the imaging plane. When the table is raised and lowered from the table position used to acquire the image in Fig. 8(a) the vertical side gantry lasers and the overhead axial gantry laser should track the holes inside the pegs. If the lasers drift away from the holes then the lasers are not parallel with the imaging plane, or the couch is not traveling vertically parallel with the image plane.

The overhead sagittal gantry laser should be aligned with the center hole on the base plate of the QA device through the full range of couch vertical travel within the CT donut. If this laser drifts or does not touch the center hole at all then it may require alignment. If the horizontal gantry lasers are aligned with side holes in the pegs, they should track the holes the full length of the laser beam as the table is moved in and out of the gantry. During this test, the sagittal overhead laser should also track the center hole on the base plate. If either of the horizontal lasers, or the sagittal overhead laser, drifts away from peg holes, then they, or the couch, are not orthogonal with the imaging plane.

The measuring cursor option on the scanner can be used to evaluate if the gantry lasers intersect in the center of the imaging plane. The measuring cursor usually forms a cross. If the horizontal line of the measuring cursor is positioned through horizontal holes on both pegs in image in Fig. 8(a), and the vertical line of the cross hair through the hole in the center of the base plate, then the locator indicator for the cursor can be used to assess alignment accuracy. The loca-

tion indicator (x,y) for the cross-hair position should read (0, 0). If there is a different y value, then the horizontal gantry lasers are not aligned with the center of the imaging plane and should be adjusted if out of tolerance. If the x value is different, then the overhead laser is not properly aligned or, more importantly, the tabletop itself may be improperly installed (see Sec. III C 2).

(3) *Vertical side-wall lasers should be accurately spaced from imaging plane*—For this test, the laser QA device, described previously, is first aligned with well-aligned gantry lasers or directly with the image plane as described in test method (1) and Fig. 8(a). Using the digital longitudinal table indicator, the table is then retracted away from the gantry the distance equal to the predefined separation between the gantry and wall vertical lasers (often 500 mm). After the retraction, both vertical wall lasers should bisect the side holes on pegs. Misalignment indicates that the lasers are not properly spaced or that the couch travel is not correctly indicated.

(4) *Wall lasers should be parallel and orthogonal with the scan plane and should intersect at a point which is coincident with the center of the scan plane*—The geometry of side-mounted wall lasers is assessed in similar fashion as the gantry lasers, by aligning the QA device and moving the table vertically and longitudinally.

(5) *The overhead (sagittal) laser should be orthogonal to the imaging plane*—If the table is moved towards and away from the gantry the sagittal laser should touch the center hole in the QA device the full length of the laser beam. This indicates that the sagittal laser is orthogonal with the imaging plane and that the CT couch is traveling orthogonally, as well.

(6) *The overhead laser movement should be accurate, linear, and reproducible*—This can be tested by placing a ruler against the two pegs on the laser QA device across the tabletop. One of the ruler marks should be aligned with the sagittal laser (whose position should read zero) and the center hole in the QA device. By moving the laser various distances to the left and right, laser movement can be evaluated. For daily QA, the sagittal laser can be moved a predefined distance from the center hole to the center of each peg (125 mm). After movement, the laser should intersect the vertical hole in each of the pegs. This is a quick way to assess daily laser motion accuracy.

The image in Fig. 8(a) can also be used to daily assess CT image spatial integrity. The separation between the vertical holes in two pegs in Fig. 8(a) should measure 250 ± 1 mm using the scanner measuring tool. Shorter or longer distances may indicate image spatial distortion. Additionally, the laser QA device can be used to assess the table’s vertical and longitudinal movement accuracy. If the QA device is used for daily laser QA, the indicated table vertical and longitudinal position should be the same day to day when the device is aligned with lasers.

CT SIMULATOR QUALITY ASSURANCE REVIEW

A. Mechanical Checks

1. Couch Position Tolerance (tolerance $\pm 2\text{mm}$)

Height	<u>Digital Reading</u>	<u>Nominal Value</u>	<u>Sat.</u>	<u>Unsat.</u>
Aligned w/ pegs		388	<input type="checkbox"/>	<input type="checkbox"/>
	<u>Longitudinal</u>	<u>Digital Reading</u>	<u>Sat.</u>	<u>Unsat.</u>
	Initial Value		<input type="checkbox"/>	<input type="checkbox"/>
	Initial value + 500mm		<input type="checkbox"/>	<input type="checkbox"/>

2. Laser Alignment (tolerance $\pm 2\text{mm}$)

<u>Wall Lasers</u>	<u>Sat.</u>	<u>Unsat.</u>	<u>Comments</u>
Longitudinal tracking	<input type="checkbox"/>	<input type="checkbox"/>	_____
Vertical tracking	<input type="checkbox"/>	<input type="checkbox"/>	_____
<u>Sagittal Laser</u>			
Longitudinal tracking	<input type="checkbox"/>	<input type="checkbox"/>	_____
Vertical tracking	<input type="checkbox"/>	<input type="checkbox"/>	_____
<u>Gantry Side Laser</u>			
Longitudinal tracking	<input type="checkbox"/>	<input type="checkbox"/>	_____
Vertical tracking	<input type="checkbox"/>	<input type="checkbox"/>	_____
<u>Gantry Top Laser</u>			
Longitudinal tracking	<input type="checkbox"/>	<input type="checkbox"/>	_____
Vertical tracking	<input type="checkbox"/>	<input type="checkbox"/>	_____

3. Sagittal Laser

Coord. Left	<u>Sat.</u>	<u>Unsat.</u>	Center	<u>Sat.</u>	<u>Unsat.</u>	Right	<u>Sat.</u>	<u>Unsat.</u>
X(+ 125 mm) _____	<input type="checkbox"/>	<input type="checkbox"/>	(0 mm) _____	<input type="checkbox"/>	<input type="checkbox"/>	(-125 mm) _____	<input type="checkbox"/>	<input type="checkbox"/>

4. Laser/Radiation Beam Alignment

Coord. Left	<u>Sat.</u>	<u>Unsat.</u>	Center	<u>Sat.</u>	<u>Unsat.</u>	Right	<u>Sat.</u>	<u>Unsat.</u>
X(+ 125 mm) _____	<input type="checkbox"/>	<input type="checkbox"/>	(0 mm) _____	<input type="checkbox"/>	<input type="checkbox"/>	(-125 mm) _____	<input type="checkbox"/>	<input type="checkbox"/>
Y(0 mm) _____	<input type="checkbox"/>	<input type="checkbox"/>	(29 mm) _____	<input type="checkbox"/>	<input type="checkbox"/>	(0 mm) _____	<input type="checkbox"/>	<input type="checkbox"/>

Measurements by: _____ Date: _____

SAMPLE CT SIMULATOR LASER QA PROCEDURE AND FORM

- (1) Attach the laser QA device to the simulator tabletop.
- (2) Move the couch until the side holes in pegs are aligned with horizontal and vertical wall lasers. The table height indicator should agree with the value on the QA form (i.e., 388). Verify that both, left and right, wall lasers agree with holes in pegs. The tolerance for this test is ± 2 mm.
- (3) Note the longitudinal couch position.
- (4) Move the couch towards the gantry until holes in pegs align with left and right vertical gantry lasers.
- (5) The longitudinal couch position should change by the known displacement between the gantry lasers and wall lasers, with an accuracy of $+2$ mm.
- (6) Verify the alignment of the left and right horizontal gantry lasers with holes in pegs. The tolerance is ± 2 mm.
- (7) Verify the alignment of the center gantry laser with the center hole on the QA device. The tolerance is ± 2 mm.
- (8) Retract the couch until the vertical wall lasers are again aligned with holes in pegs. The longitudinal couch position should agree with the value in step (3).
- (9) Align the overhead sagittal laser with the center mark on the QA device using the remote control. The lateral position indicated on the remote control should be 0.0 ± 2 mm.
- (10) Align the overhead sagittal laser, using the remote control, with left and right pegs. The lateral position on the remote control should be $+125 \text{ mm} \pm 2$ mm and $-125 \text{ mm} \pm 2$ mm for left and right pegs, respectively.
- (11) Move the table manually towards the gantry and away from the gantry while observing the position of right and left horizontal wall lasers on the pegs and the position of the overhead sagittal laser. The lasers should not move away from holes by more than ± 2 mm.
- (12) Align holes in pegs with wall lasers and raise and lower the table while observing the position of right and left vertical wall lasers on the pegs and the position of the overhead sagittal laser. The lasers should not move away from holes by more than ± 2 mm.
- (13) Align holes in the QA device with gantry lasers.
- (14) Repeat steps 11 and 12 for gantry lasers.
- (15) Move the couch towards the gantry until holes in pegs again align with left and right gantry lasers.
- (16) Scan the registration device. The slice thickness and spacing should be 1.5 mm and 0 mm, respectively. The scan mode should be axial.
- (17) After the scan is complete open a cursor option on the scanner and choose the cross tool.
- (18) Align the cursor cross with the horizontal and vertical holes in the left peg. The X and Y values should be $+125 \text{ mm} \pm 2$ mm and $0 \text{ mm} \pm 2$ mm, respectively.

- (19) Align the cursor cross with the top of the center hole on the QA device. The X and Y values should be $+0 \text{ mm} \pm 2$ mm and $-29 \text{ mm} \pm 2$ mm, respectively.
- (20) Align the cursor cross with the horizontal and vertical holes in the right peg. The X and Y values should be $-125 \text{ mm} \pm 2$ mm and $0 \text{ mm} \pm 2$ mm, respectively.

APPENDIX E: SCANNER TABLE TESTS

Testing of the following parameters should be performed with the tabletop loaded with at least 150 lb (75 kg) of distributed the weight to simulate a patient.

Tools needed: Laser QA device from Sec. III C 1, ruler, and ready-pack film.

Test method: (1) *The couch/tabletop should be level and orthogonal with respect to the imaging plane*—One of the problems associated with scanners used for CT-simulation is the fact that a flat tabletop is generally an addition to the scanner, which may not have been considered during the scanner design. This can cause the flat-tabletop installation on the scanner couch base to be imprecise or irreproducible. This can also apply to tabletops provided and installed by the scanner manufacturer. Therefore, even if the scanner was installed properly and the couch base is level and orthogonal with the imaging plane (this should be verified during commissioning), the tabletop may still not be level and/or orthogonal with the imaging plane. Proper installation of the tabletop cannot be verified with a level alone but must be verified radiographically. A level shows only that the tabletop is level with respect to the “world,” and it does not necessarily indicate whether it is orthogonal with respect to the imaging plane.

To assure that the tabletop longitudinal axis of travel is perpendicular to the image acquisition plane (i.e., the tabletop is not rotated with respect to the imaging plane), the laser QA device is first placed as close to the head of the tabletop (gantry side) as possible. The device is then aligned with gantry lasers and a single image through the device is acquired. The device is then positioned as far as possible towards the foot of the table and again aligned with gantry lasers where a single image is acquired. The location of the laser QA device in two images should be identical. Using the scanner cursor tool, the location of the center hole in the QA device should be measured on both images. The location of the hole on two images should be within 2 mm agreement. The agreement demonstrates that couch axis of travel is perpendicular to the image acquisition plane.

The position of horizontal holes in both pegs on the QA device in both images should have the same coordinate within 2 mm when measured by the scanner cursor tool. Any disagreement between measured coordinates for the horizontal holes in the QA device for either one of the pegs, in either of the images, may be an indication that the tabletop is not level in the transverse direction, that the tabletop is not orthogonal to the imaging plane in the longitudinal direction, that the tabletop is twisted, or that couch longitudinal travel is introducing “roll” in the table as it travels.

For above described tests, it is assumed that the couch base is level in the axial and longitudinal direction with respect to the imaging plane and that the couch is not rotated. As stated above, this should be verified during commissioning. To verify that the base is not rotated with respect to the imaging plane, two small pieces of wire (1 to 2" long) are taped in the center of the couch top, one at the gantry side and one at the foot side (similar to the test above). The lateral coordinates of two wires in their respective images should be identical. To verify that the couch base is level in the axial direction, the couch top can be scanned in several places and scanner cursor tool can be used to evaluate if the couch base is level. To verify that the longitudinal couch axis is orthogonal to the imaging plane, two small pieces of wire can be taped to the couch top (in the same longitudinal position but laterally spaced as far as possible). Each wire should be oriented at 90° with respect to the other wire and at 45° with respect to the imaging plane. The wires are first scanned with the couch in the lowest vertical position and then in the highest achievable position. The separation between the wires in two images should be identical. Variation in wire separation in two images indicates that the couch base is not orthogonal with the imaging plane. This can be due to gantry or couch base tilt. Any discrepancies should be addressed during commissioning.

(2) *Table vertical and longitudinal motion according to digital indicators should be accurate and reproducible*—Table vertical and longitudinal digital indicators are used for patient treatment isocenter marking during CT-simulation.^{1,2,4,12} Therefore, the digital indicators and table motion accuracy directly affect the ability to accurately correlate internal patient anatomy with skin marks. A longitudinal motion accuracy test is inherent to the previously described laser QA wherein the separation between gantry and wall lasers was verified.

Longitudinal digitally indicated motion accuracy and reproducibility is tested by placing a longitudinally oriented, long ruler flat on the tabletop, and moving the table in and out of the gantry. Laser projection on the ruler is used to directly measure the distance traveled, and relative table position.

Vertical digitally indicated motion accuracy and reproducibility is tested by placing a long ruler vertically on the tabletop and observing a laser position on the ruler as the table is raised and lowered. Of course, care should be taken to ensure that the ruler is perpendicular to the table top for all measurements. Both, longitudinal and vertical digital table position indicators should be accurate within to 2 mm.

Some patient immobilization devices register directly to the scanner tabletop. These devices can register to the treatment machine tabletop as well. In such situation, it is possible to use scanner and treatment machine absolute table coordinates to position patients. Furthermore, treatment machine table coordinates can be entered in the record and verify system to verify correct patient positioning.

Accuracy of absolute scanner couch coordinates can be verified by observing couch coordinates reported by the scanner when verifying coincidence of scanner lasers and the

imaging plane (III C 1). Absolute table coordinates should be consistent with reference values to within ± 2 mm. Reference values should be obtained during commissioning or after adjustment of couch operation.

(3) *Table indexing and position under scanner control should be accurate*—This test has been described in detail by several authors.^{36,40} This test is similar to the preceding section except that the table is moved under scanner control rather than manually. A ready-pack film is taped on the tabletop and the film is irradiated at some predetermined fixed spacing with a series of narrow scans. This test can be performed in axial or spiral scan mode. The spacing between stripes on the film should correspond to the spacing used for the scan. Reproducibility of the table indexing can be checked by irradiating the above film twice. The table should be moved under scanner control for both scans. After processing the film, the lines from two scans should be superimposed.

Table indexing can alternatively be checked without exposing the film as described in the AAPM Report No. 39.¹⁴ Table indexing accuracy and reproducibility under scanner control should be accurate within ± 1 mm.

(4) *Flat tabletop should not contain any objectionable artifact producing objects*—During initial acceptance testing, the flat tabletop insert should be scanned to evaluate whether there are any objects in the tabletop which can produce clinically significant image artifacts (screws, etc.).

APPENDIX F: X-RAY GENERATOR TESTS

Typical tests of the x-ray generator include evaluation of the peak potential (kVp), half-value layer (HVL), current accuracy (mA), time accuracy (seconds), mAs linearity and reproducibility and, potentially, other tests like focal spot size.²⁰ Inaccurate performance of these parameters can affect the accuracy of CT numbers measured with the scanner and, potentially, the accuracy of heterogeneity-corrected dose calculations.

QA goals: CT-scanner x-ray generator measurements should be performed at installation or following replacement of major components in the x-ray generator system, such as the x-ray tube. Tests should include evaluation of

- (1) peak potential (kVp),
- (2) half-value layer (HVL),
- (3) mAs linearity,
- (4) mAs reproducibility,
- (5) time accuracy.

Tools needed: Evaluation of a CT-scanner x-ray generator can be somewhat difficult due to the rotating x-ray tube and the closed nature of most modern systems which impede invasive measurements. Invasive measurements are cumbersome, require manufacturer assistance, and are potentially dangerous for both equipment and personnel. Noninvasive measurements of x-ray generator performance parameters are appropriate and, in fact, preferred in a radiation oncology setting. Several noninvasive, commercially available devices

are capable of assessing kVp, time, and exposure. Each of the five performance parameters listed above can be assessed with noninvasive devices. HVL measurements can be performed with pencil ionization chamber and electrometer.⁸¹

Test method: For use of noninvasive measurements, the CT-scanner must be capable of “parking” the x-ray tube at the 12 o’clock position. The manufacturer should be able to provide assistance with this procedure as the utility which is used to park the x-ray tube is usually not a part of the main user interface and can sometimes be a hidden service utility.

Report No. 39 discusses evaluation of the x-ray generator system, and the reader is referred to that report for a detailed description of tests. The AAPM Report No. 25⁸² also provides information and procedures for accessing some of the generator performance parameters. For evaluation of all of the above five performance parameters, the x-ray tube is rotated to the 12 o’clock position and the table is placed at the lowest possible position within the gantry. The measurement device is centered on the table using the overhead gantry lasers. The scanner is programmed from the control console to evaluate various settings. For all measurements, the widest available collimator setting should be used.

(1) *kVp*—accuracy of all clinically used tube potential settings should be evaluated. Measured values should meet manufacturer specifications. In absence of the manufacturer specifications, Report No. 39 recommends that tube potential should be within ± 2 kV of indicated values for all power levels.

(2) *HVL*—Half-value layer should be evaluated for all clinically used tube potential settings. The HVL is specified in mm of aluminum. A set of thin sheets of aluminum, of varying thicknesses are required for HVL measurements. First, at a particular, fixed mAs setting the exposure (mR) of the open (unfiltered) beam is measured. Next, Al sheets are placed incrementally between the noninvasive detector and the x-ray tube. Exposure measurement is repeated with each addition of Al sheet. Half-value filtration is calculated from the Al thickness and the corresponding mR values. In the absence of manufacturer specifications, values found in the AAPM Report No. 25⁸² can be used.

As noted by Kruger,⁸¹ displacing the ionization chamber laterally from the scanner isocenter can significantly change measured HVL values, due to bow-tie filter.

(3) *mAs linearity*—This test is used to infer tube current through indirect measurement. The foundation for this test is that for a constant tube potential and slice width, the integral exposure (mR) should be a linear function of mAs. Therefore, for this test, relative exposure measurements are required. For all measurements, the exposure time should be kept constant (for example, 1 second) and the current should be varied through the range of available settings. The measurements should be performed for all clinically used tube potential settings. As specified in Report No. 39 (III A 7), for each tube potential, mR/mAs should be calculated. The coefficient of linearity relative to the mean of all values is then determined. The coefficient of linearity of mR/mAs between the mean of all values and any single value (absolute difference divided by sum) should be within 0.05.

(4) *mAs reproducibility*—For repeated exposure measurements at a fixed setting, the measured values should be reproducible within values specified by the manufacturer.

(5) *Time accuracy*—Scan time accuracy can be evaluated with the noninvasive meter. Time accuracy should be measured for all available settings which are used clinically. The measurements should meet manufacturer specifications.

APPENDIX G: SAMPLE OVERALL CT-SIMULATOR PROCESS TEST

A simple phantom with an opaque marker either inside or on the surface works well to test the overall process or phantoms previously described can be used. A scan should be acquired of the phantom with a slice thickness and index typical of a routine scan. The following is an outline of a typical process:

- (1) Scan phantom with a fiducial marker,
- (2) Check scan indexing based on length of phantom,
- (3) Transfer data to workstation,
- (4) Check orientation,
- (5) Outline external contour of phantom,
- (6) Calculate area and volume to determine accuracy of structure outlining,
- (7) Align isocenter to fiducial marker,
- (8) Move CT couch to isocenter coordinates,
- (9) Mark phantom insuring that lasers match fiducial mark,
- (10) Set field size,
- (11) Send data to RTP system,
- (12) Check orientation and beam parameters,
- (13) Check CT numbers if the phantom is heterogeneous,
- (14) Send data to a treatment machine,
- (15) Print DRRs and setup documentation,
- (16) Setup and verify phantom treatment.

^aAuthor to whom correspondence should be address: Department of Radiation Oncology, Washington University School of Medicine, 4921 Parkview, St. Louis, MO 63110; Electronic mail: mutic@radonc.wustl.edu

^bAdvisor.

¹E.K. Butker *et al.*, “Practical implementation of CT-simulation: The Emory experience,” in *A Practical Guide to 3-D Planning and Conformal Radiation Therapy*, edited by J.A. Purdy and G. Starkschall (Advanced Medical Publishing, Middleton, WI, 1999), pp. 58–59.

²*A Practical Guide to CT Simulation*, edited by L.R. Coia, T.E. Schultheiss, and G. Hanks (Advanced Medical Publishing, Madison, WI, 1995).

³J. Conway and M.H. Robinson, “CT virtual simulation,” *Br. J. Radiol.* **70**, S106–S118 (1997).

⁴*CT Simulation for Radiotherapy*, edited by S.K. Jani (Medical Physics Publishing, Madison, WI, 1993).

⁵T. Kushima and M. Kono, “New development of integrated CT simulation system for radiation therapy planning,” *Kobe J. Med. Sci.* **39**, 197–213 (1993).

⁶J.M. Michalski, J.A. Purdy, W. Harms, and J.W. Matthews, “The CT-simulation 3-D treatment planning process,” *Front. Radiat. Ther. Oncol.* **29**, 43–56 (1996).

⁷Y. Nagata *et al.*, “CT simulator: a new 3-D planning and simulating system for radiotherapy: Part 2. Clinical application,” *Int. J. Radiat. Oncol., Biol., Phys.* **18**, 505–513 (1990).

⁸T. Nishidai *et al.*, “CT simulator: a new 3-D planning and simulating system for radiotherapy: Part 1. Description of system,” *Int. J. Radiat. Oncol., Biol., Phys.* **18**, 499–504 (1990).

⁹G. Sherouse, K.L. Mosher, K. Novins, E.L. Rosenman, and E.L. Chaney, “Virtual simulation: concept and implementation,” in *Ninth International*

- Conference on the Use of Computers in Radiation Therapy*, edited by I.A.D. Bruinvis, P.H. van der Giessen, H.J. van Kleffens, and F.W. Witkamper (North-Holland, 1987), pp. 433–436.
- 10 G.W. Sherouse, J.D. Bourland, and K. Reynolds, "Virtual simulation in the clinical setting: some practical considerations," *Int. J. Radiat. Oncol., Biol., Phys.* **19**, 1059–1065 (1990).
 - 11 G.W. Sherouse, K. Novins, and E.L. Chaney, "Computation of digitally reconstructed radiographs for use in radiotherapy treatment design," *Int. J. Radiat. Oncol., Biol., Phys.* **18**, 651–658 (1990).
 - 12 J. Van Dyk and J.S. Taylor, "CT-simulators," in *The Modern Technology for Radiation Oncology: A Compendium for Medical Physicists and Radiation Oncologists*, edited by J. Van Dyk (Medical Physics Publishing, Madison, WI, 1999), pp. 131–168.
 - 13 G.J. Kutcher et al., "Comprehensive QA for radiation oncology: report of AAPM Radiation Therapy Committee Task Group 40," *Med. Phys.* **21**, 581–618 (1994).
 - 14 AAPM, Report No. 39. *Specification and Acceptance Testing of Computed Tomography Scanners* (American Institute of Physics, New York, 1993).
 - 15 B. Fraass et al., "American Association of Physicists in Medicine Radiation Therapy Committee Task Group 53: quality assurance for clinical radiotherapy treatment planning," *Med. Phys.* **25**, 1773–1829 (1998).
 - 16 R.L. Gerber and J.A. Purdy, "Quality assurance procedures and performance testing for CT-simulators," in *A Practical Guide to 3-D Planning and Conformal Radiation Therapy*, edited by J.A. Purdy and G. Starkschall (Advanced Medical Publishing, Inc., Middleton, WI, 1999), pp. 123–132.
 - 17 J. Van Dyk and K. Mah, "Simulation and imaging for radiation therapy planning," in *Radiotherapy Physics in Practice*, 2nd ed., edited by J.R. Williams and T.I. Thwaites (Oxford University Press, Oxford, England, 2000), pp. 118–149.
 - 18 K. Mah, C.E. Danjoux, S. Manship, N. Makhani, M. Cardoso, and K.E. Sixel, "Computed tomographic simulation of craniospinal fields in pediatric patients: improved treatment accuracy and patient comfort," *Int. J. Radiat. Oncol., Biol., Phys.* **41**, 997–1003 (1998).
 - 19 E.K. Butker, D.J. Helton, J.W. Keller, I.L. Hughes, T. Crenshaw, and L.W. Davis, "A totally integrated simulation technique for three-field breast treatment using a CT simulator," *Med. Phys.* **23**, 1809–1814 (1996).
 - 20 T.S. Curry, J.E. Dowdey, and R.C. Murry, *Christensen's Physics of Diagnostic Radiology*, 4th ed. (Lea & Febiger, PA, Malvern, 1990).
 - 21 S.H. Fox, "CT tube technology," in *Medical CT and Ultrasound: Current Technology and Applications: Proceedings of the 1995 AAPM Summer School*, edited by L.W. Goldman and J.B. Fowlkes (Advanced Medical Publishing, Madison, WI, 1995), pp. 350–357.
 - 22 W.A. Kalender, W. Seissler, E. Klotz, and P. Vock, "Spiral volumetric CT with single-breath-hold technique, continuous transport, and continuous scanner rotation," *Radiology* **176**, 181–183 (1990).
 - 23 W.A. Kalender, "Principles and performance of spiral CT," in *Medical CT and Ultrasound: Current Technology and Applications*, edited by L.W. Goldman and J.B. Fowlkes (Advanced Medical Publishing, Madison, WI, 1995), pp. 379–410.
 - 24 W.A. Kalender and A. Polacin, "Physical performance characteristics of spiral CT scanning," *Med. Phys.* **18**, 910–915 (1991).
 - 25 K. Klingenberg-Regn, S. Schaller, T. Flohr, B. Ohnesorge, A.F. Kopp, and U. Baum, "Subsecond multi-slice computed tomography: basics and applications," *Eur. J. Radiol.* **31**, 110–124 (1999).
 - 26 H. Hu, "Multi-slice helical CT: scan and reconstruction," *Med. Phys.* **26**, 5–18 (1999).
 - 27 T. Fuchs, M. Kachelriess, and W.A. Kalender, "Technical advances in multi-slice spiral CT," *Eur. J. Radiol.* **36**, 69–73 (2000).
 - 28 H.D. Suit et al., "Potential for improvement in radiation therapy," *Int. J. Radiat. Oncol., Biol., Phys.* **14**, 777–786 (1988).
 - 29 C.R. Ramsey, D. Scaperth, D. Arwood, and A.L. Oliver, "Clinical efficacy of respiratory gated conformal radiation therapy," *Med. Dosim* **24**, 115–119 (1999).
 - 30 K. Ohara et al., "Irradiation synchronized with respiration gate," *Int. J. Radiat. Oncol., Biol., Phys.* **17**, 853–857 (1989).
 - 31 C.H. McCollough and F.E. Zink, "Performance evaluation of a multi-slice CT system," *Med. Phys.* **26**, 2223–2230 (1999).
 - 32 C.A. Perez et al., "Design of a fully integrated three-dimensional computed tomography simulator and preliminary clinical evaluation," *Int. J. Radiat. Oncol., Biol., Phys.* **30**, 887–897 (1994).
 - 33 J.L. Garcia-Ramirez, S. Mutic, J.F. Dempsey, D.A. Low, and J.A. Purdy, "Performance evaluation of an 85 cm bore x-ray computed tomography scanner designed for radiation oncology and comparison with current diagnostic CT scanners," *Int. J. Radiat. Oncol., Biol., Phys.* **52**, 1123–1131 (2002).
 - 34 D. Loo, "CT acceptance testing," in *Specification, Acceptance Testing and Quality Control of Diagnostic X-ray Imaging Equipment*, edited by J.A. Seibert, G.T. Barnes, and R.G. Gould, Proceedings of AAPM Summer School (American Institute of Physics, New York, 1991).
 - 35 C.H. McCollough, and F.E. Zink, "Quality control and acceptance testing of CT systems," in *Medical CT and Ultrasound: Current Technology and Applications*, edited by L.W. Goldman and J.B. Fowlkes, Proceedings of the 1995 AAPM Summer School (Advanced Medical Publishing, Madison, WI, 1995), pp. 350–357.
 - 36 C.H. McCollough and F.E. Zink, "Performance evaluation of CT systems," *Radiological Society of North America Categorical Course in Diagnostic Radiology Physics* (CT and US Cross-sectional Imaging, Oak Brook, IL, 2000).
 - 37 AAPM, Report No. 1, *Phantoms for performance Evaluation and quality assurance of CT Scanners* (American Association of Physicists in Medicine, New York, 1977).
 - 38 M. Stovall et al., "Fetal dose from radiotherapy with photon beams: report of AAPM Radiation Therapy Committee Task Group No. 36," *Med. Phys.* **22**, 63–82 (1995).
 - 39 National Council on Radiation Protection and Measurements (NCRP) Report Number 91. Recommendations on limits for exposure to ionizing radiation, Bethesda, MD, 1987.
 - 40 R. Cacak, "Quality control for computed tomography scanners," in *Computed Tomography*, 2nd ed., edited by E. Seeram (W.B. Saunders Company, Philadelphia, PA, 2001) pp. 385–407.
 - 41 R.L. Dixon and K.E. Ekstrand, "A film dosimetry system for use in computed tomography," *Radiology* **127**, 255–258 (1978).
 - 42 J.A. Sorenson, "Technique for evaluating radiation beam image slice parameters of CT scanners," *Med. Phys.* **6**, 68–69 (1979).
 - 43 R.A. Brooks and G.D. Chiro, "Slice geometry in computer assisted tomography," *J. Comput. Assist. Tomogr.* **1**, 191–199 (1977).
 - 44 CFR 21.1020.33, 1984, pp. 598–603.
 - 45 National Council on Radiation Protection and Measurements (NCRP), Report Number 99, Quality assurance for diagnostic imaging equipment. Bethesda, MD, 1988.
 - 46 P.F. Judy, "The line spread function and modulation transfer function of a computed tomographic scanner," *J. Comput. Assist. Tomogr.* **3**, 189–195 (1976).
 - 47 S.M. Bentzen, "Evaluation of the spatial resolution of a CT scanner by direct analysis of the edge response function," *Med. Phys.* **10**, 579–581 (1983).
 - 48 N.J. Schneiders and S.C. Bushong, "Single-step calculation of the MTF from ERF," *Med. Phys.* **5**, 31–33 (1978).
 - 49 E.L. Nickoloff and R. Riley, "A simplified approach for modulation transfer function determinations in computed tomography," *Med. Phys.* **12**, 437–442 (1985).
 - 50 E.L. Nickoloff, "Measurement of the PSF for a CT scanner: appropriate wire diameter and pixel size," *Phys. Med. Biol.* **3**, 149–155 (1988).
 - 51 R.T. Droege and R.L. Morin, "A practical method to measure the MTF of CT scanners," *Med. Phys.* **9**, 758–760 (1982).
 - 52 P.M. Joseph and C.D. Stockham, "The influence of modulation transfer function shape on computed tomographic image quality," *Radiology* **145**, 179–185 (1982).
 - 53 K.P. McGee, I.J. Das, and C. Sims, "Evaluation of digitally reconstructed radiographs (DRRs) used for clinical radiotherapy: a phantom study," *Med. Phys.* **22**, 1815–1827 (1995).
 - 54 Y. Yu et al., "Permanent prostate seed implant brachytherapy: report of the American Association of Physicists in Medicine Task Group No. 64," *Med. Phys.* **26**, 2054–2076 (1999).
 - 55 K.P. McGee and I.J. Das, "Commissioning, acceptance testing, and quality assurance of a CT simulator," in *A Practical Guide to CT Simulation*, edited by L.R. Coia, T.E. Schultheiss, and G.E. Hanks (Advanced Medical Publishing, Madison, WI, 1995), pp. 39–50.
 - 56 T.C. Craig, D. Brochu, and J. Van Dyk, "A quality assurance phantom for three-dimensional radiation treatment planning," *Int. J. Radiat. Oncol., Biol., Phys.* **44**, 955–966 (1999).
 - 57 National Electrical Manufacturers Association (NEMA), DICOM PS 3 (set), Digital Imaging Communications in Medicine (DICOM), 1998.

- ⁵⁸S. Mutic *et al.*, “Multimodality image registration quality assurance for conformal three-dimensional treatment planning,” *Int. J. Radiat. Oncol., Biol., Phys.* **51**, 255–260 (2001).
- ⁵⁹A.L. Boyer, T.G. Ochransky, C.E. Nyerick, T.J. Waldron, and C.J. Huntzinger, “Clinical dosimetry for implementation of a multileaf collimator,” *Med. Phys.* **19**, 1255–1261 (1992).
- ⁶⁰A. Brahme, “Design principles and clinical possibilities with new generation of radiotherapy equipment,” *Acta Oncol.* **26**, 403–412 (1987).
- ⁶¹I.J. Das, G.E. Desobry, S.W. McNeely, E.C. Cheng, and T.E. Schultheiss, “Beam characteristics of a retrofitted double-focused multileaf collimator,” *Med. Phys.* **25**, 1676–1684 (1998).
- ⁶²A. Frazier *et al.*, “Dosimetric evaluation of the conformation of the multileaf collimator to irregularly shaped fields,” *Int. J. Radiat. Oncol., Biol., Phys.* **33**, 1229–1238 (1995).
- ⁶³J.M. Galvin, A.R. Smith, and B. Lally, “Characterization of a multileaf collimator system,” *Int. J. Radiat. Oncol., Biol., Phys.* **25**, 181–192 (1993).
- ⁶⁴D. Georg, F. Julia, E. Briot, D. Huyskens, U. Wolff, and A. Duetrix, “Dosimetric comparison of an integrated multileaf-collimator versus a conventional collimator,” *Phys. Med. Biol.* **42**, 2285–2303 (1997).
- ⁶⁵M.S. Huq, Y. Yu, Z.P. Chen, and N. Suntharalingam, “Dosimetric characteristics of a commercial multileaf collimator,” *Med. Phys.* **22**, 241–247 (1995).
- ⁶⁶T.J. Jordan and P.C. Williams, “The design and performance characteristics of a multileaf collimator,” *Phys. Med. Biol.* **39**, 231–251 (1994).
- ⁶⁷J.R. Palta, D.K. Yeung, and V. Frouhar, “Dosimetric considerations for a multileaf collimator system,” *Med. Phys.* **23**, 1219–1224 (1996).
- ⁶⁸I.J. Das *et al.*, “Use of multiplanar reformatted radiographic and digitally reconstructed radiographic images for planning conformal radiation therapy,” *Radiographics* **15**, 1483–1488 (1995).
- ⁶⁹M.L. Bahner, J. Debus, A. Zabel, S. Levegrun, and G. Van Kaick, “Digitally reconstructed radiographs from abdominal CT scans as a new tool for radiotherapy planning,” *Invest. Radiol.* **34**, 643–647 (1999).
- ⁷⁰C. Yang *et al.*, “Use of digitally reconstructed radiographs in radiotherapy treatment planning and verification,” *Australas Radiol.* **44**, 439–443 (2000).
- ⁷¹W.A. Kalender, A. Polacin, and C. Suss, “A comparison of conventional and spiral CT: an experimental study on the detection of spherical lesions [published erratum appears in *J. Comput. Assist. Tomogr.* 1994 Jul-Aug, 18(4):671],” *J. Comput. Assist. Tomogr.* **18**, 167–176 (1994).
- ⁷²M. Goitein and M. Abrams, “Multi-dimensional treatment planning: I. Delineation of anatomy,” *Int. J. Radiat. Oncol., Biol., Phys.* **9**, 777–787 (1983).
- ⁷³M. Goitein, M. Abrams, D. Rowell, H. Pollari, and J. Wiles, “Multi-dimensional treatment planning: II. Beam’s eye-view, back projection, and projection through CT sections,” *Int. J. Radiat. Oncol., Biol., Phys.* **9**, 789–797 (1983).
- ⁷⁴International Commission on Radiation Units and Measurements (ICRU), *Determination of absorbed dose in patients irradiated by beams of x- or gamma-rays in radiotherapy process*, Bethesda, MD, 1976.
- ⁷⁵Joint Commission on the Accreditation of Healthcare Organizations: *Radiation Services: Quality assurance standards*, 1987.
- ⁷⁶Joint Commission on the Accreditation of Healthcare Organizations: *Radiation Services: Quality assurance standards*, 1992.
- ⁷⁷H.D. Nagel, *Radiation Exposure in Computed Tomography*, (COCIR, Frankfurt, 2000).
- ⁷⁸T.B. Shope, R.M. Gagne, and G.C. Johnson, “A method for describing the doses delivered by transmission x-ray computed tomography,” *Med. Phys.* **8**, 488–495 (1981).
- ⁷⁹AAPM, Report No. 31, *Standardized Methods for Measuring Diagnostic X-ray Exposures* (American Institute of Physics, New York, 1990).
- ⁸⁰NCRP, *Structural Shielding Design and Evaluation for Medical use of X rays and Gamma Rays of Energies up to 10 MeV*, (National Council on Radiation Protection and Measurements, Washington, DC, 1976).
- ⁸¹R.L. Kruger, C.H. McCollough, and F.E. Zink, “Measurement of half-value layer in x-ray CT: a comparison of two noninvasive techniques,” *Med. Phys.* **27**, 1915–1919 (2000).
- ⁸²AAPM, Report No. 25, *Protocols for the Radiation Safety Surveys of Diagnostic Radiological Equipment* (American Institute of Physics, New York, 1988).