

**PREVENTIVE MAINTENANCE MANUAL  
FOR VIRGINIA SCHOOL BUSES**

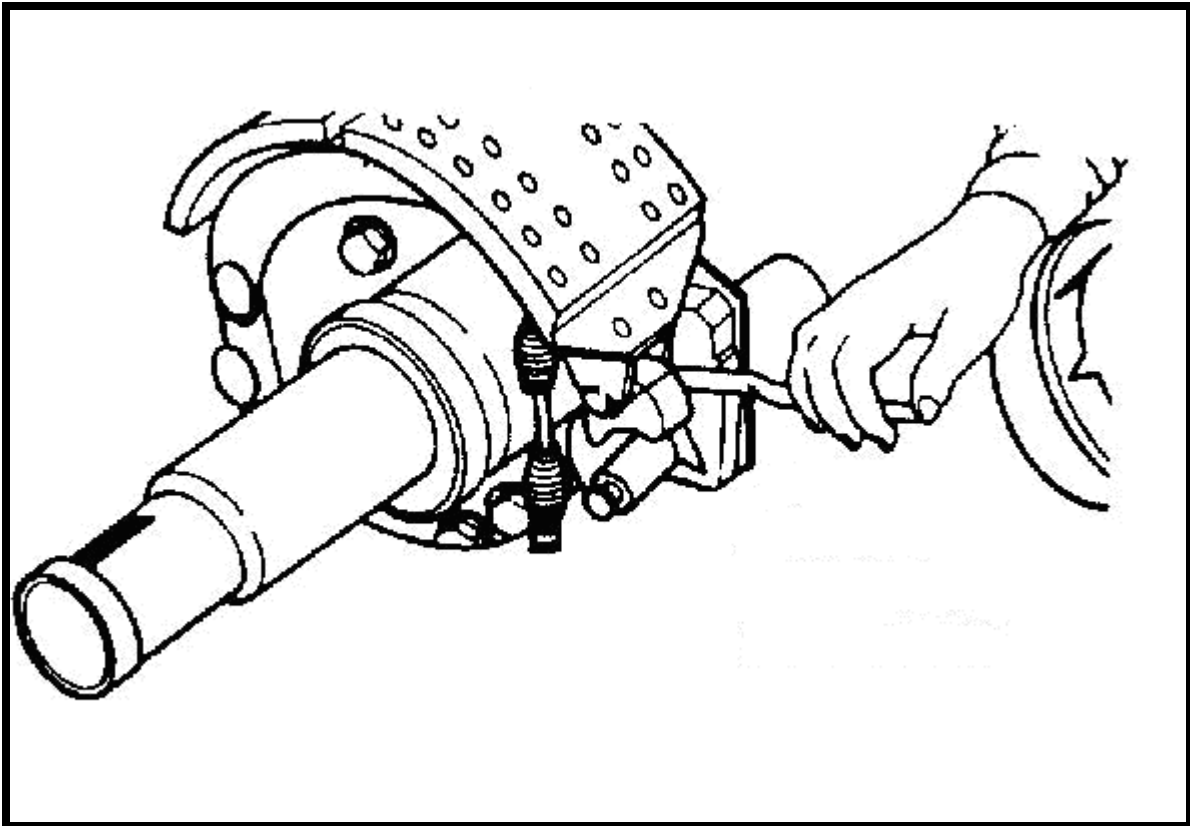

**Virginia Department of Education**

## **FOREWORD**

The purpose of this publication is to provide information regarding preventive maintenance, which is essential to the safe and efficient operation of school buses. An effective maintenance program can reduce accidents, downtime, and maintenance costs, as well as improve driver morale and public relations.

The driver's daily pre-trip inspection is the first step in preventive maintenance. Proper training and supervision are needed to make drivers aware of their responsibilities. An open line of communication among drivers, bus shop personnel, and school administrators is a must.

To control losses and protect a school division's investment in a fleet of buses, it is important to inspect and maintain all school buses systematically and conscientiously.

Accurate maintenance records are essential in determining the effectiveness of a preventive maintenance program.

This publication should prove helpful to persons initiating preventive maintenance programs or considering changes to existing programs.

# Table of Contents

Section I - Driver's daily pre-trip inspection	4
Pre-trip inspection procedures	
Pre-trip inspection step-by-step description	
Driver's pre-trip inspection report	
Monthly pre-trip inspection form	
Section II - Inspection schedules and guidelines	15
Inspection form #1	
Guidelines for inspections	
Section III - Shop records and inventory control	143
School bus garage repair order	
Parts and supplies inventory	
Fuel and lubricant reports	

## SECTION I

### DRIVER'S DAILY PRE-TRIP INSPECTION

Drivers are a critical component of an effective school bus preventive maintenance program. While the technician sees a bus periodically, the driver uses that bus every day. By making effective inspections before each daily trip and noticing how the bus performs during each trip, the driver often can detect early signs of developing mechanical problems.

**Drivers** are responsible for checking, recording, and reporting the mechanical condition of their buses. The *Regulations Governing Pupil Transportation* state:

#### **8 VAC 20-70-380. Pre-trip safety inspection.**

"Prior to the initial transporting of children each day, the **drivers** of school and activity buses shall perform a daily pre-trip safety inspection of the vehicle. The items checked and recorded shall be at least equal to the pre-trip inspection procedure in the Preventive Maintenance Manual for Virginia School Buses issued by the Department of Education."

Regardless of whether drivers find any defects, they should submit written bus condition reports that are accurate and complete.

Included in this publication are sample forms to be used in inspecting and reporting defects daily and monthly. Procedures in excess of those required by regulation for reporting the condition of school buses should be established to meet the needs of individual divisions.

# DAILY PRE-TRIP INSPECTION PROCEDURES

## A. FRONT OF BUS

1. Check Under Bus for Leaks
2. In the Engine Compartment, Check:
  - a. Oil Level
  - b. Coolant Level
  - c. Power Steering Fluid Level
  - d. Water Pump Looseness
  - e. Alternator Looseness
  - f. Air Compressor Looseness
  - g. Air Leaks
  - h. Brake Master Cylinder Leaks
  - i. All Belts

## A. INSIDE BUS

1. Start Engine & Check:
  - a. Oil Pressure
  - b. Alternator Voltage/Amps
  - c. Air Pressure & Air Brake Check
  - d. Steering Play
  - e. Parking Brake
  - f. All Mirrors & Windshield
  - g. Wipers & Washers
  - h. Light Indicators
  - i. Horn(s)
  - j. Heaters & Defrosters
  - k. All Safety Equipment

## B. TURN ON ALL LIGHTS & EXIT BUS

## C. START AT RIGHT FRONT WHEEL (Entrance Door Side)

1. Check:
  - a. Hub Oil Seal
  - b. Rim & Lug Nuts
  - c. Tire & Tread
  - d. Spring & Mounts
  - e. Shock Absorber
  - f. Air Brake Slack Adjuster & Chamber
  - g. All Brake Hoses
  - h. Drum or Rotor

## E. GO TO FRONT OF BUS

1. Check:
  - a. Entrance Door & All Front Mirrors
  - b. All Front Lights

## F. LEFT FRONT WHEEL/AREA (Driver side)

1. Check:
  - a. Hub Oil Seal
  - b. Rim & Lug Nuts
  - c. Tire & Tread
  - d. Spring & Mounts
  - e. Shock Absorber
  - f. Air Brake Slack Adjuster & Chamber
  - g. All Brake Hoses
  - h. Drum or Rotor
  - i. Steering Box
  - j. Steering Linkage

## G. UNDER BUS (Driver Side)

1. Check:
  - a. Drive Shaft & Guards
  - b. Exhaust System
  - c. Frame

## H. LEFT REAR WHEEL (Driver Side)

1. Check:
  - a. Hub Oil Seal
  - b. Rims & Lug Nuts
  - c. Tires & Treads
  - d. Spring & Mounts
  - e. Shock Absorber
  - f. Air Brake Slack Adjuster & Chamber
  - g. All Brake Hoses
  - h. Drum or Rotor

## I. REAR OF BUS

1. Check
  - a. All Lights
  - b. All Reflectors
  - c. Rear Emergency Door/Exit

## J. RIGHT REAR WHEEL (Entrance Door Side)

1. Check:
  - a. Hub Oil Seal
  - b. Rim & Lug Nuts
  - c. Tire & Tread
  - d. Spring & Mounts
  - e. Shock Absorber
  - f. Air Brake Slack Adjuster & Chamber
  - g. All Brake Hoses
  - h. Drum or Rotor

## K. FUEL AREA

1. Check:
  - a. Fuel Tank
  - b. Fuel Leaks

## L. PASSENGER AREA INSIDE BUS

1. Check:
  - a. Entrance Door
  - b. Handrail(s), Steps & Step Well
  - c. All Seats
  - d. All Emergency Exits
  - e. All Emergency Equipment

## M. FINAL CHECKS

1. Check:
  - a. Brake & Back-up Lights
  - b. Transmission & Clutch
  - c. Brakes
  - d. Steering

## DESCRIPTION OF STEP-BY-STEP DAILY BUS PRE-TRIP INSPECTION

<b>A. FRONT OF BUS</b>	
<b>1. Check Under Bus for Leaks</b>	
<ul style="list-style-type: none"> <li>• Look for wet spots on the ground.</li> </ul>	
<ul style="list-style-type: none"> <li>• The area may be darker, shine or slick.</li> </ul>	
<ul style="list-style-type: none"> <li>• Green or pinkish fluid may indicate antifreeze; red fluid may indicate power steering fluid; &amp; black fluid may be oil.</li> </ul>	
<b>2. Check Engine Compartment</b>	
<ul style="list-style-type: none"> <li>• <u>Oil Level</u>: pull dipstick &amp; check level when the engine is cold.</li> </ul>	
<ul style="list-style-type: none"> <li>• <u>Coolant Level</u>: look for green or pinkish fluid level in an indicator eye on the radiator. Some buses may have an overflow container and check that it is at least half full of coolant. <b>DO NOT REMOVE THE RADIATOR CAP TO CHECK FOR ANTIFREEZE!</b></li> </ul>	
<ul style="list-style-type: none"> <li>• <u>Power Steering Fluid</u>: remove the cap on reservoir and check level when the engine is cold.</li> </ul>	
<ul style="list-style-type: none"> <li>• <u>Water Pump</u>: check if any mounting bolts are missing.</li> </ul>	
<ul style="list-style-type: none"> <li>• <u>Alternator</u>: check if any mounting bolts are missing or if belt is loose.</li> </ul>	
<ul style="list-style-type: none"> <li>• <u>Air Compressor</u>: check for looseness.</li> </ul>	
<ul style="list-style-type: none"> <li>• <u>Check for Leaks</u>: look for oil, coolant, power steering and brake fluid as possible leaks. Check for fluid leaks around the brake master cylinder, exhaust pipes, valve covers or the radiator and hoses.</li> </ul>	
<ul style="list-style-type: none"> <li>• <u>Brake Master Cylinder</u>: check brake fluid.</li> </ul>	
<ul style="list-style-type: none"> <li>• <u>Check Belts</u>: look for frayed, cracked or worn spots on belts.</li> </ul>	
<b>B. CHECK INSIDE BUS – Start Engine</b>	
<b>1. Check Operation Of:</b>	
<ul style="list-style-type: none"> <li>• <u>Oil Pressure Gauge</u>: for building oil pressure. Oil pressure should come up to normal within seconds after the engine is started. If no gauge, identify the location of the warning light that indicates a system failure.</li> </ul>	
<ul style="list-style-type: none"> <li>• <u>Alternator Voltmeter</u>: for proper voltage – 12- to 14-volts.</li> </ul>	
<ul style="list-style-type: none"> <li>• <u>Air Pressure Gauges</u>: for building pressure.</li> </ul>	
<ul style="list-style-type: none"> <li>• <u>Steering</u>: for excess free-play. Turn the steering wheel in both directions for no more than 2-inches of free-play.</li> </ul>	
<ul style="list-style-type: none"> <li>• <u>Parking Brake</u>: for adjustment. Set parking brake, step on the brake pedal, place transmission in gear and slowly release brake pedal and see if the bus moves forward.</li> </ul>	
<ul style="list-style-type: none"> <li>• <u>Windshield &amp; Mirrors</u>: look for cracks, fog areas and appropriate adjustment (mirrors only).</li> </ul>	
<ul style="list-style-type: none"> <li>• <u>Windshield Wipers &amp; Washers</u>: for proper operation. Check the condition of the blades.</li> </ul>	
<ul style="list-style-type: none"> <li>• <u>Dash Indicator Lights &amp; Warning Lights</u>: for operation of signal, head, dash, interior and traffic warning lights indicators.</li> </ul>	
<ul style="list-style-type: none"> <li>• <u>Horn(s)</u>: for proper operation.</li> </ul>	
<ul style="list-style-type: none"> <li>• <u>Heaters &amp; Defrosters</u>: for proper operation.</li> </ul>	
<ul style="list-style-type: none"> <li>• <u>Air Brakes</u>: for proper operation. Build air pressure to 120-lbs; Turn engine off-check to see if pressure does not drop more than 2-lbs. within 1-minute; Turn ignition key on, apply the brakes and hold steady pressure and see if air pressure does not drop more than 3-lbs. in 1-minute; Begin pumping the brake pedal to decrease air pressure-at approx. 60-lbs. of pressure, the warning light and alarm buzzer should activate; Continuing pumping the brake pedal until air pressure drops below approx. 40-lbs. and the emergency/parking brake switch pop on. <b>IF ANY OF THESE STEPS FAIL, DO NOT USE THE BUS-CONTACT YOUR SUPERVISOR.</b></li> </ul>	

## DESCRIPTION OF STEP-BY-STEP BUS DAILY PRE-TRIP INSPECTION (Page 2)

<b>C. CHECK LIGHTS ON OUTSIDE OF BUS</b>	
<ul style="list-style-type: none"> <li>• Turn on headlights, clearance, 4-way hazard, and traffic warning lights.</li> <li>• Exit bus with engine idling, transmission in neutral and park/emergency brake set.</li> </ul>	
<b>D. RIGHT FRONT WHEEL (Entrance Door Side)</b>	
<b>1. Check For:</b>	
<ul style="list-style-type: none"> <li>• <u>Hub Oil Seal</u>: grease/oil leaking from seal. Look for bolts missing.</li> <li>• <u>Lug Nuts</u>: missing or loose lug nuts. Look for rust around the lug nuts.</li> <li>• <u>Rim</u>: cracks, indentations or welds.</li> <li>• <u>Tire</u>: cuts, wear bars, knots or any other imperfections in the tire. Tread depth must be a minimum of 4/32-inch (1/8-inch) in the major groove of the tire.</li> <li>• <u>Spring and Mounts</u>: broken spring leaves; look at U-bolts and spring hangers for cracks, looseness or missing cotter keys.</li> <li>• <u>Shock Absorber(s)</u>: oil running from the shock absorber or wet area on bottom and missing bolts.</li> <li>• <u>Air Brake Slack Adjuster</u>: missing cotter keys on the pins. Look and see that the adjuster is set at 90° (all adjusters must be at the same angle at all wheels).</li> <li>• <u>Air Brake Chamber</u>: loose or missing bolts. Check for rust around the chamber.</li> <li>• <u>Brake Hoses</u>: frayed, cracked or rubbing hoses. Check for wet or shiny areas on hoses and/or hose fittings.</li> <li>• <u>Drum or Rotor</u>: cracks or missing pieces.</li> </ul>	
<b>E. FRONT OF BUS</b>	
<b>1. Check For:</b>	
<ul style="list-style-type: none"> <li>• <u>Mirror at Entrance Door</u>: broken brackets or missing bolts; shake and see if it is loose.</li> <li>• <u>Lights</u>: proper operation of headlights, 4-way hazard, clearance and traffic warning lights; check for cracked or missing light covers.</li> <li>• <u>Crossing Arm</u>: proper operation and in the extended position.</li> <li>• <u>Crossing Mirrors</u>: broken brackets or missing bolts; shake and see if they are loose.</li> <li>• <u>Stop Sign(s)</u>: proper operation and in the extended position; check the operation of the flashing lights.</li> </ul>	
<b>F. LEFT FRONT WHEEL/AREA (Driver Side)</b>	
<b>1. Check For:</b>	
<ul style="list-style-type: none"> <li>• <u>Hub Oil Seal</u>: grease/oil leaking from seal. Look for bolts missing.</li> <li>• <u>Lug Nuts</u>: missing or loose lug nuts. Look for rust around the lug nuts.</li> <li>• <u>Rim</u>: cracks, indentations or welds.</li> <li>• <u>Tire</u>: cuts, wear bars, knots or any other imperfections in the tire. Tread depth must be a minimum of 4/32-inch (1/8-inch) in the major groove of the tire.</li> <li>• <u>Spring and Mounts</u>: broken spring leaves; look at U-bolts and spring hangers for cracks, looseness or missing cotter keys.</li> <li>• <u>Shock Absorber(s)</u>: oil running from the shock absorber or wet area on bottom and missing bolts.</li> <li>• <u>Air Brake Slack Adjuster</u>: missing cotter keys on the pins. Look and see that the adjuster is set at 90° (all adjusters must be at the same angle at all wheels).</li> <li>• <u>Air Brake Chamber</u>: loose or missing bolts. Check for rust around the chamber.</li> </ul>	

**DESCRIPTION OF STEP-BY-STEP BUS DAILY PRE-TRIP INSPECTION (Page 3)**

<ul style="list-style-type: none"> <li>• <u>Brake Hoses</u>: frayed, cracked or rubbing hoses. Check for wet or shiny areas on hoses and/or hose fittings.</li> </ul>	
<ul style="list-style-type: none"> <li>• <u>Drum or Rotor</u>: cracks or missing pieces.</li> </ul>	
<ul style="list-style-type: none"> <li>• <u>Steering Box</u>: fluid leaks, missing and/or loose mounting bolts, torn or frayed hoses cracks and non-factory welds.</li> </ul>	
<ul style="list-style-type: none"> <li>• <u>Steering Linkage</u>: steering column, pitman arm and drag link for missing nuts, bolts, cotter keys; check for bent, loose or broken parts.</li> </ul>	
<b>G. UNDER BUS (Driver Side)</b>	
<b>1. Check For:</b>	
<ul style="list-style-type: none"> <li>• <u>Drive Shaft</u>: all U-shaped safety guard brackets are in place and not loose; missing or loose bolts, cracks and non-factory welds.</li> </ul>	
<ul style="list-style-type: none"> <li>• <u>Exhaust System</u>: leaks-listen for and/or smell fumes; look for black soot around connections.</li> </ul>	
<ul style="list-style-type: none"> <li>• <u>Frame</u>: cracks, which may resemble rust lines.</li> </ul>	
<b>H. LEFT REAR WHEELS (Driver Side)</b>	
<b>1. Check For:</b>	
<ul style="list-style-type: none"> <li>• <u>Hub Oil Seal</u>: grease/oil leaking from seal. Look for bolts missing.</li> </ul>	
<ul style="list-style-type: none"> <li>• <u>Lug Nuts</u>: missing or loose lug nuts. Look for rust around the lug nuts.</li> </ul>	
<ul style="list-style-type: none"> <li>• <u>Rim</u>: cracks, indentations or welds.</li> </ul>	
<ul style="list-style-type: none"> <li>• <u>Tire</u>: cuts, wear bars, knots or any other imperfections in the tire. Tread depth must be a minimum of 2/32-inch in the major groove of the tire.</li> </ul>	
<ul style="list-style-type: none"> <li>• <u>Spring and Mounts</u>: broken spring leaves; look at U-bolts and spring hangers for cracks, looseness or missing cotter keys.</li> </ul>	
<ul style="list-style-type: none"> <li>• <u>Shock Absorber(s)</u>: oil running from the shock absorber or wet area on bottom or missing bolts.</li> </ul>	
<ul style="list-style-type: none"> <li>• <u>Air Brake Slack Adjuster</u>: missing cotter keys on the pins. Look and see that the adjuster is set at 90° (all adjusters must be at the same angle at all wheels).</li> </ul>	
<ul style="list-style-type: none"> <li>• <u>Air Brake Chamber</u>: loose or missing bolts. Check for rust around the chamber.</li> </ul>	
<ul style="list-style-type: none"> <li>• <u>Brake Hoses</u>: frayed, cracked or rubbing hoses. Check for wet or shiny areas on hoses and/or hose fittings.</li> </ul>	
<ul style="list-style-type: none"> <li>• <u>Drum or Rotor</u>: cracks or missing pieces.</li> </ul>	
<b>I. REAR OF BUS</b>	
<b>1. Check For:</b>	
<ul style="list-style-type: none"> <li>• <u>Lights</u>: proper operation of taillights, rear license plate, 4-way hazard, clearance and traffic warning lights; check for cracked or missing light covers.</li> </ul>	
<ul style="list-style-type: none"> <li>• <u>Reflectors</u>: red on the rear and cracked or broken lens.</li> </ul>	
<ul style="list-style-type: none"> <li>• <u>Exhaust Pipe</u>: look for cracks, indentation or welds and exhaust extends out from underneath the bus.</li> </ul>	
<ul style="list-style-type: none"> <li>• <u>Rear Emergency Door/Exit</u>: unlocked, door latch out works properly, buzzer/alarm and seal.</li> </ul>	
<b>J. RIGHT REAR WHEELS (Entrance Door Side)</b>	
<b>1. Check For:</b>	
<ul style="list-style-type: none"> <li>• <u>Hub Oil Seal</u>: grease/oil leaking from seal. Look for bolts missing.</li> </ul>	
<ul style="list-style-type: none"> <li>• <u>Lug Nuts</u>: missing or loose lug nuts. Look for rust around the lug nuts.</li> </ul>	
<ul style="list-style-type: none"> <li>• <u>Rim</u>: cracks, indentations or welds.</li> </ul>	



## DESCRIPTION OF STEP-BY-STEP BUS DAILY PRE-TRIP INSPECTION (Page 4)

<ul style="list-style-type: none"> <li>• <u>Tire</u>: cuts, wear bars, knots or any other imperfections in the tire. Tread depth must be a minimum of 2/32-inch in the major groove of the tire.</li> </ul>	
<ul style="list-style-type: none"> <li>• <u>Spring and Mounts</u>: broken spring leaves; look at U-bolts and spring hangers for cracks, looseness or missing cotter keys.</li> </ul>	
<ul style="list-style-type: none"> <li>• <u>Shock Absorber(s)</u>: oil running from the shock absorber or wet area on bottom and missing bolts.</li> </ul>	
<ul style="list-style-type: none"> <li>• <u>Air Brake Slack Adjuster</u>: missing cotter keys on the pins. Look and see that the adjuster is set at 90° ( all adjusters must be at the same angle at all wheels).</li> </ul>	
<ul style="list-style-type: none"> <li>• <u>Air Brake Chamber</u>: loose or missing bolts. Check for rust around the chamber.</li> </ul>	
<ul style="list-style-type: none"> <li>• <u>Brake Hoses</u>: frayed, cracked or rubbing hoses. Check for wet or shiny areas on hoses and/or hose fittings.</li> </ul>	
<ul style="list-style-type: none"> <li>• <u>Drum or Rotor</u>: cracks or missing pieces.</li> </ul>	
<b>K. FUEL AREA</b>	
<b>1. Check For:</b>	
<ul style="list-style-type: none"> <li>• <u>Fuel Tank</u>: fuel cap is properly mounted on fuel tank; the gasket on the cap; and loose parts, cracks or missing pieces of the fuel tank safety cage.</li> </ul>	
<ul style="list-style-type: none"> <li>• <u>Fuel Leaks</u>: Be alert to fume smells and look for fuel spills on the ground.</li> </ul>	
<b>L. PASSENGER AREA INSIDE BUS</b>	
<b>1. Check For:</b>	
<ul style="list-style-type: none"> <li>• <u>Entrance Door</u>: broken glass and proper operation (closing and opening).</li> </ul>	
<ul style="list-style-type: none"> <li>• <u>Step Treads</u>: treads securely fastened and not posing a tripping hazard; area open and free of any objects or articles.</li> </ul>	
<ul style="list-style-type: none"> <li>• <u>Handrail(s)</u>: looseness, missing bolts and catch-points.</li> </ul>	
<ul style="list-style-type: none"> <li>• <u>Passenger Seats</u>: loose seats; walk to the back of the bus, grab the back corner of each bottom seat and pull up to see if they are properly attached; check for cuts or torn seat covers.</li> </ul>	
<ul style="list-style-type: none"> <li>• <u>All Emergency Doors &amp; Exits</u>: all doors, windows and roof emergency exits are unlocked; open each to check their alarm buzzer. If equipped with a Folding Seat (at a side emergency door) check for proper fold-up operation.</li> </ul>	
<ul style="list-style-type: none"> <li>• <u>Passenger Seat Backs</u>: loosen or broken frames and/or mounts; check each seat by grabbing the top corner of the seat and shake to see if it is loose or broken.</li> </ul>	
<ul style="list-style-type: none"> <li>• <u>Windows</u>: cracked or broken glass; check for the proper operation of the windows.</li> </ul>	
<ul style="list-style-type: none"> <li>• <u>Emergency Equipment</u>: the proper size and type fire extinguisher is fully charged and properly secured on a bracket; the first aid and body fluids kits are properly mounted and contain required contents; the triangle reflective markers kit contains 3-markers and properly secured; and the web cutter is properly mounted.</li> </ul>	
<b>M. FINAL CHECKS</b>	
<b>1. Check For:</b>	
<ul style="list-style-type: none"> <li>• <u>Brake, Back-Up and Turn Signal Lights</u>: proper operation of the lights. Depress the brake pedal, place the bus in reverse gear and look for the red reflections of the brake lights, the reflections of the back-up lights and listen for the back-up alarm.</li> </ul>	
<ul style="list-style-type: none"> <li>• <u>Clutch &amp; Transmission</u>: start the bus and put the bus in gear, release the clutch and check for proper engagement.</li> </ul>	
<ul style="list-style-type: none"> <li>• <u>Brakes</u>: pull the bus forward and depress the brake pedal to check for proper stopping ability.</li> </ul>	
<ul style="list-style-type: none"> <li>• <u>Steering</u>: operate the steering wheel back and forth to check for proper control.</li> </ul>	

# BUS DRIVER'S DAILY PRE-TRIP INSPECTION REPORT

School Division: \_\_\_\_\_

Bus #: \_\_\_\_\_

Odometer Reading: \_\_\_\_\_

Date: \_\_\_\_\_

INSPECT ALL ITEMS LISTED – IF DEFECTIVE, MARK (“X”) & DESCRIBE IN ‘REMARKS’

<b>CHECK ITEMS BELOW:</b>	<b>X</b>	<b>CHECK ITEMS BELOW:</b>	<b>X</b>
• Fluid Leaks Under Bus	<input type="checkbox"/>	• Cleanliness of Interior & Exterior	<input type="checkbox"/>
• Loose Wires or Hose Connections	<input type="checkbox"/>	• Emergency Doors, Exits & Buzzers	<input type="checkbox"/>
• Belts in Engine Compartment	<input type="checkbox"/>	• Front Traffic Warning Lights	<input type="checkbox"/>
• Oil Level	<input type="checkbox"/>	• Headlights, Signal & 4-Way Lights	<input type="checkbox"/>
• Radiator Coolant Level	<input type="checkbox"/>	• Front of Bus – Windshield	<input type="checkbox"/>
• Power Steering Fluid	<input type="checkbox"/>	• Left Front Tire, Wheel & Rim & Suspension	<input type="checkbox"/>
• Battery	<input type="checkbox"/>	• Stop Arm(s) – Sign(s) & Lights	<input type="checkbox"/>
• Transmission	<input type="checkbox"/>	• Ride Front Tires, Wheels, Rims & Suspension	<input type="checkbox"/>
• Clutch	<input type="checkbox"/>	• Exhaust System	<input type="checkbox"/>
• Unusual Engine Noise	<input type="checkbox"/>	• Left Side of Bus – Windows & Lights	<input type="checkbox"/>
• Gauges & Warning Lights	<input type="checkbox"/>	• Left Rear Tires, Wheels, Rims & Suspension	<input type="checkbox"/>
• Switches	<input type="checkbox"/>	• Rear of Bus – Windows & Lights	<input type="checkbox"/>
• Horn	<input type="checkbox"/>	• Right Rear Tires, Wheels, Rims & Suspension	<input type="checkbox"/>
• Fans & Defrosters	<input type="checkbox"/>	• Right Side of Bus – Windows & Lights	<input type="checkbox"/>
• Wipers & Washers	<input type="checkbox"/>	• Drive Shaft & Guards	<input type="checkbox"/>
• Stop Sign(s) & Crossing Arm Controls	<input type="checkbox"/>	• Lettering & Paint	<input type="checkbox"/>
• All Outside and Inside Mirrors	<input type="checkbox"/>	• Driver's Seat & Belt	<input type="checkbox"/>
• Brake Pedal & Warning Light	<input type="checkbox"/>	• All Seats and Belts	<input type="checkbox"/>
• Controls & Operation of Entrance Door	<input type="checkbox"/>	• Brakes: Parking & Service	<input type="checkbox"/>
• Emergency Equipment	<input type="checkbox"/>	• Steering	<input type="checkbox"/>
• First Aid & Body Fluids Kits	<input type="checkbox"/>	• Wheelchair Lift Controls & Operation	<input type="checkbox"/>
• Entrance Door/Entrance Steps and Handles	<input type="checkbox"/>	• Tie-Downs & Securement Equipment	<input type="checkbox"/>
• Fuel Tank	<input type="checkbox"/>		<input type="checkbox"/>

**DRIVER REMARKS:**

\_\_\_\_\_

\_\_\_\_\_

\_\_\_\_\_

**[If repairs are indicated above, follow local procedures]**

\_\_\_\_\_

Print Driver's Name

\_\_\_\_\_

Driver's Signature

\_\_\_\_\_

Supervisor's Signature & Date

**Monthly Record of Daily Pre-Trip Inspections**

Complete Daily and turn in at the end of the month

Month	Date	1	2	3	4	5	6	7	8	9	10	11	12	13	14	15	16	17	18	19	20	21	22	23	24	25	26	27	28	29	30	31	
<b>A. Front Of Bus</b>																																	
<b>B. Inside The Bus</b>																																	
<b>C. Lights On Outside Of Bus</b>																																	
<b>D. Right Front Wheel</b>																																	
<b>E. Front Of The Bus</b>																																	
<b>F. Left Front Wheel/Area</b>																																	
<b>G. Under Bus</b>																																	
<b>H. Left Rear Wheel</b>																																	
<b>I. Rear of Bus</b>																																	
<b>J. Right Rear Wheel</b>																																	
<b>K. Fuel Area</b>																																	
<b>L. Passenger Area Inside Bus</b>																																	
<b>M. Final Checks</b>																																	
<b>Driver's Initials</b>																																	
<b>Bus Number</b>																																	

## SECTION II

### INSPECTION SCHEDULES AND GUIDELINES

The purpose of this section is to assist personnel who are responsible for the maintenance of school buses by providing schedules, checklists, and guidelines governing inspections.

The Inspection Checklist is used for inspections performed at the times indicated in the manual. Such inspections are required by the Board of Education as stated in the *Regulations Governing Pupil Transportation*.

#### **8VAC 20-70-130. Maintenance inspection.**

"All school buses and school activity buses used to transport public school pupils to and from school and school activity events shall be inspected and maintained by competent mechanics at least once every 45 school days, with "school days" as determined by the school division's approved yearly calendar or modifications in the calendar as approved by the division superintendent or designee, or every 5,000 miles. Any bus that is removed from service or deadlined so as to disrupt the scheduled maintenance shall be inspected prior to being returned to service. At no point shall any bus go without an inspection during the school semester and such inspections shall be no more than 90 days apart excluding summer sessions. The inspections and maintenance shall be conducted in accordance with provisions of the Preventive Maintenance Manual for Virginia School Buses, and recorded on the prescribed inspection forms or in a format approved by the Department of Education. Additional Original Equipment Manufacturer (OEM) inspection and maintenance recommendations should be maintained during the service life of each bus to ensure safety and warranty requirements are met. Maintenance consideration should be given to buses operated during the summer session. If the inspection and maintenance are not made in a shop operated by the school board or the local governing body, the school board shall designate one or more inspection centers to make the inspections and require a copy of the results of the inspections to be furnished to the division superintendent. School division compliance with the foregoing maintenance inspection requirements shall be subject to verification by the Department of Education.

Guidelines for inspection include recommended "Out-of-Service" criteria that should be used as a best practice and minimum standard of inspection as outlined in Annual Motor Vehicle Inspection Manual of the Virginia State Police (19 VAC30-70-1). In any instance where the inspection outlined in this manual appears

to be less than those standards as outlined by the Virginia State Police inspection manual, the standards of the Virginia State Police should take precedent.

Completion of the Inspection form requires that conditions be recorded as follows:

(/)= "OK" no defects with the vehicle and it is safe to operate.

(M)= "Repair made" defects that were able to be corrected during the inspection. Recording of this category allows inspectors to see if there is a trend of defects on particular vehicles or vehicle operation.

(N)= "Repair needed" defects that could not be immediately corrected but does not affect the safe operation of the vehicle and does not create an "Out-of-Service" condition.

(O)= "Out-of-Service" defects which could affect the safe operation of the vehicle. Vehicles placed in an "Out-Of Service" status must not be allowed to operate until appropriate repairs have been made to correct the defect.

Items outlined in this manual are not all inclusive and may not include all safety items applicable to a particular vehicle.

**VIRGINIA DEPARTMENT OF EDUCATION**

BUS INSPECTION: EVERY 45 SCHOOL DAYS OR 5000 MILES

DATE \_\_\_\_\_ MILEAGE \_\_\_\_\_ BUS # \_\_\_\_\_ VIN # \_\_\_\_\_

INDICATE THE CONDITION OF EACH ITEM IN THE SPACE PROVIDED WITH THE FOLLOWING:  
 ( / ) = OK    (A) = ADJUSTMENT MADE    (X) = REPAIR MADE    (N) = REPAIR NEEDED

<b>A. ROAD TEST</b>	<b>C. EXTERIOR</b>	<b>E. FRONT AXLE</b>
STARTER ACTION	BODY DAMAGE	FLUID LEAKS
ENGINE OPERATION	HOOD AND FENDERS	STEERING LINKAGE
OIL PRESSURE	STIRRUP STEPS	SHOCK ABSORBERS
HORNS	LICENSE PLATES	BRAKE LINING
LIGHTS-WARNING /BUZZERS	TOW HOOKS	SLACK ADJUSTERS
CLUTCH	BUMPERS	SPRINGS
STEERING	ALL TIRES AND WHEELS	KING PINS & BUSHINGS
TRANSMISSION	ALL LIGHTS & SIGNALS	WHEEL CYLINDER/CALIBER
BACK-UP ALARM	REFELCTORS	HUB, DRUMS, ROTORS
BRAKE CHECK	RETROREFLECTIVE TAPE	WHEEL BEARINGS
INSTRUMENTATION	PAINT AND LETTERING	WHEEL BALANCE
MIRRORS	MIRRORS	ALIGNMENT
HEATER/DEFROSTER	STORAGE & CHAIN BOXES	<b>F. REAR AXLE</b>
WINDSHIELD WIPERS	<b>D. ENGINE COMPARTMENT</b>	FLUID LEAKS
WINDSHIELD WASHERS	ALL BELTS	AXLE VENTS
STOP ARM/XING GUARD	LEAKS	SHOCK ABSORBERS
GOVERNOR	GOVERNOR(S)	BRAKE LINING
<b>B. BODY INTERIOR</b>	FAN ASSEMBLY	SLACK ADJUSTERS
AISLE AND FLOOR	WATER PUMP	SPRINGS
INTERIOR PANELS	AIR COMPRESSOR	KING PINS & BUSHINGS
ENTRANCE DOOR	ALL PIPING & HOSES	WHEEL CYLINDER/CALIBER
EMERGENCY DOOR & EXITS	ALL WIRING	HUB, DRUMS, ROTORS
EMERGENCY EQUIPMENT	STEERING GEAR	WHEEL BEARINGS
DRIVER'S SEAT	HYDRALIC PUMP	WHEEL BALANCE
STEPS	MASTER CYLINDER	WHEEL SEALS
PASSENGER SEATS & BELTS	BRAKE BOOSTER	<b>G. UNDER BUS</b>
STANCHIONS /BARRIERS	RADIATOR MOUNTING	EXHAUST SYSTEM
SUNSHIELD/VISOR	FUEL SYSTEM	CLUTCH
ALL GLASS / WINDOWS	BATTERY(S)	AIR TANKS
LIFT OR RAMP	CRANKCASE VENT VALVE	TRANSMISSION
WHEELCHAIR POSITIONS	TURBOCHARGER	PARKING BRAKE
RADIOS AND CAMERAS	VIBRATION DAMPER	DRIVE LINE
INTERIOR WIRING	ENGINE MOUNTS	FUEL TANK & FUEL LINES
ALL OPENINGS	COOLING SYSTEM	HOSE-PIPING-WIRING
STORAGE COMPARTMENTS		AIR DRYER
POSTERS AND STICKERS		BRAKE CHAMBERS
LOOSE OBJECTS & CLEANLINESS		FRAME & CROSSMEMBER
HANDRAILS		
	<b>Comments:</b>	

MECHANIC or INSPECTOR \_\_\_\_\_ DATE COMPLETED \_\_\_\_\_

**A. Road Test**

Inspection Procedures:			Repair if:	Recommended Out of Service if:
<p><b>1. Starter Action.</b></p> <p>a. Check whether starter turns engine at normal speed.</p> <p>b. Check for snappy action, noise and operation of starter drive.</p>				<p>Engine will not start or is difficult to start.</p>
<p><b>2. Engine Operation.</b></p> <p>a. Check for unusual noise or vibration at all engine speeds.</p> <p>b. Check for rough idling and misfiring.</p>			<p>Rough or low idle.</p>	<p>Engine will not shut down.</p> <p>There is hesitation upon acceleration.</p> <p>Engine stalls or is misfiring.</p>

**A. Road Test**

Inspection Procedures:			Repair if:	Recommended Out of Service if:
<p><b>2. Engine Operation.</b></p> <p>c. Check for bearing noises, piston slap and knocks.</p> <p>d. Check color of exhaust.</p> <p>e. Check operation of glow plugs and engine shut down.</p>				<p>Acceleration performance is poor.</p>
<p><b>3. Oil Pressure.</b></p> <p>a. Check pressure at idle and governed speed.</p>			<p>Oil pressure gauge is inaccurate, damaged or difficult to read.</p>	<p>Gauge does not function or is unreadable. Oil pressure gauge or tube leaks.</p>



**A. Road Test**

Inspection Procedures:		Repair if:	Recommended Out of Service if:
<p><b>4. Horn</b></p> <p>a. Check for proper operation.</p>			<p>Horn not in good working order.</p>
<p><b>5. Warning lights/Buzzers.</b></p> <p>a. Check all instrument lights for proper illumination of instruments.</p> <p>b. Check all warning and indicator lights.</p> <p>c. Check interior courtesy light.</p>		<p>Light bulb for the following gauge or control is inoperative:</p> <ol style="list-style-type: none"> <li>1) Oil pressure</li> <li>2) Temperature</li> <li>3) Fuel</li> <li>4) Voltmeter</li> </ol>	<p>Light bulb for the following gauge or control is inoperative:</p> <ol style="list-style-type: none"> <li>1) Low air pressure or vacuum.</li> <li>2) High Beam.</li> <li>3) Left or right turn signal or 4-way hazard.</li> </ol>

**A. Road Test**

Inspection Procedures:			Repair if:	Recommended Out of Service if:
<p><b>5. Warning Lights/Buzzers.</b></p>			<p>5) Ammeter 6) Engine shutdown 7) Strobe light</p> <p>One or more lights for control switches are inoperative.</p>	<p>All dash or control panel lights are inoperative.</p> <p>Speedometer light is inoperative.</p> <p>Shift indicator light is inoperative.</p>
<p>d. Check for presence and operations of the following warning lights and buzzers or indicators.</p> <p>1) High coolant temperature and dash warning light, buzzer or bell.</p> <p>Low oil pressure dash warning light, buzzer or indicators.</p>				<p>High water temperature dash warning light, buzzer or indicators is inoperative.</p> <p>Low oil pressure dash warning light, buzzer or indicators is inoperative.</p>

**A. Road Test**

Inspection Procedures:			Repair if:	Recommended Out of Service if:
<p><b>6. Clutch</b></p> <p>a. Check for proper free travel and operation.</p>			<p>Clutch engagement is rough or noisy.</p> <p>Clutch pedal travel has less than one inch.</p>	<p>Clutch does not engage or is slipping.</p> <p>Clutch pedal clearance is in excess of 1 ½ inches or manufacturer's specification.</p>
<p><b>7. Steering</b></p> <p>A. Free play</p> <p>1) Check for excessive free play.</p>				<p>There is excessive wandering or shimmy due to free play in the steering (see steering wheel lash chart).</p> <p>Steering is unusually tight or binding when turning right or left.</p>

**A. Road Test**

Inspection Procedures:			Repair if:	Recommended Out of Service if:
<p><b>7. Steering</b></p> <p>B. Wheel</p> <p>1) Visually inspect the condition of the wheel.</p>			<p>Steering wheel plastic cracked.</p>	<p>Steering wheel loose on column.</p> <p>Steering wheel non O.E.M design.</p> <p>Plastic missing so that metal steering wheel reinforcement is exposed.</p>
<p>C. Column</p> <p>1) Check the column in the bus for up and down movement, side to side movement and proper mounting.</p>			<p>Rubber boot at bulkhead (if equipped) is torn or missing.</p>	<p>Side to side movement exceeds ¼-inch or up and down movement exceeds 1-inch.</p> <p>Columns mount assembly mounting (including floor mounting plate) or fasteners loose.</p>
<p>2) Check for operation of tilt and telescoping function if equipped.</p>			<p>Does not tilt or telescope.</p>	<p>Does not latch securely in place.</p>

## 7. Steering Chart

### Steering wheel play (lash) Measurements

Lash shall not exceed the following measurements.

Steering Wheel Size	Play(Lash) Manual Steering	Play (Lash) Power Steering
16 inches or less	2 inches	4 $\frac{1}{2}$ inches
18 inches	2 $\frac{1}{4}$ inches	4 $\frac{3}{4}$ inches
20 inches	2 $\frac{1}{2}$ inches	5 $\frac{1}{4}$ inches
22 inches	2 $\frac{3}{4}$ inches	5 $\frac{3}{4}$ inches

**A. Road Test**

Inspection Procedures:		Repair if:	Recommended Out of Service if:
<p><b>8. Transmission</b></p> <p>a. Check for proper operation by shifting through shift pattern.</p>		<p>Does not shift easily into all gears.</p>	<p>Will not shift into all gears.</p> <p>Indicates wrong gear (Touch pad).</p> <p>LED's out and/or can't tell which gear the transmission is in.</p> <p>Detent is non-functional.</p> <p>Knob or handle missing from the end of shifter.</p> <p>There is excessive rough up or down shifting or hard shifts.</p> <p>Transmission will not shift up or down through gear range.</p> <p>Transmission is slipping or noisy.</p> <p>Shift points are not within manufacturer's specification.</p>

**A. Road Test**

Inspection Procedures:			Repair if:	Recommended Out of Service if:
<p><b>9. Backup Alarm.</b></p> <p>Check for presence of back up alarm (buses manufactured starting November 1990) and dash sticker (starting November 1993). Check operation of alarm by placing transmission in reverse (engine running) and listening for alarm sound.</p>			<p>Dash sticker is not mounted on dash in plain view of the driver.</p> <p>Dash sticker is not present (starting November 1993).</p>	<p>Backup alarm does not sound.</p>
<p><b>10. Brake Check.</b></p> <p>A. AIR</p> <p>1) Chock wheels if necessary and push in parking brake knob.</p> <p>Start engine.</p> <p>2) Air pressure build up from 50 to 90 psi should not exceed 5 min. at first engine idle.</p>			<p>Brake pedal pad is loose or worn through or worn smooth in any area.</p>	<p>Brake pedal pad is missing (if originally equipped) or worn out. Pedal is equipped with any "extender" block.</p>

**A. Road Test**

Inspection Procedures:			Repair if:	Recommended Out of Service if:
<p><b>10. Brake Check.</b> Compressor governor cut out pressure should be reached at approximately 120--psi.  Shut off engine and turn key back on.</p>				
<p>With brakes in the released position, check for air pressure leak (pressure drop) for at least 1-minute.</p>				
<p>Firmly depress brake pedal and do not release. Check for air pressure leak (pressure drop) for at least 1-minute. Air leakage should not exceed 3 psi per minute.</p>			<p>Air leaks, but rate is less than 2 psi per minute (brakes released) or 3 psi per minute (with service brakes applied).</p>	<p>Air pressure leaks more than 2 psi per minute, (brakes not applied), or more than 3 psi per minute (with service brake applied).</p>



**A. Road Test**

Inspection Procedures:			Repair if:	Recommended Out of Service if:
<p><b>10. Brake Check.</b></p> <p>Step on and off brake pedal to decrease air pressure-warning light and buzzer should activate at about 60 psi.</p> <p>Continue to decrease air pressure-parking brake knob should pop out between 20- and 45 psi.</p> <p>Restart engine, shift into lo gear and gently pull against brakes to make sure they will hold.</p>				

**A. Road Test**

Inspection Procedures:		Repair if:	Recommended Out of Service if:
<p><b>10. Brake Check.</b></p> <p>Set hand brake (Orschlein)-must cam over center (adjust if necessary).</p> <p>With park brake set, engage transmission and gently pull against brake to check holding ability.</p>			<p>Vehicle moves when parking brake applied.</p>
<p><b>11. Instrumentation</b></p> <p>Check for proper operation of all instruments.</p> <p>A. Check from driver's position the visibility, O.E.M. location, readability, operation, accuracy, and condition of the following gauges:</p> <p>1) Speedometer and odometer.                  2 Oil pressure.                  3) Temperature.</p>		<p>Oil pressure, temperature, fuel, voltmeter or ammeter gauge is inaccurate, damaged or difficult to read.</p> <p>Odometer doesn't work or is not working properly.</p> <p>Odometer is unreadable.</p>	<p>Oil or temperature gauge does not function or is unreadable.</p> <p>Speedometer is unreadable, is confirmed to be inaccurate or doesn't work.</p>

**A. Road Test**

Inspection Procedures:		Repair if:	Recommended Out of Service if:
<p><b>11. Instrumentation</b></p> <p>4) Fuel. 5) Voltmeter or ammeter (voltmeter only required starting September 1985). 6) Air pressure or vacuum.</p>			<p>Air pressure or vacuum gauge(s) are inaccurate, unreadable, or not working. Air pressure gauge must read within plus or minus seven 7psi. (single gauge) at 100 psi.</p>
<p>B. Check for presence and operation of the following indicators:</p> <p>1) Air pressure or vacuum gauge or warning light. 2) High beam light. 3) Left and right turn signal and 4-way hazard. 4) Check all dash and control panel lights for illumination at gauges and switches.</p>		<p>Not equipped with voltmeter for bus purchased starting September 1985</p> <p>Illumination for the following gauge or control is inoperative:</p> <p>1) Oil pressure 2) Temperature 3) Fuel 4) Voltmeter 5) Ammeter 6) Engine Shutdown (Bowden Cable) 7) Strobe light</p>	<p>Illumination for the following gauge or control is inoperative:</p> <p>1) Air pressure or vacuum. 2) High beam. 3) Left or right turn signal or 4-way hazard.</p> <p>All dash or control panel lights are inoperative.</p> <p>Shift Indicator light is inoperative.</p> <p>Any gauge missing or cannot be read.</p>

**A. Road Test**

Inspection Procedures:			Repair if:	Recommended Out of Service if:
<p><b>12. Mirrors</b></p> <p><b>a. Rearview</b> Check all mirrors for clear visibility.</p> <p>Check exterior rearview mirrors specifications, condition, mounting, and adjustment.</p>				<p>Any exterior rearview mirror is broken, cracked, or loose in frame.</p> <p>Either mirror does not give driver a clear view down to lower outside edge of rear tire at ground level, on both sides to the rear.</p> <p>Any bracket is broken or mirror mounting is insecure.</p> <p>Reflective surface is deteriorated.</p> <p>Any mirror does not meet applicable specification.</p>
<p><b>b. Convex</b> Check convex crosswalk and side-view mirrors for specifications (correct type, size, and location) condition, mounting, and adjustment.</p>				<p>Required convex mirrors are not present.</p> <p>Any mirror is cracked, broken, or loose in frame.</p>

**A. Road Test**

Inspection Procedures:			Repair if:	Recommended Out of Service if:
<p><b>12. Mirrors</b></p>				<p>Any mirror is out of adjustment.</p> <p>Any mirror reflective surface is deteriorated.</p> <p>Any portion of mirror mounting system is loose or broken.</p> <p>Mirrors do not meet specifications.</p> <p>"No blind-spot" mirror system meeting new performance specifications start November 1990 (e.g., Bus Boy-type).</p> <p>Mirrors do not give driver a clear view of the area around the front of the bus.</p>
<p><b>c. Interior</b></p> <p>Check interior rearview mirror for size, condition, and mounting.</p>				<p>Interior rearview mirror is not at least 6" x 30" (except Type A shall be 6" x 16").</p> <p>Mirror does not have rounded corners and protected edges.</p>

**A. Road Test**

Inspection Procedures:		Repair if:	Recommended Out of Service if:
<p><b>12. Mirrors</b></p>			<p>Any portion of reflective surface is obstructed by stickers or other items or is deteriorated.</p> <p>Driver's view of images in mirror is not clear due to distortion or other causes.</p> <p>Mirror mounting is loose.</p>
<p><b>13. Heaters &amp; Defrosters.</b></p> <p><b>a. Heaters</b></p> <p>Check for proper operation.</p> <p>Inspect heater system for:</p> <p>1) Heating performance and water control valve (interior).</p> <p>2) Blower operation, condition, and control switches.</p>		<p>Not producing adequate heat (including any auxiliary heat)</p> <p>Water control valve hard to operate.</p> <p>Heater blowers do not work on all speeds, are noisy, or vibrate.</p>	<p>Heater cores, hoses, or valve leaks (including any auxiliary heater).</p> <p>Heater hoses are cracked, swollen, or badly chafed.</p> <p>Shielding is missing (starting November 1980) or does not completely cover hoses.</p>

<b>A. Road Test</b>
---------------------

Inspection Procedures:		Repair if:	Recommended Out of Service if:
<p><b>13. Heaters &amp; Defrosters.</b></p> <p>3) System leakage, condition, and hose shielding (shielding required starting November 1980).</p> <p>4) Condition of ductwork and heater box.</p>		<p>Blower switches are damaged, loose, or blower operates intermittently.</p> <p>Heater ductwork or heater box components are missing, damaged, loose, or obstructed.</p>	<p>Any portion of heating system within passenger area creates sharp edges, projections, or other hazards to passengers.</p>
<p><b>b. Defrosters</b></p> <p>Inspect windshield defroster system for:</p> <p>1) Airflow, heat, and coverage area.</p> <p>2) Blower operation, condition, and control switches.</p> <p>3) Condition of ductwork, diffusers, and fresh air control (if equipped).</p>		<p>Any defroster blower does not work on low speed, is noisy, or vibrates.</p> <p>Blower switches are damaged or loose.</p> <p>Any ductwork or diffusers are loose or damaged.</p> <p>Fresh air control (if equipped) does not function.</p>	<p>Airflow is not present at all defroster outlets.</p> <p>Any defroster blower does not work on high speed.</p>

**A. Road Test**

Inspection Procedures:			Repair if:	Recommended Out of Service if:
<p><b>14. Windshield Wipers.</b></p> <p><b>a. Operation</b></p> <p>Check for proper operation.</p> <p>Inspect both wipers for:</p> <p>1) Swept area field of view and effectiveness of wiping.</p> <p>2) Proper operation of both wipers on high and low speeds and condition and mounting of switch(es) and knob(s).</p>			<p>Either wiper does not operate on low speed.</p> <p>Wiper goes past perimeter of glass.</p>	<p>Either wiper does not effectively clear driver's field of vision.</p> <p>Switch(es) mounting loose or knob(s) missing or loose.</p>
<p>3) Condition and mounting of wiper motors and linkage.</p>				<p>Either wiper motor or linkage is visibly damaged or loose.</p>



**A. Road Test**

Inspection Procedures:			Repair if:	Recommended Out of Service if:
<p><b>14. Windshield Wipers.</b></p> <p><b>b. Park</b></p> <p>Inspect for parked position of wipers when turned off (electric) or when manually parked (air).</p>				<p>Electric wipers do not automatically return to parked position out of driver's line of sight when turned off.</p> <p>Air wipers cannot be manually parked out of driver's line of sight using control switch.</p>
<p><b>c. Blades</b></p> <p>Inspect blades for condition, mounting, and tension.</p>			<p>Poor cleaning of windshield.</p>	<p>Either blade is damaged, deteriorated, loose, or does not hold proper tension against windshield.</p>
<p><b>15. Windshield Washers.</b></p> <p>1) Check for proper operation.</p>			<p>Washer does not operate or is misadjusted.</p>	

**A. Road Test**

Inspection Procedures:			Repair if:	Recommended Out of Service if:
<p><b>16. Stop Arm &amp; Crossing Guard.</b></p> <p><b>a. Stop arm.</b></p> <p>Check stop arm(s) for specifications and operation fully extends to 90° (degrees).</p>			<p>Wiring-ground strap is loose or not properly routed and secured.</p> <p>Hinge or bushing(s) is dry of lubrication.</p> <p>Stop arm assembly or blade mounting is loose.</p>	<p>Wires or ground strap(s) is broken.</p> <p>Any stop arm light does not flash or does not flash between 60 and 120 times per minute.</p> <p>Stop arm does not fully extend or retracts slowly.</p>
<p><b>b. Crossing Arm.</b></p> <p>Check for proper operation by cycling through warning lights, entrance door opening.</p> <p>Check front bumper mounted student crossing arm for operation, condition, and mounting.</p>				<p>Not equipped with student crossing arm, starting January 1990.</p> <p>Does not fully extend 90° (degrees) from bumper.</p> <p>Does not deploy when stop arm switch is activated.</p>

**A. Road Test**

Inspection Procedures:		Repair if:	Recommended Out of Service if:
<p><b>16. Stop Arm &amp; Crossing Guard.</b></p>		<p>Stop arm extends more or less than 90° (degrees).</p> <p>Any lenses cracked and no white light is visible.</p>	<p>Any stop arm has an air or vacuum leak.</p> <p>Any stop arm (paint or decal) is significantly faded or discolored.</p>
<p><b>17. Road Speed Governor/ECM/Electronic speed limiter.</b></p> <p>Check for proper operation. (Maximum Speed allowable by § 46.2-871).</p>			<p>Exceeds max allowable speed of § 46.2-871.</p>

**B. Body Interior**

Inspection Procedures:			Repair if:	Recommended Out of Service if:
<p><b>1. Aisle &amp; Floor.</b></p> <p>1) Check condition of aisle and floor covering.</p> <p>2) Inspect floor covering, plywood sub-floor (if installed), aisle, and cove molding strips for condition, adhesion and/or fastening holes or cracks, and ribbed rubber on aisle.</p>			<p>Rubber floor covering is loose, deteriorated, or cracked.</p> <p>Plywood is rotten or soft.</p> <p>Cove molding is loose or fasteners are missing.</p>	<p>There are any unsealed holes or cracks through to underside of bus.</p> <p>Aisle is not equipped with 12-inch wide ribbed rubber.</p> <p>Any aisle molding strip is not securely fastened to floor or any aisle or cove molding presents a sharp edge or protrusion.</p> <p>There is any damage to rubber floor covering which could cause a tripping hazard.</p>
<p><b>2. Interior Panels.</b></p> <p>1) Check for sharp edges and damage.</p>				

**B. Body Interior**

Inspection Procedures:			Repair if:	Recommended Out of Service if:
<p><b>2. Interior Panels.</b></p> <p>2) Check all interior sidewall, rear, ceiling, and driver's area paneling for secure fastening, projections or sharp edges, and condition.</p>			<p>There are loose or missing attachment screws on any light bar panel or other maintenance access panel.</p> <p>Interior paneling is mildewed, or paint (where required) is missing or damaged.</p>	<p>Sharp edges, rust-through, or projections from paneling which could cause injury to passengers or driver.</p> <p>Any missing paneling.</p>
<p><b>3. Entrance Door.</b></p> <p><b>a. Operation</b></p> <p>Check service door assembly for operations, adjustment, condition, mounting and fit.</p>			<p>Door does not seal properly or seals are damaged, ripped, or deteriorated.</p> <p>3- to 6- inch crack in glass.</p>	<p>Door jams, binds, or is difficult to close or open (a minimum 24") or requires more than 25- lbs. of effort to open or close door.</p> <p>Glass has been replaced with plexiglass, is broken, or is cracked.</p>

**B. Body Interior**

Inspection Procedures:			Repair if:	Recommended Out of Service if:
<p><b>3. Entrance Door.</b></p>				<p>Door glass is fogged more than one 1-inch in from border, or visibility through glass is poor.</p> <p>Door is equipped with any hasp or lock except factory approved system.</p> <p>Door assembly is damaged, or mounting is loose.</p> <p>Door seals are not present.</p>
<p><b>b. Control</b></p> <p>1) Check manual service door control and rod assembly for over-center or latching device condition, mounting and operation.</p>			<p>Control, rod hardware, or mounting is loose.</p> <p>Door control doesn't operate freely.</p>	<p>Door will not open or close completely.</p> <p>Manual control will not lock over-center, or latching mechanism is inoperative.</p> <p>Door control requires excessive force to operate.</p>

**B. Body Interior**

Inspection Procedures:			Repair if:	Recommended Out of Service if:
<p><b>3. Entrance Door.</b></p> <p>2) Check air or vacuum powered service door control assembly for leaks, operation, insecure door in closed position, and emergency release.</p>			<p>Air or vacuum powered system leaks or does not operate properly.</p>	<p>Air or vacuum door emergency release does not function, or control is broken.</p> <p>Air or vacuum door opens or closes at an excessive rate or opens too slowly.</p>
<p><b>c. Overhead Pad.</b></p> <p>Check bus for pad that is a minimum three (3) inches wide, high density foam rubber padded safety cushion, mounted directly above the inside of the service door.</p>			<p>Pad is loose, or cover has minor rip(s).</p>	<p>Pad is missing or cover is severely ripped, exposing foam.</p>
<p><b>4. Emergency Doors &amp; Exits.</b></p> <p><b>a. Operation</b></p> <p>Inspect for operation and condition of rear emergency door and side.</p>			<p>Rear door opens too far, damaging lights.</p>	

**B. Body Interior**

Inspection Procedures:		Repair if:	Recommended Out of Service if:
<p><b>4. Emergency Doors &amp; Exits.</b></p> <p>(buses built after November 1993), door latch, door hold open feature, door seal, emergency windows, and emergency exits/ventilator (roof hatches).</p>		<p>Any exit handle, latch, or mounting hardware is loose or missing.</p> <p>Mounting of guard for inside rear door handle is loose.</p> <p>Hold open device (if equipped) is non-operational, bent, damaged or loose.</p>	<p>Any emergency exit door, window, or hatch latch does not operate smoothly and easily when closing or opening the door, window, or hatch.</p> <p>Door hold open feature (if equipped) does not function or secure door in the open position.</p> <p>Inside door handle is not equipped with a guard (rear door only).</p> <p>Any emergency exit does not open and close from the inside and outside easily.</p> <p>Any emergency door or exit is equipped with any type of a hasp, lock, or any other locking device, except for an O.E.M. interlock system.</p> <p>Weatherstrip does not seal. Door does not open at least 90° (degrees).</p>



**B. Body Interior**

Inspection Procedures:		Repair if:	Recommended Out of Service if:
<p><b>4. Emergency Doors &amp; Exits.</b></p>		<p>Cover or padding on bar over door torn or damaged and wooden base is exposed.</p> <p>Roof hatch seal is damaged or dislodged.</p>	<p>Padded bar over door missing or damaged to expose wood base.</p> <p>Emergency door not properly labeled.</p> <p>Emergency window latch does not latch window securely or window does not open easily.</p> <p>Roof hatch does not open easily to full "emergency open" position.</p> <p>Roof hatch does not open to ventilation position.</p> <p>Roof hatches do not have instructions for operation on the inside of the hatch. Any emergency exit window does not have instructions for opening on the inside of the window.</p>

**B. Body Interior**

Inspection Procedures:			Repair if:	Recommended Out of Service if:
<p><b>b. Buzzers</b></p> <p>Check operation of buzzers for emergency door(s), roof hatch(es) and emergency exit windows.</p>			<p>Buzzer gives false alarms.</p>	<p>Buzzer system for emergency door(s), roof hatch(es) or any exit window does not function or is not audible at driver's location.</p>
<p><b>5. Emergency Equipment.</b></p> <p><b>a. Fire Extinguisher.</b></p> <p>Check for presence of fire extinguisher and for the following:</p> <p>1) Pressure: check gauge.</p> <p>2) Tag (Inspection Date): check for presence of inspection sticker or tag and inspection date.</p>				<p>No fire extinguisher on the bus.</p> <p>Labeling is not legible to determine size and types.</p> <p>Pressure above or below green zone.</p>

**B. Body Interior**

Inspection Procedures:		Repair if:	Recommended Out of Service if:
<p><b>5. Emergency Equipment.</b></p> <p>3) Mounting: check for accessibility and secure mounting.</p> <p>4) Rating: check for proper UL.</p> <p>5) Nozzle: check for loose or damaged parts.</p> <p>6) Safety Pin: check for presence of safety pin and tamper proof seal.</p>		<p>Bracket mount to panel is loose.</p>	<p>Fire extinguisher is not accessible to the driver or not secured in the mounting bracket.</p> <p>Rating is less than: 1990 and prior -2.5-lb. 10BC.</p> <p>1992 and later - 5.0-lb. 2A, 10BC or greater.</p> <p>Nozzle or hose missing, obstructed, or excessive damage to any parts of the extinguisher.</p> <p>Safety pin missing or seal broken.</p> <p>Tamper proof seal not of approved type.</p>

**B. Body Interior**

Inspection Procedures:		Repair if:	Recommended Out of Service if:
<p><b>b. First Aid Kit &amp; Body Fluid Kits.</b></p> <p>1) Check the kits mounting and contents.</p> <p>2) Mounting: Check accessibility and mounting of kits. Should be placed in the driver's area in such a manner that they can be easily detached and made portable.</p>		<p>Either kit not labeled.</p> <p>Tamper proof seal broken or missing. Must check contents if seals broken or missing.</p> <p>Loose mounting or bracket.</p> <p>Required contents are missing or incomplete.</p>	<p>Either kit not present.</p> <p>Either kit is not moisture and dust proof, will not seal, will not stay latched, or contents inaccessible due to the condition of the container.</p> <p>Either kit not mounted or inaccessible.</p> <p>Either kit's content not individually sealed.</p>

**B. Body Interior**

Inspection Procedures:			Repair if:	Recommended Out of Service if:
<p><b>5. Emergency Equipment.</b></p> <p><b>c. Reflectors.</b></p> <p>1) Check reflective triangles and mounting.</p> <p>2) Check quantity: 3- each required.</p> <p>3) Check accessibility, mounting and condition of box.</p>			<p>Storage box is broken or will not remain latched</p>	<p>Bus manufactured after 1992 is not equipped with a self-standing, triangular, 17" tall reflectors. Any of the reflectors are broken, deformed or unusable.</p> <p>Box is not accessible or not securely mounted.</p>
<p><b>d. Web Belt Cutter.</b></p> <p>1) Check for the presence of a durable webbing cutter mounted in the driver's compartment and within easy reach of a seated driver.</p>			<p>Webbing cutter is not securely mounted in the driver's compartment and within easy reach of a seated driver.</p>	<p>Buses manufactured before September 2007 with wheelchair positions and restraining devices and no durable webbing cutter is present.</p> <p>Buses manufactured after 2007 and no durable webbing cutter present.</p>

**B. Body Interior**

Inspection Procedures:		Repair if:	Recommended Out of Service if:
<p><b>6. Driver's Seat.</b></p> <p>Check driver's seat and belt for specifications (type and adjustability), condition, mounting, and operation.</p>		<p>Seat adjustment binds or is difficult to operate.</p> <p>Seat adjustment is loose or adjustment hardware is missing.</p> <p>Seat upholstery or foam is deteriorated or damaged.</p>	<p>Driver's seat non-air type will not adjust 4-inches fore and aft, 4-inches up and down, or back will not tilt (except Type A shall be manufacturer's standard).</p> <p>Seat mounting is unstable, loose at floor, or seat mounting hardware is missing.</p> <p>Driver's seat belt is missing.</p>
		<p>Seat bottom is loose in frame or out of position.</p> <p>Seat frame is exposed due to deterioration of upholstery or foam.</p> <p>Seat belt retractor covers or belt covers are damaged or loose.</p>	<p>Mounting of retractors or belt guides is not secure.</p> <p>Seat belt webbing or stitching is frayed or damaged.</p> <p>Seat belt is routed improperly.</p> <p>Seat belt does not extend or retract freely.</p>

**B. Body Interior**

Inspection Procedures:			Repair if:	Recommended Out of Service if:
<p><b>7. Steps</b></p> <p><b>a. Stepwell</b></p> <p>Check specification and condition of stepwell and tread.</p>			<p>Step tread is not secure or sealed at inside edge where it meets next step.</p>	<p>Stepwell tread and leading edge at aisle is not flush and securely adhered, causing a tripping hazard.</p> <p>Stepwell tread ribbing at edge is worn smooth more than 4-inches in width.</p> <p>Stepwell support structure is broken, or stepwell is rusted through.</p> <p>The stepwell area has been damaged or weakened to the extent that a hazard exists.</p>

**B. Body Interior**

Inspection Procedures:		Repair if:	Recommended Out of Service if:
<p><b>8. Passenger Seats</b></p> <p><b>a. Frames</b></p> <p>Inspect passenger seat frames for condition of welds, tubing, and hardware.</p> <p>Check for presence of non-O.E.M. seat frames.</p> <p>Check for presence and condition of passenger seat belts on special needs buses and on Type A buses.</p>			<p>Seat frames or welds are broken or cracked.</p> <p>Any seat back frame is repaired using non-O.E.M. hardware.</p> <p>Any seat hardware has been added or modified to result in projections or sharp edges.</p> <p>There are any non-O.E.M. seat frames installed.</p> <p>Type A (less than 10000 lbs) buses must have a functional seat belt at each passenger position.</p>



**B. Body Interior**

Inspection Procedures:			Repair if:	Recommended Out of Service if:
<p><b>8. Passenger Seats</b></p> <p><b>b. Mounting</b></p> <p>Inspect condition of passenger seat mounting.</p>				<p>Seat mounting at floor or seat rail is loose.</p> <p>Seat mounting fasteners are of lower grade or different type than O.E.M. fasteners for the specific locations.</p>
<p><b>c. Pads</b></p> <p>Inspect seat back foam for specifications and condition.</p>				<p>Seat back padding is of wrong type for specific year model bus.</p> <p>Original thickness or density of any seat back foam around frame has been significantly reduced due to wear, deterioration, or other factors.</p> <p>Foam envelope is split, delaminated, or there is no padding between any portion of seat back frame and covering.</p>

**B. Body Interior**

Inspection Procedures:			Repair if:	Recommended Out of Service if:
<p><b>8. Passenger Seats.</b></p> <p><b>d. Cuts/Upholstery</b></p> <p>Inspect seat upholstery for condition and specifications.</p>			<p>Seat upholstery is cut, torn, or ripped less than 6-inches.</p>	<p>Foam envelope is split, delaminated, or there is no padding between any portion of seat back frame and covering.</p> <p>Seat upholstery is cut, torn, or ripped more than 6-inches.</p> <p>Any portion of seat back or bottom upholstery is missing or repaired improperly, exposing foam.</p>
<p><b>e. Bottoms</b></p> <p>Inspect seat bottoms for securement.</p>				<p>Any seat bottom is not securely anchored to seat frame.</p> <p>Any seat bottom has a protruding edge, or plywood is broken.</p> <p>Any seat bottom padding or cushion has significant deterioration or damage.</p>

**B. Body Interior**

Inspection Procedures:		Repair if:	Recommended Out of Service if:
<p><b>8. Passenger Seats.</b> Inspect flip-up type seat bottom at side emergency door (if equipped) for proper operation. Must have clear access to emergency door with a minimum aisle width of 12" (inches) between seats.</p>			<p>Any flip-up type seat bottom will not: raise or lower; stay in the raised position; automatically retract properly when not occupied.</p> <p>Does not have a clear minimum 12" (inch) aisle width to the side emergency door.</p>
<p><b>f. Modesty Panels and Stanchions.</b> Inspect modesty panels stanchions, and courtesy panels for condition, specifications, mounting, and padding (as required).</p>		<p>Stanchion or modesty panel mounting is loose.</p>	<p>No padded safety barrier in front of any passenger seat that does not have another seat in front of it exception: pre-1990 Type A Bus).</p> <p>Crash barrier foam envelope is split or delaminated, or there is no padding between any portion of barrier frame and covering. Original thickness or density of crash barrier foam around frame has been significantly reduced due to wear, deterioration, or other factors.</p>

**B. Body Interior**

Inspection Procedures:			Repair if:	Recommended Out of Service if:
				Any portion of crash barrier upholstery is missing or not repaired properly, exposing foam. Crash barrier upholstery is cut, torn, or ripped.
<p><b>g. Optional Infant Seating (if equipped).</b></p> <p>Check condition and operation of system.</p>				Seat does not operate or function properly according to manufacturer's operational procedures.
<p><b>h. Passenger Securement Devices (if equipped).</b></p> <p>All buses equipped with 2- or 3-point passenger securement systems shall be equipped with FMVSS 210 compliant seat frames and FMVSS 209 compliant belt assemblies in all passenger seating positions where passenger securement systems are installed.</p>			Belts knotted, misrouted, retractor covers damaged or loose.	Will not latch or stay latched, wrong type, missing, broken, mismatched, improperly installed, or excessively frayed.

**B. Body Interior**

Inspection Procedures:			Repair if:	Recommended Out of Service if:
<p><b>8. Passenger Seats.</b></p> <p>Check condition and operation of passenger securement devices.</p>				
<p><b>9. Sunshield (visor)</b></p> <p>Check driver's sun visor for condition and operation.</p>			<p>Driver's sun visor is cloudy, dirty, or has unauthorized stickers.</p>	<p>Driver's sun visor is too tight or cannot be adjusted.</p> <p>Driver's sun visor is cracked or damaged.</p> <p>Sun visor is missing.</p>
<p><b>10. All Glass.</b></p> <p><b>a. Glass Cracks</b></p> <p>Inspect windshield and all windows for cracks and other damage.</p>				<p>There are any cracks in the windshield in the driver's direct field of vision or any marks which obstruct the driver's vision.</p> <p>Any glass at any location where glass is used and is cracked or broken so that it is likely to cut or injure a person in the vehicle. There is any glass missing.</p>

**B. Body Interior**

Inspection Procedures:		Repair if:	Recommended Out of Service if:
<p><b>10. All Glass.</b></p>			<p>Windshield glass, on the driver's side, has any scratch more than ¼-inch in width and 6-inches within the area covered by the windshield wiper blade, excluding the three inches above the bottom of the windshield. A windshield wiper that remains parked within the driver's side windshield wiper area.</p> <p>There is a pit, chip, or star crack larger than 1-1/2 inches in diameter at any location in the windshield above the three-inch line at the bottom.</p> <p>At any location in the windshield above the three-inch line at the bottom (as measured from the junction of the dash board and the windshield) there is more than one crack from the same point if at least one of the cracks is more than 1-1/2 inches in length. There is any crack that weakens the windshield so that one piece may be moved in relation to the other.</p>

**B. Body Interior**

Inspection Procedures:			Repair if:	Recommended Out of Service if:
<b>10. All Glass.</b>				<p>There is any window to the side of the driver or behind the driver's location which is not laminated or tempered safety glass or Lexan or equivalent.</p> <p>There is any crack in non-laminated safety glass.</p>
<p><b>b. Visibility/Fogging</b></p> <p>1) Check windshield and windows for fogging, reduced visibility, or improper level of tinting.</p>			<p>Glass starting to fog around the edges.</p>	<p>Any mirror, windshield or window fogging or clouding resulting in reduced visibility.</p>
<p>2) Check windshield and windows for objects or signs obstructing driver's vision.</p>				<p>Any object obstructing or interfering with drivers' vision front, sides or rear.</p> <p>Any sticker or other obstruction in the windshield or front side windows other than that required by law or medical waiver.</p>

**B. Body Interior**

Inspection Procedures:			Repair if:	Recommended Out of Service if:
<p><b>10. All Glass.</b></p> <p><b>c. Windows</b></p> <p>Check latches and windows for condition and operation.</p>			<p>Latches are hard to operate, or any window does not move up and down freely.</p> <p>Windows do not stay closed.</p>	<p>Latches are broken.</p> <p>Window will not move (full travel) up and down.</p> <p>There is loose, damaged, or protruding window hardware into the passenger compartment.</p>
<p><b>11. Wheelchair lift, Door &amp; Securement System.</b></p> <p>1) Operate lift through complete cycle and inspect for proper operation, condition, safety features, manual backup system, fluid leaks, mounting, barrier operation, warning light, buzzer operation, and overall mechanical condition.</p>			<p>Dome light at inside lift area is inoperative.</p> <p>Lift door or latch does not operate smoothly.</p> <p>White light at exterior lift area (if originally equipped) is inoperative.</p> <p>Lift control cable or wiring is damaged or routed improperly.</p>	<p>Lift door warning buzzer or light does not operate.</p> <p>Lift door latches, weather stripping, or securement system is damaged or loose.</p> <p>Door switch (to prevent lift operation when the lift door is closed), or other safety override features do not function.</p>



**B. Body Interior**

Inspection Procedures:		Repair if:	Recommended Out of Service if:
		<p>There is fluid seepage at the lift.</p>	<p>Lift will not stay in the fully retracted position (falls against door).</p> <p>Lift platform end barrier or handrail does not raise and lower reliably to the proper position. Barrier does not lock in position, or is damaged.</p> <p>Lift does not fold, unfold, raise, and lower properly, or jerks and binds.</p> <p>There is excessive side play in the lift mechanism when the platform is partially or fully extended.</p> <p>There is excessive side play in the lift mechanism when the platform is partially or fully extended.</p> <p>Lift leaks fluid onto or below floor.</p> <p>Lift is not mounted securely to the vehicle.</p> <p>The lift jacks the vehicle.</p>

**B. Body Interior**

Inspection Procedures:			Repair if:	Recommended Out of Service if:
<p><b>11. Wheelchair Lift, Door &amp; Securement System.</b></p>				<p>Any part of the lift mechanism or hardware is damaged, missing, or not secure, including cams, clips, pins, rollers, and platform fasteners.</p> <p>Manual backup system does not function properly.</p>
<p>2) Inspect wheelchair and occupant securement (tie-down) system for condition, mounting, proper type, and location.</p>			<p>Track is filled with dirt.</p>	<p>Wheelchair tie-down track or fasteners are loose or broken.</p> <p>Wheelchair or occupant securement straps are broken, frayed, or will not operate.</p> <p>Securement systems for buses built after 1989 is not forward facing wheelchair and occupant securement system meeting Virginia specifications.</p> <p>Wheelchair or occupant securement track is mounted using lag bolts or sheet metal screws.</p>

**B. Body Interior**

Inspection Procedures:		Repair if:	Recommended Out of Service if:
<p><b>12. Radio &amp; Cameras (if equipped) .</b></p> <p>Inspect cameras, radio and antenna for condition, mounting and location, routing of wiring, and perform function check.</p>		<p>Radio will not transmit or receive.</p> <p>Mountings are loose.</p>	<p>Driver has to move out of the normal driving position to operate communication controls.</p> <p>Wiring or connectors are un-insulated, installed improperly, misrouted, or unsecured so that it could cause a short.</p>

**B. Body Interior**

Inspection Procedures:		Repair if:	Recommended Out of Service if:
<p><b>13. Interior wiring.</b></p> <p>Inspect visible wiring for mounting, condition, chafing or abrasion, corrosion, loose connectors, or improper repairs.</p>		<p>Wiring or connectors are unsecured, corroded, or improperly routed.</p>	<p>Any wire or connector is cut or severely chafed, or conductor is exposed or routed against a sharp edge, or there is interference with driver's controls. Any connection of any connector is not secure.</p>
<p><b>14. All Openings.</b></p> <p>Check that gear shifter (floor) boot is intact and not damaged.</p> <p>Firewall Seals: Inspect firewall for any cracks, unsealed openings, and sound insulation material.</p> <p>Inspect firewall for any cracks, unsealed openings, and sound insulation material.</p>		<p>Loose boot.</p> <p>Sound deadening /insulation package is unsecured or deteriorated.</p>	<p>Boot is torn, damaged, missing, or not attached to floor.</p> <p>There is any open hole or unsealed area in the firewall.</p>

**B. Body Interior**

Inspection Procedures:			Repair if:	Recommended Out of Service if:
<p><b>15. Storage Compartments.</b></p> <p>Check latch assembly for proper operation.</p>			<p>Latch does not operate properly.</p> <p>Remove any trash, cans, and bottles.</p>	
<p><b>16. Posters &amp; Stickers.</b></p> <p>Inspect for posters or stickers that are not approved.</p>			<p>There is graffiti or unauthorized stickers on interior panels.</p>	
<p><b>17. Loose Objects &amp; Cleanliness.</b></p> <p>a) Loose Objects:</p> <p>Check to see that all objects within the bus are secured.</p>				<p>Loose objects such as trashcans, oil cans, or other loose items are present which are not secured in a glove box or other secured container.</p>

**B. Body Interior**

Inspection Procedures:			Repair if:	Recommended Out of Service if:
<p><b>17. Loose Objects &amp; Cleanliness.</b></p>				<p>Any aerosol can(s) or other container(s) of liquid(s) of flammable or volatile chemical are on the bus.</p> <p>Any aerosol or non-aerosol chemical container present that is not labeled.</p> <p>Any carpeting or non-O.E.M floor mats.</p>
<p>b) Cleanliness</p> <p>Inspect interior for cleanliness.</p>			<p>Bus is dirty.</p>	<p>Bus dirty and unsafe/unsanitary to operate and presents a potential health hazard.</p>
<p><b>18. Handrails</b></p> <p>Check for presence and secure mounting of entrance handrail(s).</p>				<p>Entrance handrail(s) is missing or not securely mounted.</p> <p>Handrail and/or any hardware missing damaged or have unauthorized modifications</p>

**B. Body Interior**

Inspection Procedures:		Repair if:	Recommended Out of Service if:
<p><b>18. Handrails</b></p> <p>Check handrail(s) for required modification(s) (if equipped). If no required modification is present, perform a NHTSA string and nut test.</p>			<p>Handrail(s) fails NHTSA string and nut test.</p>

**C. Exterior**

Inspection Procedures:		Repair if:	Recommended Out of Service if:
<p><b>1. Body Damage.</b></p> <p>Check body exterior for accident damage, scratches, dents, etc.</p>		<p>Body has small dents, scratches, etc.</p> <p>Body has small rust spots or water leaks.</p>	<p>Any body part is damaged or dislocated creating a protrusion or sharp edge.</p> <p>Body panels, rivets, or other components are damaged or corroded to the point where joint strength or body structural integrity is compromised.</p>
<p><b>2. Stirrup Steps.</b></p> <p>Check for condition and mounting of stirrup steps and grab handles.</p>		<p>Any stirrup step loose or missing.</p>	<p>Any stirrup step or grab handle is broken.</p>
<p><b>3. License Plates.</b></p> <p>Inspect for damage, secure mounting and visibility.</p>		<p>Plates damaged, loose or visibility blocked by crossing control arm.</p>	<p>Plates missing.</p>



**C. Exterior**

Inspection Procedures:			Repair if:	Recommended Out of Service if:
<p><b>4. Tow Hooks.</b></p> <p>Inspect for damage and secure mounting.</p>			<p>Damaged or missing tow hooks (if equipped)</p>	
<p><b>5. Bumpers</b></p> <p>Check bumpers for mounting, condition, color, and body seal (rear bumper).</p>			<p>Bumper is not black.</p> <p>Bumper is equipped with any unauthorized stickers or decals.</p>	<p>Bumper is significantly bent or has protruding metal.</p> <p>Bumper mounting system has cracked, broken, or bent brackets, braces, welds, or missing or loose fasteners.</p> <p>Bumper is cracked, torn or broken.</p> <p>Bumper is not O.E.M or approved type.</p>

**C. Exterior**

Inspection Procedures:		Repair if:	Recommended Out of Service if:
<p><b>6. Tires and Wheels.</b></p> <p>a) <b>Tread Depth</b></p> <p>Inspect and measure all tires for tread depth.</p>			<p>Measured tread depth of either front tire is less than 4/32-inch or less when measured at any tread point at any point on a major tread groove. Measurement shall not be taken at a wear bar.</p> <p>Measurement shall be taken at the most worn major tread groove of the tire.</p> <p>Measured tread depth of either rear tire is less than 2/32 inch when measured in two adjacent tread grooves where tread is thinnest.</p> <p>Any front tire is recapped or re-grooved type tire.</p> <p>A tire is regrooved and not marked "regroovable".</p> <p>There is evidence that any tire has been re-grooved using a procedure not approved by tire manufacturer or dealer.</p>

**C. Exterior**

Inspection Procedures:		Repair if:	Recommended Out of Service if:
<p><b>6. Tires and Wheels.</b></p> <p>b) <b>Pressure</b></p> <p>With tire cold, check pressures of all tires.</p>		<p>Pressure not within range marked on the sidewall.</p> <p>Pressure in the dual tires not within 10 percent of each other.</p>	<p>Any tire flat or has audible air leak.</p>
<p>c) <b>Damage</b></p> <p>Inspect for damage to wheels and tires.</p>		<p>There is foreign material in the tire tread, which could cause damage or loss of air pressure.</p>	<p>There are any cuts, abrasion, or other damage to tire sidewall resulting in exposed or damaged cord.</p> <p>There is any evidence of separation, bulges (other than normal manufacturer bulge), or other damage within the carcass of the tire. There are any cracks that run around the bead or sidewall of the tire.</p> <p>On retread tire there is any separation of the tire tread from the tire carcass, which could result in tire or tread failure.</p>

**C. Exterior**

Inspection Procedures:			Repair if:	Recommended Out of Service if:
<p><b>6. Tires &amp; Wheels.</b></p>			<p>Any valve cap is missing.</p> <p>There are minor dents or bends in a rim.</p>	<p>Any valve stem is damaged or not-aligned so that tire cannot be filled with air.</p> <p>There are any cracks or breaks at the lug holes or any other part of a rim or cast spokes.</p>
<p>d) <b>Matching</b></p> <p>Inspect for matching of tire construction, design, size, and load rating on each axle.</p>				<p>There is mismatching of inner and outer dual tire diameter greater than 3/8-inch.</p> <p>There is any tire marked for other than highway use. Any tire is not of proper type, size, and minimum load rating.</p> <p>Radial and bias ply tires are intermixed on the same axle.</p>

**C. Exterior**

Inspection Procedures:			Repair if:	Recommended Out of Service if:
<p><b>6. Tires &amp; Wheels.</b></p> <p>e) <b>Alignment</b></p> <p>Inspect tires for evidence of proper alignment.</p>			<p>Any tire is feather-edged, cupped, or has uneven tread wear.</p> <p>Lateral run out of any tire/rim assembly exceeds ¼-inch.</p>	<p>Tires/wheels are grossly misaligned, affecting steering control.</p>
<p>f) <b>Wheel Hardware.</b></p> <p>Inspect for presence, type, condition, and securement of all wheel hardware.</p> <p>Check for proper spacing of rear dual wheels and tires (proper spacer width).</p>				<p>Stud holes are elongated.</p> <p>Any wheel nut, stud, bolts, clamp or other fasteners are loose, broken, cracked, stripped, missing, damaged or otherwise ineffective.</p> <p>Any welded repair on wheels mounted on the steering axle.</p>

**C. Exterior**

Inspection Procedures:		Repair if:	Recommended Out of Service if:
<p><b>7. Lights and Signals</b></p> <p>Check both headlights for brightness, operation, condition of sealed beams, and visible misaiming. Check high beam indicator operation and headlight switch.</p>		<p>Left and right sealed beams are of different type (halogen vs. conventional).</p>	<p>Either sealed beam does not light on low and high.</p> <p>Any sealed beam lens is fogged, cracked, or light is dim.</p> <p>Dimmer switch sticks, is hard to operate, or doesn't function.</p> <p>Headlight switch is damaged, not securely mounted, or knob is missing.</p> <p>Lights go out after being on a short time, or operation is intermittent.</p> <p>Upon visible inspection, there is any obvious misaiming of headlights.</p>

**C. Exterior**

Inspection Procedures:		Repair if:	Recommended Out of Service if:
<p><b>7. Lights &amp; Signals</b></p> <p>a) <b>Turn Signals</b></p> <p>Check turn signals (including bulbs and lenses) for operation, condition, and specifications.</p>		<p>Any front, rear, or side-mounted turn signal lens is cracked.</p> <p>Turn signal does not properly indicate right or left signal.</p> <p>Turn signal does not cancel or return to neutral position.</p>	<p>Lens has a piece broken from it. The lens may have one or more cracks provided an off - color light does not project through the cracks(s). Taping or gluing cracks or pieces is not allowed.</p> <p>Any front or side mounted turn signal does not flash or dim.</p> <p>Turn signal does not flash between 60- to 120-times per minute.</p> <p>Turn signal does not initiate turn signals or will not maintain set position.</p> <p>Any turn signal lens has darkened, faded, or is dirty, significantly affecting visibility or color of the light.</p>
<p>b) <b>Turn Signal</b></p> <p>Check 4-way hazard lights for operation and condition.</p>		<p>Any lens is cracked or dirty.</p> <p>Either indicator fails to function properly.</p>	<p>Any 4-way hazard light fails to function.</p> <p>Hazard lights do not flash between 60- to 120-times per minute.</p>

**C. Exterior**

Inspection Procedures:		Repair if:	Recommended Out of Service if:
<p><b>7. Lights &amp; Signals</b></p>		<p>Either indicator fails to function properly.</p>	<p>Hazard warning lamps do not flash simultaneously.</p> <p>Switch does not function or will not maintain set position with steering wheel in the straight-ahead position.</p> <p>Off-colored light projects through crack in lens.</p>
<p>c) <b>Side Marker.</b></p> <p>Check side marker lights for operation and condition.</p>		<p>Any side marker light fails to function, is cracked or damaged.</p>	
<p>e) <b>Brake Lights</b></p> <p>Check brake lights and lens(es) for operation, condition, and specifications.</p>		<p>One brake light on either or both sides fails to function (4 brake light system only).</p>	<p>Half or more of the O.E.M installed brake lights fail to function when the brake pedal is depressed (i.e. 1- of 2-brake light system; 2- of 4-brake light system, or more).</p> <p>For buses with only one brake light per side, either brake light fails to function.</p>



**B. Exterior**

Inspection Procedures:		Repair if:	Recommended Out of Service if:
<p><b>7. Lights &amp; Signals.</b></p>		<p>Any brake light lens cracked.</p>	<p>After brake pedal is released, brake light switch sticks, or lights stay on.</p> <p>Any brake light lens is damaged and white light is visible.</p> <p>Any brake light lens is not red or is not proper type meeting SAE specification.</p> <p>Any brake light lens has darkened, faded, or is dirty, significantly affecting the visibility or color of the light.</p>
<p>f) <b>Tail Lights.</b></p> <p>Check tail light(s) and lens(es) for operation, condition, and specifications.</p>		<p>One (1) tail light on either or both sides fails to function (4-tail light system only).</p> <p>Any lens cracked and white light not visible.</p>	<p>Half or more of the O.E.M. installed tail lights fail to function when the headlight switch is in either the park or headlight position. (i.e. 2 of 4, 1 of 2 or more)</p> <p>Any tail light lens is damaged and white light is visible.</p> <p>Any tail light lens is not red or is not proper type meeting SAE specifications.</p>

**C. Exterior**

Inspection Procedures:			Repair if:	Recommended Out of Service if:
<b>7. Lights &amp; Signals</b>				Any tail light lens has darkened, faded, or is dirty, significantly affecting the visibility or color of the light.
g) <b>Back up lights.</b>  Check backup lights for proper operation and condition.			One (1) of 2-backup lights (if equipped) doesn't function.  Any backup lens is cracked.	All of the installed backup lights fail to function.  Backup lights stay on all the time or stay on in any gear other than reverse.
h) <b>Backup Alarm.</b>  Check for presence of back up alarm (buses manufactured starting November 1995) and dash sticker. Check operation of alarm by placing transmission in reverse (engine running) and listening for alarm sound.			Alarm mounting loose.	Backup alarm does not sound.

**C. Exterior**

Inspection Procedures:		Repair if:	Recommended Out of Service if:
<p><b>7. Lights &amp; Signals</b></p> <p><b>i) Park Lights</b></p> <p>Check park lights for proper operation and condition.</p>		<p>One (1) front park light does not function on either side (four either side (four (4) park light system).</p> <p>Any park light lens is cracked or damaged.</p>	<p>Half or more of the O.E.M installed front parking lights, on either side, fail to function when the switch is in park or headlight position (i.e. 1- of 2-parking light system; 2- of 4-parking light system, or more).</p>
<p><b>j) Clearance, Marker &amp; ID Lights.</b></p> <p>Check light(s) and lens(es) for operation, condition, and location.</p>		<p>Any clearance or ID light fails to function.</p> <p>Any clearance or ID lens is not amber if in front of the rear wheels or red if at or behind the rear wheels.</p> <p>Any clearance light switch is hard to operate, sticks, or knob is missing.</p>	<p>All clearance lights on either side of the bus are inoperative.</p> <p>All clearance and ID lights on either the front or the rear of the bus are inoperative.</p> <p>Either rear corner-mounted clearance light is inoperative.</p> <p>Any clearance light lens has darkened, faded, or is dirty, significantly affecting the visibility or color of the light.</p>

**C. Exterior**

Inspection Procedures:			Repair if:	Recommended Out of Service if:
<b>7. Lights &amp; Signals</b>			Any clearance or ID light lens is damaged and no white light is visible.	Any clearance or ID light lens is damaged and white light is visible.
k) <b>License plate/light(s) :</b> Check license plate lights(s) and lens(es) for condition and operation.			License plate light(s) is inoperative.	
l) <b>Strobe light:</b>  Check roof mounted white flashing strobe light for operation, location, and condition.			Strobe light fails to function. Switch is hard to operate or sticks. Strobe light lens is cracked or damaged.	Strobe light is missing or does not function.
<b>8. Reflectors:</b>  Check reflectors for condition and location.			Any reflector is damaged, cracked or faded.	Any required reflectors are missing. Any pieces from crack missing.

**C. Exterior**

Inspection Procedures:			Repair if:	Recommended Out of Service if:
<p><b>9. Reflective Markings.</b></p> <p>Check reflective markings for coloration, reflect ability and condition.</p> <p>Check for presence of reflective markings around any emergency exit, door, window, or around roof hatch as required by F.M.V.S.S. 217.</p>			<p>Reflective markings, other than those around any emergency exit door or roof hatch, required by F.M.V.S.S. 217, are faded, discolored, damaged or peeling.</p>	<p>Any required reflective markings are missing.</p> <p>Any emergency exit, door, or roof hatch perimeter reflective markings significantly faded or discolored.</p>
<p><b>10. Lettering/Paint</b></p> <p>Check paint on body and trim for required coloration and condition.</p>			<p>Paint is faded, discolored, rusted, or damaged.</p> <p>Trim, rub rails, warning light hoods or background are not black.</p>	<p>Paint is not National School Bus Yellow.</p> <p>Any area of paint is missing in excess of 200-inches.</p>

**C. Exterior**

Inspection Procedures:		Repair if:	Recommended Out of Service if:
<p><b>10. Lettering/Paint</b></p> <p>Check all lettering for required type, size, location, and color.</p>		<p>Fuel type lettering is not present.</p> <p>Four inch (4") high bus number missing from sides or back of the bus or missing from front bumper.</p>	<p>Any required lettering is not readable.</p> <p>Bus is not equipped with the following lettering:</p> <ol style="list-style-type: none"> <li>1) Eight inch (8") front and rear.</li> <li>2) Four inch (4") "Name of" county or city public schools on the left and right sides of the body.</li> <li>3) Handicap symbol for wheelchair equipped buses starting 1992.</li> <li>4) Minimum two inch (2") lettering "Emergency Door" at top or above the door.</li> <li>5) Emergency door(s) (all years) and window(s) or hatch(es) (1990 and later) not labeled "Emergency Exit" or "Emergency Door" on inside or outside.</li> </ol> <p>Any bus with wheel chair lift and handicap symbol is not reflective white on blue background, maximum of 12 square inches.</p>

**C. Exterior**

Inspection Procedures:		Repair if:	Recommended Out of Service if:
<p><b>11. Mirrors</b></p>		<p>Mirror brackets are bent or broken, or mounting is insecure and mirror will remain properly adjusted.</p>	<p>Mirror brackets are bent or broken, or mounting is insecure and mirror will <b>not</b> stay in the adjusted position or cannot be adjusted.</p> <p>Cross view mirrors will not stay beyond the leading edge of the vehicle.</p> <p>Any mirror reflective surface deteriorated.</p> <p>Reflecting surface of the mirror is cracked, broken, peeled, pitted, clouded, tarnished, has sharp edges, reflects more than one image, or is not mounted securely.</p>
<p><b>12. Storage &amp; Chain Boxes.</b></p> <p>Check latches, hinges, and seals.</p>		<p>Latches or hinges broken. Seals deteriorated.</p> <p>Unwanted or unauthorized items.</p>	

**D.Engine  
Compartment**

Inspection Procedures:			Repair if:	Recommended Out of Service if:
<p><b>1. All Belts</b></p> <p><b>A) Tension</b></p> <p>Visually and physically check all drive belts for proper tension. (fig 1, pg 133)</p> <p><b>Note:</b> If available, use a tension gauge. If a gauge is not available, use a ruler to measure the deflection of the belt(s) up and down at the widest point between the drive and driven pulley(s).</p>			<p>Any belt exceeds tension reading recommended by manufacturer, if a tension gauge is used. (fig 1, page 133)</p> <p>Using ruler method, any belt is less than ½-inch deflection (too tight) when firm pressure is applied. (fig 2, page 133)</p>	<p>Any belt tensioner does not pivot or move and apply spring pressure on belt.</p> <p>Tension on any belt is too loose (based on specifications of type tension gauge used).</p> <p>Tension of any belt (using ruler method) is too loose when firm pressure is applied.</p>
<p><b>B) Belt Alignment</b></p> <p>Visually inspect belts for proper alignment.</p>			<p>Any belt not inline (less than 1/16 inch per foot).</p>	<p>Belt misalignment is excessive and could result in failure (More than 1/16 inch per foot).</p>



**D. Engine  
Compartment**

Inspection Procedures:			Repair if:	Recommended Out of Service if:
<p><b>1. All Belts</b></p> <p>C) <b>Condition</b></p> <p>Visually inspect belt(s) for glazing, oil contamination, dry rotting, cuts, and separation of plies. Check belts for twisting or distortion.</p>			<p>Any belts are glazed.</p>	<p>Any belt is oil saturated, dry-rotted, or cut or plies of belt(s) are separated.</p>
<p>D) <b>Routing</b></p> <p>Visually inspect belt(s) for rubbing or contact with objects other than pulleys and for routing around correct pulleys.</p>				<p>Any belt is making contact with objects other than pulley(s).</p> <p>Any belt is routed around incorrect pulley(s).</p>
<p><b>2. Leaks</b></p> <p>A) <b>Fuel Tank</b></p> <p>Inspect fuel tank assembly for leaks.</p>				<p>There is any fuel leakage from the tank, connections, or cap, or cap is missing. The fuel tank has any cracks. Any connection(s) are loose at the tank.</p>

**D.Engine  
Compartment**

Inspection Procedures:			Repair if:	Recommended Out of Service if:
<p><b>2. Leaks</b></p> <p><b>B) Coolant</b></p> <p>Inspect all potential locations for coolant leaks.</p>			<p>There is coolant seepage at radiator, hoses, heater core, engine oil cooler, thermostat housing, head gaskets, freeze plugs, reservoir, water pump, or other potential locations.</p>	<p>Leakage is excessive and could result in imminent engine failure.</p>
<p><b>C) Oil</b></p> <p>Inspect for engine oil leaks at all potential locations and determine severity.</p>			<p>Engine oil leakage is causing deterioration of any rubber parts, such as steering linkage boots, hoses, etc.</p> <p>Engine oil is dripping at any location except on exhaust system.</p>	<p>Leakage is excessive and could result in imminent engine failure.</p> <p>Engine oil is dripping on any portion of the exhaust system.</p> <p>There is a drip shield installed to divert oil from the exhaust system.</p>

**D.Engine  
Compartment**

Inspection Procedures:			Repair if:	Recommended Out of Service if:
<p><b>2. Leaks</b></p> <p>D) <b>Power Steering</b></p> <p>Inspect for power steering fluid leak at all potential locations and determine severity.</p>			<p>Power steering fluid is causing deterioration of any rubber parts, such as steering linkage boots, hoses, etc.</p> <p>Power steering fluid is seeping.</p>	<p>Power steering fluid is dripping.</p> <p>Power steering reservoir cap or dipstick is missing.</p>
<p>E) <b>Exhaust System</b></p> <p>With engine running and at operating temperature, inspect exhaust system for leaks, condition, and securement.</p>			<p>There is any physical damage to exhaust system.</p> <p>Any exhaust junction gasket or hardware is broken or missing.</p>	<p>There is any leakage, which is audible or can be felt around any portion of the exhaust system including manifold(s), pipe sections, or any junction.</p> <p>Tail pipe opening smashed or pinched.</p> <p>Exhaust does not discharge at or within 15-inches forward of the rearmost part of the vehicle for diesel and 6-inches forward of the rearmost part of the vehicle for gasoline vehicles.</p>

**D. Engine  
Compartment**

Inspection Procedures:			Repair if:	Recommended Out of Service if:
<b>2. Leaks</b>				<b>Exception:</b> Type A buses may discharge behind the rear wheel.
<b>3. Road Speed Governor (If Equipped) .</b>  Check for proper connections. Check governor performance and shutdown of engine.				Engine will not shutdown.  Governor does not limit engine RPM.
<b>4. Fan Assembly.</b>  Check fan blade and fan clutch assembly for securement and condition.				Fan has any cracked, bent, or broken blades.  Any portion of fan mounting is loose. Fan clutch is seized or loose.  Any leak, mounting, rotation or function problem with hydraulic motor. Electric fan does not operate.  Hydraulic solenoid valve inoperative.  Wiring for fan (electric) or solenoid (hydraulic) is not secured, loose, damaged, or missing.

**D.Engine  
Compartment**

Inspection Procedures:			Repair if:	Recommended Out of Service if:
<p><b>5. Water Pump.</b></p> <p>Check condition of water pump and pulley.</p>			<p>There is evidence of coolant seepage from water pump, seal, gasket surface, or weep hole.</p> <p>Water pump fasteners are loose, damaged, or missing.</p>	<p>Water pump is noisy, bearing is damaged, or coolant is dripping out.</p>
<p><b>6. Air Compressor.</b></p> <p>Check securement and condition of the air compressor, and filter assembly.</p>			<p>Air compressor air filter (if equipped) is dirty.</p>	<p>Any portion of the air compressor, compressor air filter (if equipped), filter and compressor mounting brackets, filter cover, or fastener is cracked, loose or missing.</p> <p>Any loose, leaking or damaged hose or plumbing between engine air filtration system and compressor (vehicles with shared filter).</p> <p>Any oil or coolant leaks from compressor or plumbing.</p>

**D.Engine  
Compartment**

Inspection Procedures:			Repair if:	Recommended Out of Service if:
<p><b>6. Air Compressor</b></p>				<p>Compressor drive belts in condition of impending or probable failure.</p> <p>Any problem with piggy- backed power steering pumps either mounting or leaks.</p>
<p><b>7. All Piping and Hoses.</b></p> <p>Check for proper routing and securement.</p> <p>Check for securement.</p>				<p>Routing securement in condition of impending or probable system failure.</p>
<p><b>8. All Wiring.</b></p> <p>Check routing, securement, and condition of all wiring and any electrical cable in the engine compartment.</p>			<p>There is any loose, damaged, or corroded wiring connector or terminal end.</p>	<p>There is any unsecured or poorly routed wiring that could cause potential short or fire due to abrasion or heat damage.</p> <p>There is any burnt wiring or wiring (other than ground wires) missing insulation.</p>

**D.Engine  
Compartment**

Inspection Procedures:			Repair if:	Recommended Out of Service if:
<p><b>9. Steering Gear and Hydraulic Pump.</b></p> <p>Check fluid level.</p> <p>Check mounting bolts.</p>				<p>Fluids below operating level.</p> <p>Any mounting bolts loose or missing.</p> <p>Frame, frame associated rivets or fasteners are loose, damaged or missing.</p> <p>There is any binding in gear box.</p> <p>Any cracks in gear box or mounting brackets.</p>
<p><b>10. Master Cylinder.</b></p> <p>Check fluid level.</p>				<p>Level of brake fluid in either side of master cylinder reservoir is lower than ¼-inch from top or below "Add" mark.</p>

**D.Engine  
Compartment**

Inspection Procedures:			Repair if:	Recommended Out of Service if:
<p><b>10. Master Cylinder</b></p> <p>Check mounting bolts.</p>				<p>Brake fluid or power-assist fluid shows evidence of excessive water, oil, or dirt contamination. Brake power-assist hydraulic fluid is below cold "Add" mark.</p> <p>Any mounting bolts loose or missing.</p>
<p><b>11. Vacuum, Electric, and Hydraulic Brake Boosters.</b></p> <p>Check all connections and mounting.</p>				<p>Lines and hoses are leaking. The system leaks. Lines and hoses are collapsed, broken, chafed, insecurely mounted, less than 1 ½-inch from any part of the exhaust system. Clamps are loose or broken.</p> <p>Any tank is missing, loose, damaged or leaking.</p> <p>The vacuum booster is loose, damaged or mounting is cracked.</p>



**D.Engine  
Compartment**

Inspection Procedures:		Repair if:	Recommended Out of Service if:
<p><b>12. Radiator Mounting</b></p> <p>Check radiator assembly and mounting for securement and condition.</p>		<p>Any portion of radiator or mounting system is cracked, damaged, or has loose or missing fasteners.</p>	<p>Any portion of the radiator is cracked and leaking.</p>
<p><b>13. Fuel System, Fuel Lines &amp; Carburetor (if equipped)</b></p> <p>Visually check the condition, operation, and securement of all fuel system components, including, pumps, fuel lines and routing in the engine compartment.</p>		<p>There is evidence of contamination in the water separator (if equipped).</p>	<p>There is any unsecured, or poorly routed or loose fuel line or hose that could cause potential fire due to abrasion or heat damage.</p>

**D.Engine  
Compartment**

Inspection Procedures:			Repair if:	Recommended Out of Service if:
<p><b>14. Fuel System, Fuel Lines &amp; Carburetor (if equipped).</b></p>				<p>Any fuel system connection or component that is stripped, loose, cracked, or leaking.</p> <p>Any fuel system component is damaged or not mounted securely.</p> <p>Any evidence of fuel leaking internally and contaminating oil or coolant (pump, tubes, etc).</p> <p>Any electric or mechanical shutdown that does not operate properly.</p> <p>Any accelerator return spring weak, broken, or missing.</p>
<p><b>15. Batteries</b></p> <p><b>a. Batteries:</b></p> <p>1) Check for condition and type.</p>			<p>Batteries are the wrong type for vehicle, or in multi battery sets are not matched.</p> <p>Batteries top or sides are corroded, greasy, dirty, wet with electrolyte.</p>	<p>Battery is cracked or damaged.</p> <p>Battery will not start vehicle.</p>

**D.Engine  
Compartment**

Inspection Procedures:		Repair if:	Recommended Out of Service if:
<b>15. Batteries</b>		Electrolyte is low. (if applicable).	
<b>b. Hold-down</b>  1) Check for tightness, condition, and type of battery hold-down.		Hold-down assembly tray is corroded or damaged but battery is secure.	Hold-down assembly or tray is loose, corroded, or damaged causing insecure mounting of battery.  Hold down is flexible strap or other non-rigid design.  Hold-down /batteries are mounted in such a way that they could short out against the hold-down and /or any body or chassis component.
<b>c. Battery Terminals.</b>  1) Check terminals for type, cleanliness, tightness, and condition.		Terminals are dirty, corroded or loose and/or missing.	Batteries have the wrong style terminals for vehicle, or are installed with adapters.
<b>d. Battery Cables</b>  1) Check cable assemblies for routing, securement, condition, and size.		Cable corroded.  Negative cable or insulation is cracked or damaged.	Positive cable is cracked or damaged.

**D.Engine  
Compartment**

Inspection Procedures:			Repair if:	Recommended Out of Service if:
<p><b>16. Batteries</b></p>			<p>Negative cable is misrouted, unsecured, or grommet is missing to allow it to abrade on any metal or sharp edge.</p> <p>Cable appears to be of excessive length.</p> <p>Flat braided engine cable is frayed, corroded.</p>	<p>Positive cable is misrouted, unsecured, or grommet is missing to allow it to abrade on any metal or sharp edge.</p> <p>Cable is routed against the exhaust or any other extremely hot surface.</p> <p>Cable is smaller than original equipment size.</p> <p>Flat braided engine cable ends are not secured.</p>
<p><b>e. Tray</b> 1) Check battery tray for operation, condition and securement.</p>			<p>Battery slide tray is corroded, dirty or hard to slide in and out.</p>	<p>Battery slide tray securement device or tray stop is missing or nonfunctional.</p> <p>Battery tray does not slide in and out.</p> <p>Battery slide tray or box is damaged or deteriorated reducing security of batteries.</p> <p>Battery box door does not open or will not stay latched.</p>

**D.Engine  
Compartment**

Inspection Procedures:			Repair if:	Recommended Out of Service if:
<p><b>17. Crankcase Vent Valve</b></p> <p>Clean and inspect for proper operation.</p>				<p>Component fail to function as designed.</p>
<p><b>18. Cold Starting Device</b> (if equipped).</p> <p>Check for proper operation.</p>				<p>Component fail to function as designed.</p>

**D. Engine  
Compartment**

Inspection Procedures:			Repair if:	Recommended Out of Service if:
<p><b>19. Turbocharger</b></p> <p>1) Check mounting bolts.</p> <p>2) Check air intake and exhaust hoses and piping for tightness.</p>			<p>Mounting bolts loose.</p> <p>Hoses and piping loose.</p>	
<p><b>20. Vibration Damper.</b></p> <p>Check for play or looseness.</p>			<p>Out of manufacturer's specification.</p>	
<p><b>21. Engine Mounts.</b></p> <p>Inspect front and rear insulators for deterioration and looseness.</p>			<p>Mounting bolts not tightened to factory specification.</p> <p>Insulators deteriorated.</p>	<p>Engine mounts broken or missing.</p>

**D.Engine  
Compartment**

Inspection Procedures:		Repair if:	Recommended Out of Service if:
<p><b>22. Cooling System.</b></p> <p>Check coolant level (antifreeze) level and condition.</p>		<p>Coolant level in radiator or reservoir is low but still visible in the tank.</p> <p>Coolant shows evidence of rust and corrosion contamination.</p>	<p>Coolant level in radiator or reservoir is low and not visible in tank.</p> <p>Coolant shows evidence of excessive oil or fuel contamination.</p>

**E. Front Axle**

Inspection Procedures:		Repair if:	Recommended Out of Service if:
<p><b>1. Fluid Leaks.</b></p> <p>Check for fluid leaks at wheel seals, backing plates and underside of engine.</p>			<p>Either front wheel seal is damaged or leaking.</p>
<p><b>2. Steering Linkage.</b></p> <p><b>A. Drag link (if equipped)</b></p> <p>Check the drag link ends, shaft and fasteners for looseness and condition.</p>		<p>Drag link has more than 1/16-inch and less than 1/8-inch axial play.</p> <p>Any drag link end fitting (as equipped) is loose, or missing, or will not take grease.</p> <p>Drag link end boot is damaged or missing.</p> <p>Drag needs lubrication.</p>	<p>Any motion, other than rotational, between any linkage member and its attachment point of more than 1/8-inch measured with hand pressure only.</p> <p>Loose clamps, clamp bolts on tie rod ends or drag links.</p>



**E. Front Axle**

Inspection Procedures:			Repair if:	Recommended Out of Service if:
<p><b>2. Steering Linkage.</b>  <b>B. Pitman Arm</b>            Check the pitman arm for looseness or misalignment at sector shaft splines &amp; looseness at all joints. Check looseness of pinch bolt &amp; fasteners &amp; condition of pitman arm.</p>			<p>Pitman arm grease fitting (if originally equipped) is loose or missing.</p>	<p>Any looseness of the pitman arm on the steering gear box, output shaft or gear box.             Pinch bolt at sector shaft is loose or missing.</p>
<p><b>C. Steering Arm</b>            1) Check upper steering arm (Ackerman Arm) &amp; left &amp; right side lower steering arms for securement &amp; condition.            2) Check condition &amp; securement of steering stops &amp; lock nuts.</p>				<p>Any steering arm has bent, is cracked, or is damaged.             Any steering arm attachment point is loose, or any fasteners or cotter pin is missing.             Either steering stop or lock is loose, damaged, or missing.</p>
<p><b>D. Tie Rod and Ends</b>            1) Check Tie rod ends, tie rod, dust boots, &amp; clamps or fasteners (as equipped) for looseness, damage, &amp; condition.</p>			<p>Tie rod end needs lubrication.</p>	<p>Tie rod end clamps, fasteners, or cotter pin is stripped, missing or loose.</p>

**F. Front Axle**

Inspection Procedures:			Repair if:	Recommended Out of Service if:
<p><b>2. Steering Linkage.</b></p>			<p>Any tie rod end grease fitting is loose, or missing, or will not take grease.</p> <p>Any tie rod end has more than 1/16-inch and less than 1/8-inch play. (see fig 4, page 134)</p>	<p>Any clamp (as equipped) not positioned.</p> <p>Any tie rod end is cracked or damaged.</p> <p>Any tie rod or end bent, cracked, broken, or threads are damaged in any way.</p> <p>Any tie rod end has more than 1/8 inch axial play. (see fig 4, page 134).</p> <p>Tie rod end has more than end ball stud is loose in steering arm or idler arm. (fig 5, page 135).</p>
<p><b>3. Shock Absorbers.</b></p> <p>Inspect shocks for condition and securement.</p>			<p>There is wetness around shock body due to leaking shock fluid.</p>	<p>Any shock mounting or fastener is loose, missing, cracked, or broken.</p> <p>Any shock is broken.</p> <p>Any shock fails to function.</p>

**E. Front Axle**

Inspection Procedures:			Repair if:	Recommended Out of Service if:
<p><b>4. Brake Lining.</b></p> <p>Inspect linings and foundation brake hardware for contamination, wear, damage, and securement.</p>			<p>Lining wear is extremely uneven left and right.</p>	<p>Brake lining is worn to or beyond allowable limits.</p> <p>Lining is broken, cracked, or loose on shoe.</p> <p>Friction surface is contaminated with oil, grease, or brake fluid.</p> <p>Lining is not the proper size.</p> <p>Shoe platform or web is cracked or damaged.</p> <p>There is any loose, damaged, or missing foundation brake hardware within the drum.</p>
<p><b>5. Slack Adjusters.</b></p> <p>A. Inspect slack adjusters and S-cam assemblies for wear, condition, operation and securement.</p>				<p>Any portion of slack adjuster or S-cam is missing, broken, cracked, or badly worn.</p> <p>Slack adjuster is not mounted properly or anchor bracket is loose or damaged.</p>

**E. Front Axle**

Inspection Procedures:			Repair if:	Recommended Out of Service if:
<p><b>5. Slack Adjusters.</b></p>				<p>S-cam shaft and/or S-cam bushing total wear (up and down) is greater than .30-inch.(fig. 5, page 135)</p> <p>Manual adjusters have a problem with the locking mechanism on the adjusting bolt.</p> <p>S-cam snap ring is broken or missing.</p> <p>Any slack adjuster is not operating properly.</p> <p>Any slack adjuster is not adjusted properly.</p>
<p><b>6. Springs</b></p> <p>Inspect front springs for condition, securement, and alignment.</p>			<p>There are any loose, missing, broken or worn springs clips.</p> <p>Any coil or leaf spring has flattened, and ride height is less than manufacturer's specifications.</p>	<p>Any leaf spring(s) is broken, cracked, or missing.</p> <p>Spring eye is worn or spread such that bushings are loose in spring eye.</p>

**E. Front Axle**

Inspection Procedures:			Repair if:	Recommended Out of Service if:
<p><b>6. Springs</b></p>			<p>Either front spring saddle (if equipped) is worn out or missing.</p> <p>Rubber frame bumper is missing.</p> <p>Ride height not adjusted properly (air suspension).</p>	<p>Any coil spring(s) is broken, insecurely mounted, non-O.E.M. or non-O.E.M. blocks or spacers are installed.</p> <p>There is any misalignment of spring leaves or other evidence that center pin is loose or broken.</p> <p>Either front coil or leaf spring is worn so that rubber frame bumper is damaged or worn due to frequent bottoming of front suspension.</p> <p>Any alignment wedge is loose or damaged.</p> <p>On any air bag type spring assembly, air bag is damaged or leaking or airlines and valves are damaged or leaking.</p>
<p><b>a. U-Bolts</b></p> <p>Inspect spring U-bolts for condition and securement.</p>			<p>Any U-bolt is misaligned.</p>	<p>There is rust underneath U-bolt nuts indicating possibility of looseness.</p>

**G. Front Axle**

Inspection Procedures:			Repair if:	Recommended Out of Service if:
<p><b>6. Springs</b></p>			<p>One locking pin (draw key) is loose (dual).</p>	<p>Any U-bolt, U-bolt seating plate, shock mount bracket, or nut, is loose, missing, cracked, or stripped.</p>
<p><b>7. King Pins &amp; Bushings.</b></p> <p>Inspect king pin assemblies for condition and play as follows:</p> <p>1) With front wheels raised, grasp tire at top and bottom or using a pry bar for leverage attempt to move the wheel assembly in and out. (fig 6, page 136)</p> <p><b>NOTE: Wheel bearings must be adjusted properly (or wheel bearing play must be eliminated by locking brakes) before checking king pins.</b></p>			<p>End cap O-rings or bolts are loose or missing.</p>	<p>Locking pin (draw key) is backing out, loose (single, both for dual), or missing.</p> <p>Movement at the top or bottom of tire is greater than:</p> <p>Wheel size:          16-inch or less - ¼-inch.          17-18-inch - ⅜-inch.          Over 18-inches - ½-inch.</p>

**E. Front Axle**

Inspection Procedures:			Repair if:	Recommended Out of Service if:
<p><b>7. King Pins &amp; Bushings.</b></p> <p>2) Place a pry bar under wheel and lift tire straight up and down to determine condition of thrust bearing.</p>				<p>Vertical (up and down) play in king pin tire is greater than .030" and/or thrust bearing is damaged or missing. (fig 6, page 136)</p> <p><b>NOTE: If play is beyond specifications, wear may be king pin, axle eye, and/or king pin bushings. Vehicle should be placed out of service if side play at outside edge of tire is greater than ¼-inch. Do not tighten king pin lock (if equipped) or grease king pin before inspecting king pin assembly play.</b></p>
<p><b>8. Wheel Cylinders/Calipers.</b></p> <p>Inspect wheel cylinder(s) or caliper(s) for leaks, mounting, &amp; condition.</p>			<p>Any wheel cylinder or caliper dust boot is damaged or missing.</p>	<p>Any wheel cylinder or caliper is not securely mounted or has loose or missing fasteners.</p> <p>Any wheel cylinder or caliper is leaking.</p>
<p><b>9. Hubs, Drums or Rotors. (as needed)</b></p> <p>a. <b>Drums</b></p> <p>Inspect front brake drum(s) for condition and oversize.</p>				<p>There is uneven lining or pad wear, rotor or drum damage, evidence of dragging, or other evidence that any wheel cylinder or caliper may be sticking.</p>

**E. Front Axle**

Inspection Procedures:			Repair if:	Recommended Out of Service if:
<p><b>9. Hubs, Drums or Rotors. (as needed)</b></p>				<p>There is any crack (other than heat checks) in any drum.            There is more than .060-inch wear in drum friction surface (inside diameter is more than .120-inch over original).</p> <p>There is any grease, oil, or brake fluid on inside of drum.</p> <p>Drum is not mounted to the hub, or fasteners are loose.</p> <p>Drum is not centered on hub (if equipped) causing more than .010-inch out of round.</p>
<p><b>b. Rotors</b></p> <p>Inspect front brake rotor(s) for mounting, thickness, and condition.</p>				<p>Rotor mounting is not secure.</p> <p>Rotor has cracks (other than heat checks) or other mechanical defects.</p> <p>Friction surface is contaminated with oil, grease, or brake fluid.</p>



**E. Front Axle**

Inspection Procedures:			Repair if:	Recommended Out of Service if:
<p><b>9. Hubs, Drums or Rotors. (as needed)</b></p>				<p>Any rotor friction surface is significantly grooved or damaged.</p> <p>Rotor thickness is less than manufacturer's specifications stamped on rotor.</p>
<p><b>10. Wheel Bearings.</b></p> <p>Inspect front wheel bearings and related components for condition and proper adjustment of bearings. With front wheels raised (wheels unloaded), grasp tire and attempt to rock wheel to check for movement. Spin tire to check for noise and condition of bearings.</p>			<p>There is minor seepage of oil or grease around dust cover.</p> <p>Dust covers fasteners are missing or loose.</p>	<p>There is dripping of oil or grease around dust covers or dust covers are damaged or missing.</p> <p>Any noise, binding, or roughness is discovered in bearings. Wheel bearing, end play exceeds manufacturer's specifications (maximum of .010" in and out play measured at bearing hub).</p>

**E. Front Axle**

Inspection Procedures:			Repair if:	Recommended Out of Service if:
<p><b>10. Wheel Bearings.</b></p> <p>NOTE: It is important to correctly identify the source of any play. To determine if the play is in wheel bearings, have an assistant fully apply brakes while rechecking play. If movement disappears with brakes applied, then play was in wheel bearings.</p>				
<p><b>11. Wheel Balance.</b></p> <p>As necessary.</p>				
<p><b>12. Alignment</b></p> <p>Inspect tires for evidence of proper alignment.</p>			<p>Any tire is feather-edged, cupped, or has uneven tread wear.</p> <p>Lateral run out of any tire/rim assembly exceeds ¼-inch.</p>	<p>Tires/wheels are grossly misaligned, affecting steering control.</p>

**F. Rear Axle**

Inspection Procedures:			Repair if:	Recommended Out of Service if:
<p><b>1. Fluid leaks.</b></p> <p>Check for leaks at wheel seals, backing plates, pinion seal, differential and cover.</p>			<p>Differential gasket or pinion seal is seeping.</p>	<p>Differential gaskets or pinion seals are leaking.</p>
<p><b>2. Vent</b></p> <p>Inspect condition of axle housing vent.</p>			<p>Vent cap is clogged.</p> <p>Vent hose (if originally equipped) is cracked, clogged, or missing.</p>	<p>Axle vent is not functional or is missing.</p>
<p><b>3. Shock Absorbers.</b></p> <p>Inspect rear shocks for condition and securement.</p>			<p>There is any wetness around shock body due to leaking shock fluid.</p>	<p>Any shock is broken.</p> <p>Any shock fails to function.</p> <p>Any shock mounting or fastener is loose, missing, cracked, or broken.</p>

**F. Rear Axle**

Inspection Procedures:		Repair if:	Recommended Out of Service if:
<p><b>4. Brake Lining.</b></p> <p>Inspect linings and foundation brake hardware for contamination, wear, damage, and securement.</p>		<p>Lining wear is extremely uneven left and right.</p> <p>Rear brake lining is less than 5/16-inch thick at center of shoe (on brake blocks with original 3/4-inch thickness).</p>	<p>Rear brake lining is less than 1/4-inch thick at center of shoe (on brake blocks with original 3/4 -inch thickness).</p> <p>Rear brake lining is worn to within 1/16-inch of any rivet or bolt head.</p> <p>For bonded linings, rear brake lining is worn to within 1/16-inch of shoe table (at center of shoe).</p> <p>Any foundation brake assembly does not have at least one (1) lining inspection hole.</p> <p>Lining is broken, cracked, or loose on shoe.</p> <p>Friction surface is contaminated with oil, grease, or brake fluid.</p> <p>There is any shimming material between lining and shoe.</p> <p>Lining is not proper size.</p> <p>Shoe platform or webbing is cracked or damaged.</p>

**F. Rear Axle**

Inspection Procedures:		Repair if:	Recommended Out of Service if:
<b>4. Braking Lining.</b>			There is any loose, damaged, or missing foundation brake hardware within the drum.
<b>5. Slack Adjusters.</b>  Inspect slack adjusters and S-cam assemblies for wear, condition, operation, and securement.		Slack adjuster is mounted so that adjuster bolt is facing chamber.	Any portion of slack adjuster or S-cam is missing, broken, cracked, or badly worn.  S-cam shaft and/or S-cam bushing total wear (up and down) is greater than .030" (fig 5, page 135)  S-cam in and out end play is more than .060 inch (fig 5, page 135). S-cam snap ring is missing.  Slack adjuster has frozen or stripped worm gear or ratchet assembly.
<b>6. Springs</b>  Inspect rear springs for condition, securement, and alignment.		There are any loose, missing, broken, or worn spring clips (note).  Any leaf spring or air suspension ride height is less than manufacturer's specifications.	Any leaf spring is broken, cracked or missing.

**F. Rear Axle**

Inspection Procedures:			Repair if:	Recommended Out of Service if:
<p><b>6. Springs</b></p>			<p>Missing insulators between leafs.</p> <p>Either rear spring saddle (if equipped) is worn out or missing.</p> <p>Rubber frame bumper is missing.</p> <p>Any coil or leaf spring has weakened, and vehicle is leaning excessively.</p> <p>Ride height not adjusted properly (air suspension).</p>	<p>On any air bag type spring assembly, air bag is damaged or leaking, or air lines and valves are damaged or leaking.</p> <p>Air ride pivot pins and bushings are loose.</p> <p>There is any misalignment of spring leaves or other evidence that centering pin is loose or broken.</p> <p>Either rear leaf spring is worn to the point that suspension bottoming has damaged rubber frame bumper.</p>
<p><b>a. U-Bolts</b></p> <p>Inspect spring U-bolts for condition and securement.</p>			<p>Any U-bolt is misaligned.</p>	<p>There is rust underneath U-bolt nuts indicating possibility of looseness.</p> <p>Any U-bolt, U-bolt seating plate, shock mount bracket, or nut, is loose, missing, cracked, or stripped.</p>

**F. Rear Axle**

Inspection Procedures:			Repair if:	Recommended Out of Service if:
<p><b>7. Wheel</b></p> <p><b>Cylinders/Calipers.</b></p> <p>Inspect wheel cylinder(s) or caliper(s) for leaks, mounting, and condition.</p>			<p>Any wheel cylinder or caliper dust boot is damaged or missing.</p>	<p>Any wheel cylinder or caliper is not securely mounted or has loose or missing fasteners.</p> <p>Any wheel cylinder or caliper is leaking.</p>
<p><b>8. Hubs, Drums or Rotors</b> <b>(as needed)</b></p> <p><b>a. Drums</b></p> <p>Inspect front brake drum(s) for condition and oversize.</p>				<p>There is uneven lining or pad wear, rotor or drum damage, evidence of dragging, or other evidence that any wheel cylinder or caliper may be sticking.</p> <p>There is any crack (other than heat checks) in any drum.</p> <p>There is more than .060-inch wear in drum friction surface (inside diameter is more than .120-inch over original).</p>

**H. Rear Axle**

Inspection Procedures:			Repair if:	Recommended Out of Service if:
<p><b>8. Hubs, Drums or Rotors (as needed)</b></p>				<p>There is any grease, oil, or brake fluid on inside of drum.</p> <p>Drum is not mounted to the hub, or fasteners are loose.</p> <p>Drum is not centered on hub (if equipped) causing more than .010-inch out of round.</p>
<p><b>b. Rotors</b></p> <p>Inspect front brake rotor(s) for mounting, thickness, and condition.</p>				<p>Rotor mounting is not secure.</p> <p>Rotor has cracks (other than heat checks) or other mechanical defects.</p> <p>Friction surface is contaminated with oil, grease, or brake fluid.</p> <p>Any rotor friction surface is significantly grooved or damaged.</p>



**F. Rear Axle**

Inspection Procedures:			Repair if:	Recommended Out of Service if:
<p><b>8. Hubs, Drums or Rotors (as needed)</b></p>				<p>Rotor thickness is less than manufacturer's specifications stamped on rotor.</p>
<p><b>9. Wheel Bearings</b></p> <p>Inspect rear wheel bearings for condition and proper adjustment of bearings.</p> <p>a) Raised rear wheels (wheels unloaded), and release park brake.</p> <p>b) Grasp tire and attempt to rock wheel to check for movement.</p>				<p>There is any detectable looseness or roughness in rear wheel bearings.</p>
<p><b>10. Wheel Seals</b></p> <p>Inspect rear wheel seals for condition and leakage.</p>			<p>There is wetness or dripping of oil or grease around axle flange.</p>	<p>Either rear wheel seal is damaged or leaking excessively.</p> <p>Any axle flange stud or nut is loose or missing.</p>

**G. Under Bus**

Inspection Procedures:			Repair if:	Recommended Out of Service if:
<p><b>1. Exhaust Systems.</b></p> <p><b>a. Exhaust Leaks</b></p> <p>With engine running and at operating temperature, inspect exhaust system for leaks, condition, and securement.</p>			<p>Any exhaust junction gasket or hardware is broken or missing.</p> <p>There is any physical damage to exhaust system (note).</p>	<p>There is any leakage, which is audible or can be felt around any portion of the exhaust system including manifold(s), pipe sections, or any junction.</p>
<p><b>b. Mounting</b></p> <p>Inspect mounting of the exhaust system.</p>			<p>There is any exhaust system hanger, which is not securely mounted.</p> <p>Any exhaust pipe or clamp is loose.</p>	<p>There is any originally installed exhaust hanger, which is missing, broken, or detached from exhaust system or frame mounting point.</p> <p>Clamp is missing.</p>

**G. Under Bus**

Inspection Procedures:			Repair if:	Recommended Out of Service if:
<p><b>1. Exhaust System.</b></p> <p><b>c. Muffler.</b></p> <p>Inspect condition of the muffler.</p>			<p>There is other significant physical damage to the muffler (note).</p> <p>The muffler is cracked.</p>	<p>The muffler is leaking.</p>
<p><b>d. Tailpipe.</b></p> <p>Inspect condition of the tailpipe.</p>			<p>The tailpipe is cracked.</p> <p>There is other significant physical damage to the tailpipe.</p>	<p>The tailpipe is leaking.</p> <p>The tailpipe does not extend at least to the rear edge of the rear bumper, but not more than 2-inches beyond bumper or does not exit to the left of the left frame rail.</p> <p>Tailpipe opening is mashed or pinched.</p>
<p><b>2. Clutch.</b></p> <p><b>A. Operation-</b></p> <p>1) Check pedal, linkage, clutch, and throw-out bearing for wear, slippage, and abnormal noises in the engaged and released positions.</p>			<p>Loose nuts and bolts.</p> <p>Noisy throw-out bearing (note).</p> <p>Clutch out of adjustment.</p>	<p>Cannot adjust clutch to specs.</p> <p>Excessively noisy throw-out bearing.</p> <p>Clutch slipping, grabbing, or has excessive chatter when engaging clutch.</p>

**G. Under Bus**

Inspection Procedures:			Repair if:	Recommended Out of Service if:
<b>2. Clutch</b>				Binding or sticking clutch linkage or return spring.  Hard to shift transmission.
2) Visually check clutch pedal pad for wear.			Worn pedal cover pad.	Medal pedal cover pad is missing.
3) Check clutch master and slave cylinders for hydraulic leaks and operation (if equipped).				Leaking master or slave cylinder or inoperable.
<b>B. Adjustment</b>  1) Check "free play" travel of the clutch pedal. This is the first easy movement of the clutch pedal and should be no more than 1-1/2-inch and no less than 3/4-inch of travel.			"Free play" is out of adjustment.	Clutch slips, grabs, or chatters after adjusting "free play" travel.  No adjustments can be made.

**G. Under Bus**

Inspection Procedures:			Repair if:	Recommended Out of Service if:
<p><b>3. Air Tanks.</b></p> <p><b>a. Reservoir Mounting.</b></p> <p>Inspect reservoirs (air vacuum tanks) for securement and condition.</p>				<p>Any reservoir mounting strap or fastener is cracked, loose, or missing.</p>
<p><b>b. Bleed Air Reservoir.</b></p> <p>1) With air system fully charged, check manual operation of safety relief valve.</p> <p>2) Partially open manual petcock valve on the first (wet) tank.</p> <p>3) Allow draining until any moisture (water) or contamination is drained.</p>			<p>There is moisture in reservoir (desiccant type air dryer equipped vehicles only).</p>	<p>Safety relief valve leaks or does not release pressure.</p> <p>There is excessive sludge or oil contamination in the reservoir (more than 8-fluid ounces).</p> <p>Reservoir leaks due to corrosion or is cracked.</p> <p>Release valve does not close.</p>

**G. Under Bus**

Inspection Procedures:			Repair if:	Recommended Out of Service if:
<p><b>4. Transmission</b></p> <p><b>a. Transmission Bolts.</b></p> <p>1) Inspect transmission assembly and mounting fasteners for condition and securement.</p>			<p>Any transmission assembly fastener loose, missing or damaged.</p>	<p>Transmission is not mounted securely to flywheel housing.</p> <p>There is any external indication that any torque converter bolt(s) is loose or missing.</p>
<p><b>b. Linkage</b></p> <p>1) Inspect transmission linkage for routing, condition, and securement.</p> <p><b>Note: Mechanical modulator cable should have 1/16- to 1/8-inch clearance at full throttle.</b></p>			<p>Modulator cable or vacuum hose is routed where it is subject to excessive heat or abrasion.</p> <p>Any linkage hardware or fasteners are loose.</p> <p>Modulator cable is exposed or casing is damaged.</p>	<p>Linkage is bent, damaged, binding, or severely misadjusted.</p> <p>Any linkage hardware or fasteners are missing or linkage is damaged so as to cause a sticking or binding condition.</p>

**G. Under Bus**

Inspection Procedures:			Repair if:	Recommended Out of Service if:
<b>4. Transmission</b>			<p>Modulator vacuum hose is deteriorated or loose.</p> <p>Modulator cable is out of adjustment.</p>	<p>Modulator vacuum hose is leaking or not connected.</p> <p>Air modulator or air line leaking.</p>
<p><b>c. Lines</b></p> <p>1) Inspect transmission lines for securement, routing, and condition.</p>			<p>Any transmission line(s) is unsecured or routed subject to excessive heat or abrasion.</p>	<p>Any transmission line is crimped.</p> <p>There is any transmission line of improper type.</p> <p>Any transmission line is worn or deteriorated to the point that failure could occur.</p>

**G. Under Bus**

Inspection Procedures:			Repair if:	Recommended Out of Service if:
<p><b>d. Filter</b></p> <p>1) Inspect transmission external filter assembly (if equipped) for securement and condition.</p>			<p>External filter mounting is insecure or has loose or missing fasteners.</p> <p>Pall filter monitor indicates need for change.</p> <p>Filter canister is damaged with no leak.</p>	
<p><b>e. Cooler</b></p> <p>Inspect transmission cooler (as equipped) for securement and condition.</p>			<p>Mounting of separate transmission cooler (if equipped) is insecure or has loose or missing fasteners.</p>	<p>Body of transmission cooler, including all hose connections, is cracked or damaged.</p>



**G. Under Bus**

Inspection Procedures:			Repair if:	Recommended Out of Service if:
<p><b>5. Parking Brake-Driveshaft (if equipped) .</b></p> <p>1. Inspect driveshaft park brake assembly for condition, mounting, securement, and adjustment of linings, drum, linkage, and all other related hardware.</p>				<p>Lining is worn beyond allowable limit.</p> <p>Lining is contaminated with grease or oil.</p> <p>Lining is broken, cracked, or loose.</p> <p>Drum is cracked or has excessive heat damage or scoring of friction surface.</p> <p>Any actuating or mounting hardware or fastener is damaged, loose, or missing.</p> <p>Park brake is not adjusted per manufacturer's specification.</p>
<p><b>6. Driveline</b></p> <p><b>a. Driveshafts</b></p> <p>1) Inspect driveshafts and damper for condition.</p>				<p>Any driveshaft balancing weight (if originally equipped) is missing.</p>

**G. Under Bus**

Inspection Procedures:			Repair if:	Recommended Out of Service if:
<b>6. Driveline</b>				<p>Any driveshaft is bent or seriously dented.</p> <p>Any loose, damaged, or leaking damper.</p> <p>There are cracks or other damage to driveshaft, which could cause structural failure.</p> <p>There is any foreign matter wrapped around driveshaft.</p>
<p><b>b. U-Joints</b></p> <p>1) Prior to lubrications, inspect U-joints or constant velocity (CV) joints (if equipped) for condition, phasing, (alignment of joints), lubrication and presence of hardware.</p>			<p>Shaft is out of phase.</p> <p>U-joint or constant velocity joints are dry of lubrication, or zerk (grease) fitting (if equipped) is missing, clogged, or inaccessible.</p>	<p>There is any missing hardware or fasteners in any U-joint or CV assembly.</p> <p>Any U-joint has significantly cross-shaft-to-bearing cup play, or CV joint has significant play.</p>
<p><b>c. Yokes</b></p> <p>1) Inspect driveshaft yokes for condition and lubrication.</p>			<p>Driveshaft splines are not lubricated.</p>	<p>Any yoke has significant play in splines.</p>

**G. Under Bus**

Inspection Procedures:		Repair if:	Recommended Out of Service if:
<p><b>6. Driveline</b></p>		<p>Dust cap on yoke is loose or missing.</p> <p>Zerk (grease) fitting is missing or clogged.</p> <p>Packing in dust cap is missing.</p>	<p>Any yoke is cracked or damaged.</p>
<p><b>d. Midshaft (midship) Bearing.</b></p> <p>1) Inspect midshaft (midship) bearings and rubber insulators for condition and securement.</p>		<p>Midshaft (midship) bearing rubber insulator is deteriorated, damaged, or oil soaked.</p> <p>Midshaft (midship) bearing support is misaligned.</p>	<p>Bearing outer race is loose in insulator, or inner race is loose on shaft.</p> <p>There is significant play in midshaft (midship) bearing.</p> <p>There is any missing or damaged hardware or fastener in midshaft (midship) bearing or support assembly.</p>

**G. Under Bus**

Inspection Procedures:			Repair if:	Recommended Out of Service if:
<p><b>6. Driveline</b></p> <p><b>e. Guards</b></p> <p>1) Inspect for presence and condition of drive-shaft guards (if originally equipped).</p>			<p>Any driveshaft guard is bent or damaged (not rubbing).</p>	<p>Any driveshaft guard is missing, or has loose or damaged mounting fasteners or is rubbing shaft.</p>
<p><b>7. Fuel Tanks.</b></p> <p><b>a. Leaks</b></p> <p>1) Inspect fuel tank assembly for leaks.</p>				<p>There is any fuel leakage from the tank, connections, or cap.</p> <p>The fuel tank has any cracks.</p>
<p><b>b. Mounting</b></p> <p>1) Inspect fuel tank mounting system and barrier (if equipped) for securement and condition.</p>				<p>Any portion fuel tank mounting system (including support brackets, retaining straps and chassis frame) is missing, loose, cracked, or broken.</p> <p>Any fuel tank mounting fasteners are loose or missing.</p> <p>Barrier assembly (if equipped) is damaged, insecurely mounted or missing.</p>

**G. Under Bus**

Inspection Procedures:			Repair if:	Recommended Out of Service if:
<b>7. Fuel Tanks</b>				Fuel tank is not O.E.M, been modified or extra tank(s) have been added.
<p><b>c. Hoses</b></p> <p>1) Inspect all fuel lines, hoses and under bus fuel system components, for routing, securement and condition (including vents, fill and crossover).</p>				<p>Any fuel line or hose is unsecured or is routed subject to excessive heat or abrasion.</p> <p>Any fuel line or hose is deteriorated or damaged (including cracks or any damage which may cause potential leakage) or clamps are loose or missing.</p> <p>Any under-bus fuel system filter, water separator or other components are insecurely mounted, cracked or damaged.</p>
<p><b>d. Wiring</b></p> <p>1) Inspect fuel tank sender unit wiring for securement, routing and condition.</p>			Any portion of sending unit wiring (including ground) or connection is unsecured or routed subject to excessive heat or abrasion.	Any wiring or connection has damaged or missing insulation.

**G. Under Bus**

Inspection Procedures:			Repair if:	Recommended Out of Service if:
<p><b>7. Fuel Tanks</b></p> <p>2) Inspect electric fuel pump wiring for securement, routing and condition.</p>				<p>Any portion of fuel pump wiring (including ground) or connection unsecured or is routed subject to heat or abrasion.</p>
<p><b>8. Air Dryer</b></p> <p>1) Check dryer for securement and condition.</p>			<p>Dryer has loose or missing mounting bolts but not in danger of falling off.</p> <p>Canister portion of dryer is bent or damaged but is not leaking or loose.</p>	<p>Dryer has loose or missing mounting bolts and is in danger of falling off.</p> <p>Canister portion or dryer is bent or damaged and is leaking or loose.</p>
<p>2) Check dryer fitting, plumbing and connections.</p>			<p>Electrical connection for heating element loose or damaged.</p> <p>Air line to dryer has a loop or low spot (sump) that can collect water and freeze.</p>	<p>Any air line connection is loose or has an audible leak.</p>

**G. Under Bus**

Inspection Procedures:		Repair if:	Recommended Out of Service if:
<p><b>8. Air Dryer.</b></p> <p>3) Check purge valve for operation and contamination.</p> <p><b>Note: There may be dampness and oil residue on and around valve. A slight leak is acceptable from valve during charging cycle or if shut down prior purge cycle.</b></p>			<p>Valve is contaminated by solid material (desiccant, cloth, rubber, metal, etc.), which would prevent it from seating.</p> <p>Valve continues to leak after purge cycle.</p>
<p><b>9. Brake Chambers.</b></p> <p>1) Inspect brake chamber assembly(ies) for securement, condition and proper size.</p>		<p>Any missing or damaged spring brake caging bolts.</p>	<p>Any brake chamber mounting bracket is cracked, bent or broken.</p> <p>Any brake chamber or mounting fastener is damaged or loose.</p> <p>Any brake chamber is not original size or size of chambers is not matched left and right (Both sides same size).</p> <p>Any leak is detected in chamber.</p>

**G. Under Bus**

Inspection Procedures:			Repair if:	Recommended Out of Service if:
<p><b>9. Brake Chambers.</b></p>				<p>Any wear to chamber or rod (where rod exits chamber).</p> <p>Any spring brake chamber is bent, damaged or corroded and may lose containment of spring.</p>
<p><b>10. Frame and Crossmember.</b></p> <p>1) Check frame rails, extensions, modular sections, cross-members, braces, gussets, liners and all fasteners for damage, condition and mounting.</p>				<p>Frame, frame braces and associated rivets or fasteners are loose, damaged or missing.</p> <p>Frame, extensions, liners or modular sections are damaged, cracked or broken.</p> <p>Frame braces or cross-members are damaged, cracked or broken.</p> <p>Rivets or other fasteners at frame braces or cross members are loose or missing.</p> <p>Any axle or suspension component is loose beyond specifications.</p> <p>Any unauthorized modifications.</p>



## PROCEDURE FOR MEASURING PUSH ROD TRAVEL

Brake chamber push rod travel shall not exceed those specifications relating to maximum stroke at which brakes should be readjusted. Performance of the brake push rod travel inspection should be done with the brake application air pressure in the range of 80 - 90 -psi., when measuring total stroke to determine proper brake adjustment.

**CAUTION:** Chock wheels before commencing this inspection as vehicle emergency brake(s) must be off.

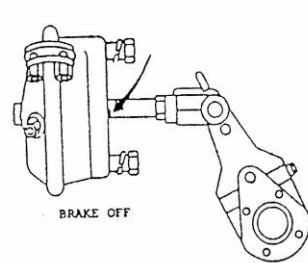

With brakes off, mark push rod at chamber

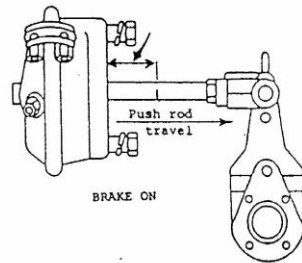

Apply brakes, measure distance of mark from chamber

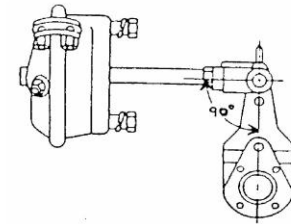

Note: When brakes are properly adjusted and full applied, the slack adjuster should be at an angle of 90° or greater, measured from center line of adjuster to push rod.

**Clamp Type Brake Chamber**  
(Dimensions in Inches)

Type	Maximum Stroke	Maximum stroke with brakes adjusted	Maximum stroke at which Brakes should be adjusted
6	1-5/8	Should	1-1/4
9	1-3/4	be as	1-3/8
12	1-3/4	short as	1-3/8
16	2-1/4	possible	1-3/4
20	2-1/4	without	1-3/4
24	2-1/4	brakes	1-3/4
30	2-1/2	dragging	2
36	3		2-1/4

**Rotor Chamber**  
(Dimensions in Inches)

9	2	Should	1-5/8
12	2	be as	1-5/8
16	2-1/2	short as	2
20	2-1/2	possible	2
24	2-1/2	without	2
30	3	brakes	2-1/2
36	3-1/2	dragging	2-3/4
50	4		3-1/4

**Air Disc Brakes**  
(Dimensions in Inches)

12	1-3/8	Should be as	1-3/8
16	1-1/2	short as	1-3/4
20	1-5/8	possible without	1-3/4
24	1-3/4	brakes	1-3/4
30	1-7/8	dragging	2

## CHECKING BELT TENSION AFTER TIGHTENING

Figure 1 - Checking Belt Tension  
Measuring Belt Tension Gauge Method Rule Method

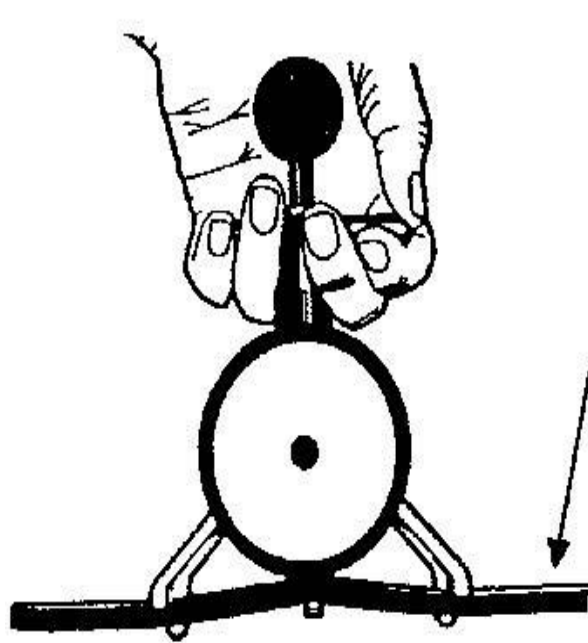

Figure 2 -

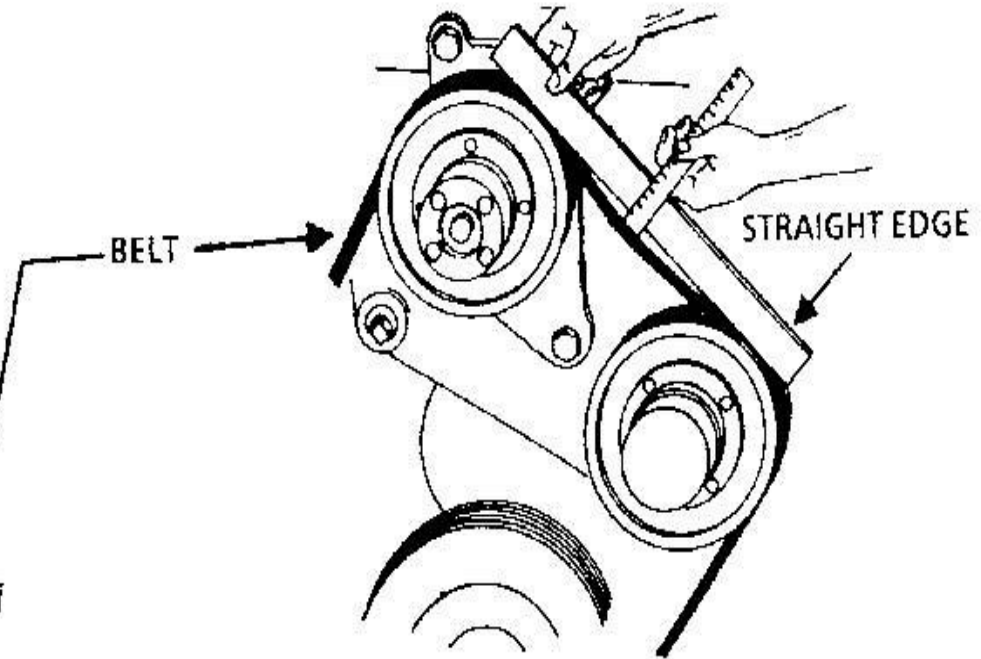

Figure 4 - Checking Idler Movement

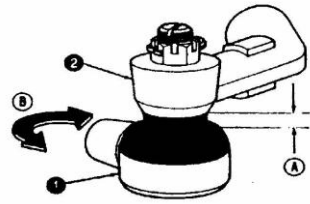
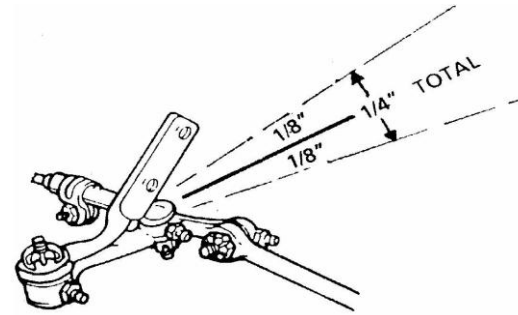

Figure 3- Checking the rod and

Drag link end movement



- A. Movement in the axial direction must be less than 1/16 inch.
- B. Tie rod/drag link free to rotate within steering arm socket.
  - 1. Tie rod/drag link end
  - 2. Steering arm

Figure 5

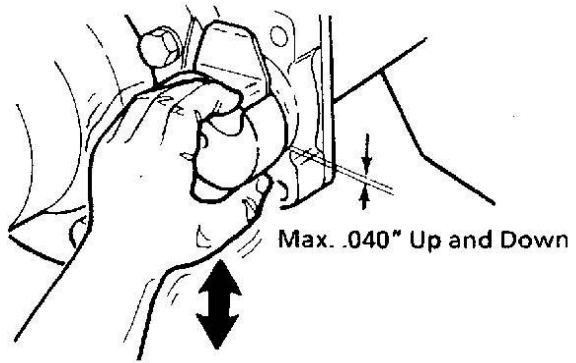

S-cam bushing up and down play

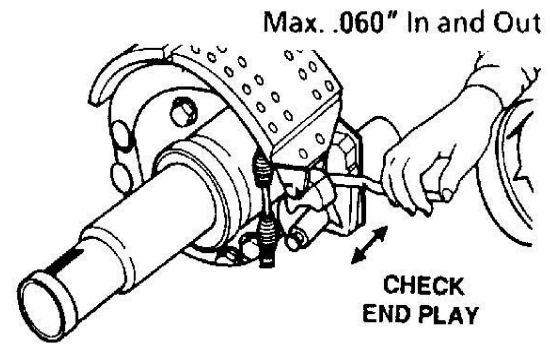

S-cam bushing in and out play

Figure 6 King Pin Bushing Wear Check

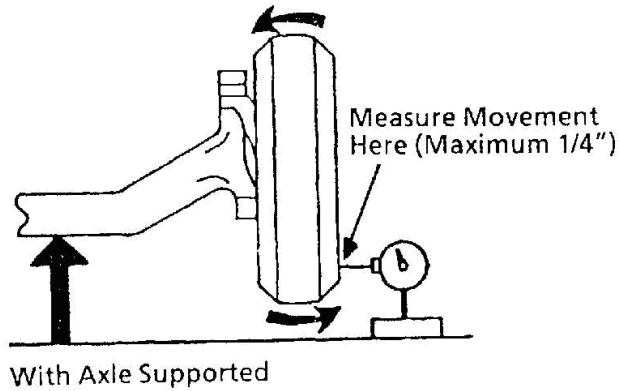

Figure 7 Spindle Thrust Bearing Check

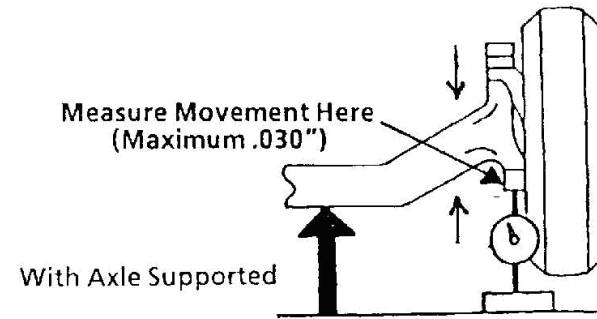
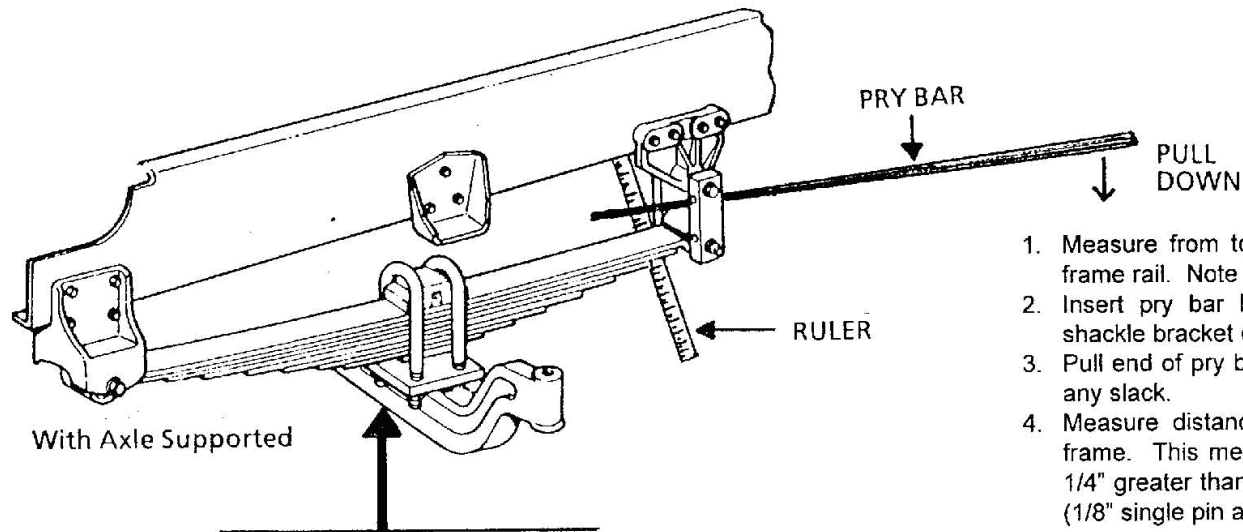

Figure 8 Front Spring Shackle Pin Bushing Play Check



1. Measure from top of spring leaf to bottom of frame rail. Note distance.
2. Insert pry bar between spring eye end and shackle bracket or frame.
3. Pull end of pry bar down sufficiently to take up any slack.
4. Measure distance again between spring and frame. This measurement should not be over 1/4" greater than measurement taken in step 1 (1/8" single pin and bushing type).



### **SECTION III**

## **SHOP RECORDS AND INVENTORY CONTROL**

Adequate record keeping is essential to a preventive maintenance program. Maintenance records enable fleet management personnel to plan for and schedule needed maintenance work. Accurate records may also be needed to support warranty claims or to provide information for accident investigations. Even more important, well kept maintenance records can be used by management personnel to monitor the maintenance program and determine its effectiveness.

Among the documents to be included in a vehicle maintenance file are the mechanic's inspection and a copy of repair orders indicating the repairs performed and routine work such as lubrication, oil, and filter change. The bus make, model, serial number, line set ticket, and tire information should also be included. Records should be retained according to the Library of Virginia's General Schedules for Virginia Localities.

Sample forms included show information a school division should maintain on a school bus.

Work or repair orders are used to aid personnel in performing necessary repairs and service and in providing adequate maintenance and cost records for each school bus. The orders serve as a means of comparing parts used to parts in stock or purchased. Retention of these orders makes it possible to maintain a complete history of all repairs and service performed on each bus. The orders should contain all pertinent information and be retained for the life of the bus. All labor costs must be included on repair orders to provide accurate cost accounting.

Inventory records are essential in stocking items. These records also provide a means of controlling inventory so as to ensure that parts are being used on authorized vehicles. It is imperative that all items taken out of inventory appear on a repair order so that they can be charged to the proper vehicle.

Today many school divisions are using automated systems to track maintenance and repairs on school buses. These automated systems are encouraged and are used to track inventory and other pertinent information about the school bus maintenance area.

Computer systems used for maintenance management can track valuable data and show any trends regarding specific activities, including the following information, tracked by both vehicle and by fleet:

- Cost of repairs - parts and labor

- Fuel consumption and fuel cost

- Total operational cost

- Historical data of inspection and repairs

- Historical data of all expenditures

- Bus data base by manufacturer, year, body type, etc.

- Personnel information, timekeeping, payroll, etc.

## School Bus Garage Repair Order

Division	Year	Date
Driver	Model	Mileage
Body	Chassis	Model

Acct	Qty	Part #	Description	Price	Oper. No.	Instructions	Labor Charges

Gas	<input style="width: 100%;" type="text"/>	Total Labor	<input style="width: 100%;" type="text"/>
Oil, Qts.	<input style="width: 100%;" type="text"/>	Total Parts	<input style="width: 100%;" type="text"/>
Grease, Lbs.	<input style="width: 100%;" type="text"/>	Accessories	<input style="width: 100%;" type="text"/>
Misc.	<input style="width: 100%;" type="text"/>	Gas, Oil, Grease	<input style="width: 100%;" type="text"/>
		Outside Repairs	<input style="width: 100%;" type="text"/>
		Tax	<input style="width: 100%;" type="text"/>
Total	<input style="width: 100%;" type="text"/>	Total Amount	<input style="width: 100%;" type="text"/>





**MONTHLY INVENTORY OF TIRES, BATTERIES, ANTIFREEZE  
LUBRICANTS, AND FLUIDS**

School Division \_\_\_\_\_ Month \_\_\_\_\_ Year \_\_\_\_\_

**TIRES**

	Size	Cost	Size	Cost	Size	Cost	Size	Cost
# Start Month								
# Used Month								
# Purchased								
# Month End								

**BATTERIES**

	Size	Cost	Size	Cost	Size	Cost	Size	Cost
# Start Month								
# Used Month								
# Purchased								
# Month End								

**ANTIFREEZE**

	Gallons	Cost	Gallons	Cost	Gallons	Cost	Gallons	Cost
# Start Month								
# Used Month								
# Purchased								
# Month End								

### LUBRICANTS AND FLUIDS

	Grease		Gear Oil		P/S Fluid		Brake Fluid	
	Gallons	Cost	Gallons	Cost	Gallons	Cost	Gallons	Cost
# Start Month								
# Used Month								
# Purchased								
# Month End								

	W/W Fluid		Hyd Fluid	
	Gallons	Cost	Gallons	Cost
# Start Month				
# Used Month				
# Purchased				
# Month End				

Signature of Person Taking Inventory \_\_\_\_\_ Date \_\_\_\_\_







