



Methods for the Determination of Organic Compounds in Drinking Water

Supplement III

(WITH ERRATA SHEETS)



EPA-600/R-95/131
AUGUST 1995

METHODS FOR THE DETERMINATION
OF ORGANIC COMPOUNDS
IN DRINKING WATER
SUPPLEMENT III

(WITH ERRATA SHEETS)

NATIONAL EXPOSURE RESEARCH LABORATORY
OFFICE OF RESEARCH AND DEVELOPMENT
U.S. ENVIRONMENTAL PROTECTION AGENCY
CINCINNATI, OHIO 45268



Printed on Recycled Paper

METHOD 525.2

**DETERMINATION OF ORGANIC COMPOUNDS IN DRINKING WATER BY
LIQUID-SOLID EXTRACTION AND CAPILLARY COLUMN GAS
CHROMATOGRAPHY/MASS SPECTROMETRY**

Revision 2.0

J.W. Eichelberger, T.D. Behymer, W.L. Budde - Method 525,
Revision 1.0, 2.0, 2.1 (1988)

J.W. Eichelberger, T.D. Behymer, and W.L. Budde - Method 525.1
Revision 2.2 (July 1991)

J.W. Eichelberger, J.W. Munch, and J.A. Shoemaker
Method 525.2 Revision 1.0 (February, 1994)

J.W. Munch - Method 525.2, Revision 2.0 (1995)

**NATIONAL EXPOSURE RESEARCH LABORATORY
OFFICE OF RESEARCH AND DEVELOPMENT
U.S. ENVIRONMENTAL PROTECTION AGENCY
CINCINNATI, OHIO 45268**

METHOD 525.2

DETERMINATION OF ORGANIC COMPOUNDS IN DRINKING WATER BY LIQUID-SOLID EXTRACTION AND CAPILLARY COLUMN GAS CHROMATOGRAPHY/MASS SPECTROMETRY

1.0 SCOPE AND APPLICATION

- 1.1 This is a general purpose method that provides procedures for determination of organic compounds in finished drinking water, source water, or drinking water in any treatment stage. The method is applicable to a wide range of organic compounds that are efficiently partitioned from the water sample onto a C₁₈ organic phase chemically bonded to a solid matrix in a disk or cartridge, and sufficiently volatile and thermally stable for gas chromatography. Single-laboratory accuracy and precision data have been determined with two instrument systems using both disks and cartridges for most of the following compounds:

Analyte	MW ¹	Chemical Abstract Services Registry Number
Acenaphthylene	152	208-96-8
Alachlor	269	15972-60-8
Aldrin	362	309-00-2
Ametryn	227	834-12-8
Anthracene	178	120-12-7
Atraton	211	1610-17-9
Atrazine	215	1912-24-9
Benz[a]anthracene	228	56-55-3
Benzo[b]fluoranthene	252	205-82-3
Benzo[k]fluoranthene	252	207-08-9
Benzo[a]pyrene	252	50-32-8
Benzo[g,h,i]perylene	276	191-24-2
Bromacil	260	314-40-9
Butachlor	311	23184-66-9
Butylate	317	2008-41-5
Butylbenzylphthalate	312	85-68-7
Carboxin ²	235	5234-68-4
Chlordane components		
alpha-Chlordane	406	5103-71-9
gamma-Chlordane	406	5103-74-2
trans-Nonachlor	440	39765-80-5
Chlorneb	206	2675-77-6
Chlorobenzilate	324	510-15-6
Chlorpropham	213	101-21-3
Chlorothalonil	264	1897-45-6

Analyte	MW ¹	Chemical Abstract Services Registry Number
Chlorpyrifos	349	2921-88-2
2-Chlorobiphenyl	188	2051-60-7
Chrysene	228	218-01-9
Cyanazine	240	21725-46-2
Cycloate	215	1134-23-2
Dacthal (DCPA)	330	1861-32-1
4,4'-DDD	318	72-54-8
4,4'-DDE	316	72-55-9
4,4'-DDT	352	50-29-3
Diazinon ²	304	333-41-5
Dibenz[a,h]anthracene	278	53-70-3
Di-n-Butylphthalate	278	84-74-2
2,3-Dichlorobiphenyl	222	16605-91-7
Dichlorvos	220	62-73-7
Dieldrin	378	60-57-1
Diethylphthalate	222	84-66-2
Di(2-ethylhexyl)adipate	370	103-23-1
Di(2-ethylhexyl)phthalate	390	117-81-7
Dimethylphthalate	194	131-11-3
2,4-Dinitrotoluene	182	121-14-2
2,6-Dinitrotoluene	182	606-20-2
Diphenamid	239	957-51-7
Disulfoton ²	274	298-04-4
Disulfoton Sulfoxide ²	290	2497-07-6
Disulfoton Sulfone	306	2497-06-5
Endosulfan I	404	959-98-8
Endosulfan II	404	33213-65-9
Endosulfan Sulfate	420	1031-07-8
Endrin	378	72-20-8
Endrin Aldehyde	378	7421-93-4
EPTC	189	759-94-4
Ethoprop	242	13194-48-4
Etridiazole	246	2593-15-9
Fenamiphos ²	303	22224-92-6
Fenarimol	330	60168-88-9
Fluorene	166	86-73-7
Fluridone	328	59756-60-4
Heptachlor	370	76-44-8
Heptachlor Epoxide	386	1024-57-3
2,2', 3,3', 4,4', 6-Heptachloro- biphenyl	392	52663-71-5
Hexachlorobenzene	282	118-74-1
2,2', 4,4', 5,6'-Hexachloro- biphenyl	358	60145-22-4

Analyte	MW ¹	Chemical Abstract Services Registry Number
Hexachlorocyclohexane, alpha	288	319-84-6
Hexachlorocyclohexane, beta	288	319-85-7
Hexachlorocyclohexane, delta	288	319-86-8
Hexachlorocyclopentadiene	270	77-47-4
Hexazinone	252	51235-04-2
Indeno[1,2,3,c,d]pyrene	276	193-39-5
Isophorone	138	78-59-1
Lindane	288	58-89-9
Merphos ²	298	150-50-5
Methoxychlor	344	72-43-5
Methyl Paraoxon	247	950-35-6
Metolachlor	283	51218-45-2
Metribuzin	214	21087-64-9
Mevinphos	224	7786-34-7
MGK 264	275	113-48-4
Molinate	187	2212-67-1
Napropamide	271	15299-99-7
Norflurazon	303	27314-13-2
2,2', 3,3', 4,5', 6,6'-Octachloro- biphenyl	426	40186-71-8
Pebulate	203	1114-71-2
2,2', 3', 4,6'-Pentachlorobiphenyl	324	60233-25-2
Pentachlorophenol	264	87-86-5
Phenanthrene	178	85-01-8
cis-Permethrin	390	54774-45-7
trans-Permethrin	390	51877-74-8
Prometon	225	1610-18-0
Prometryn	241	7287-19-6
Pronamide	255	23950-58-5
Propachlor	211	1918-16-7
Propazine	229	139-40-2
Pyrene	202	129-00-0
Simazine	201	122-34-9
Simetryn	213	1014-70-6
Stirofos	364	22248-79-9
Tebuthiuron	228	34014-18-1
Terbacil	216	5902-51-2
Terbufos2	288	13071-79-9
Terbutryn	241	886-50-0
2,2', 4,4'-Tetrachlorobiphenyl	290	2437-79-8
Toxaphene		8001-35-2
Triademefon	293	43121-43-3
2,4,5-Trichlorobiphenyl	256	15862-07-4
Tricyclazole	189	41814-78-2

Analyte	MW ¹	Chemical Abstract Services Registry Number
Trifluralin	335	1582-09-8
Vernolate	203	1929-77-7
Aroclor 1016		12674-11-2
Aroclor 1221		11104-28-2
Aroclor 1232		11141-16-5
Aroclor 1242		53469-21-9
Aroclor 1248		12672-29-6
Aroclor 1254		11097-69-1
Aroclor 1260		11096-82-5

¹Monoisotopic molecular weight calculated from the atomic masses of the isotopes with the smallest masses.

²Only qualitative identification of these analytes is possible because of their instability in aqueous matrices. Merphos, carboxin, disulfoton, and disulfoton sulfoxide showed instability within 1 h of fortification. Diazinon, fenamiphos, and terbufos showed significant losses within seven days under the sample storage conditions specified in this method.

Attempting to determine all of the above analytes in all samples is not practical and not necessary in most cases. If all the analytes must be determined, multiple calibration mixtures will be required.

- 1.2 Method detection limit (MDL) is defined as the statistically calculated minimum amount that can be measured with 99% confidence that the reported value is greater than zero¹. The MDL is compound dependent and is particularly dependent on extraction efficiency and sample matrix. MDLs for all method analytes are listed in Tables 3 through 6. The concentration calibration range demonstrated in this method is 0.1-10 µg/L for most analytes.

2.0 SUMMARY OF METHOD

Organic compound analytes, internal standards, and surrogates are extracted from a water sample by passing 1 L of sample water through a cartridge or disk containing a solid matrix with a chemically bonded C₁₈ organic phase (liquid-solid extraction, LSE). The organic compounds are eluted from the LSE cartridge or disk with small quantities of ethyl acetate followed by methylene chloride, and this extract is concentrated further by evaporation of some of the solvent. The sample components are separated, identified, and measured by injecting an aliquot of the concentrated extract into a high resolution fused silica capillary column of a gas chromatography/mass spectrometry (GC/MS) system. Compounds eluting from the GC column are identified by comparing their measured mass spectra and retention times to reference spectra and retention times in a data base. Reference spectra and retention times for analytes are obtained by the measurement of calibration standards under the same conditions used for samples.

The concentration of each identified component is measured by relating the MS response of the quantitation ion produced by that compound to the MS response of the quantitation ion produced by a compound that is used as an internal standard. Surrogate analytes, whose concentrations are known in every sample, are measured with the same internal standard calibration procedure.

3.0 DEFINITIONS

- 3.1 Internal Standard (IS) -- A pure analyte(s) added to a sample, extract, or standard solution in known amount(s) and used to measure the relative responses of other method analytes and surrogates that are components of the same solution. The internal standard must be an analyte that is not a sample component.
- 3.2 Surrogate Analyte (SA) -- A pure analyte(s), which is extremely unlikely to be found in any sample, and which is added to a sample aliquot in known amount(s) before extraction or other processing, and is measured with the same procedures used to measure other sample components. The purpose of the SA is to monitor method performance with each sample.
- 3.3 Laboratory Duplicates (LD1 and LD2) -- Two aliquots of the same sample taken in the laboratory and analyzed separately with identical procedures. Analyses of LD1 and LD2 indicate precision associated with laboratory procedures, but not with sample collection, preservation, or storage procedures.
- 3.4 Field Duplicates (FD1 and FD2) -- Two separate samples collected at the same time and place under identical circumstances, and treated exactly the same throughout field and laboratory procedures. Analyses of FD1 and FD2 give a measure of the precision associated with sample collection, preservation, and storage, as well as with laboratory procedures.
- 3.5 Laboratory Reagent Blank (LRB) -- An aliquot of reagent water or other blank matrix that is treated exactly as a sample including exposure to all glassware, equipment, solvents, reagents, internal standards, and surrogates that are used with other samples. The LRB is used to determine if method analytes or other interferences are present in the laboratory environment, the reagents, or the apparatus.
- 3.6 Field Reagent Blank (FRB) -- An aliquot of reagent water or other blank matrix that is placed in a sample container in the laboratory and treated as a sample in all respects, including shipment to the sampling site, exposure to sampling site conditions, storage, preservation, and all analytical procedures. The purpose of the FRB is to determine if method analytes or other interferences are present in the field environment.

- 3.7 Instrument Performance Check Solution (IPC) -- A solution of one or more method analytes, surrogates, internal standards, or other test substances used to evaluate the performance of the instrument system with respect to a defined set of method criteria.
- 3.8 Laboratory Fortified Blank (LFB) -- An aliquot of reagent water or other blank matrix to which known quantities of the method analytes are added in the laboratory. The LFB is analyzed exactly like a sample, and its purpose is to determine whether the methodology is in control, and whether the laboratory is capable of making accurate and precise measurements.
- 3.9 Laboratory Fortified Sample Matrix (LFM) -- An aliquot of an environmental sample to which known quantities of the method analytes are added in the laboratory. The LFM is analyzed exactly like a sample, and its purpose is to determine whether the sample matrix contributes bias to the analytical results. The background concentrations of the analytes in the sample matrix must be determined in a separate aliquot and the measured values in the LFM corrected for background concentrations.
- 3.10 Stock Standard Solution (SSS) -- A concentrated solution containing one or more method analytes prepared in the laboratory using assayed reference materials or purchased from a reputable commercial source.
- 3.11 Primary Dilution Standard Solution (PDS) -- A solution of several analytes prepared in the laboratory from stock standard solutions and diluted as needed to prepare calibration solutions and other needed analyte solutions.
- 3.12 Calibration Standard (CAL) -- A solution prepared from the primary dilution standard solution or stock standard solutions and the internal standards and surrogate analytes. The CAL solutions are used to calibrate the instrument response with respect to analyte concentration.
- 3.13 Quality Control Sample (QCS) -- A solution of method analytes of known concentrations which is used to fortify an aliquot of LRB or sample matrix. The QCS is obtained from a source external to the laboratory and different from the source of calibration standards. It is used to check laboratory performance with externally prepared test materials.

4.0 INTERFERENCES

- 4.1 During analysis, major contaminant sources are reagents and liquid- solid extraction devices. Analyses of field and laboratory reagent blanks provide information about the presence of contaminants.

- 4.2 Interfering contamination may occur when a sample containing low concentrations of compounds is analyzed immediately after a sample containing relatively high concentrations of compounds. Syringes and splitless injection port liners must be cleaned carefully or replaced as needed. After analysis of a sample containing high concentrations of compounds, a laboratory reagent blank should be analyzed to ensure that accurate values are obtained for the next sample.

5.0 SAFETY

- 5.1 The toxicity or carcinogenicity of chemicals used in this method has not been precisely defined; each chemical should be treated as a potential health hazard, and exposure to these chemicals should be minimized. Each laboratory is responsible for maintaining awareness of OSHA regulations regarding safe handling of chemicals used in this method. Additional references to laboratory safety are cited²⁻⁴.
- 5.2 Some method analytes have been tentatively classified as known or suspected human or mammalian carcinogens. Pure standard materials and stock standard solutions of these compounds should be handled with suitable protection to skin, eyes, etc.

6.0 EQUIPMENT AND SUPPLIES (All specifications are suggested. Catalog numbers are included for illustration only.)

- 6.1 All glassware must be meticulously cleaned. This may be accomplished by washing with detergent and water, rinsing with water, distilled water, or solvents, air-drying, and heating (where appropriate) in a muffle furnace. Volumetric glassware should never be heated to the temperatures obtained in a muffle furnace.
- 6.2 Sample Containers -- 1 L or 1 qt amber glass bottles fitted with Teflon-lined screw caps. Amber bottles are highly recommended since some of the method analytes are very sensitive to light and are oxidized or decomposed upon exposure.
- 6.3 Volumetric Flasks -- Various sizes.
- 6.4 Laboratory or Aspirator Vacuum System -- Sufficient capacity to maintain a minimum vacuum of approximately 13 cm (5 in.) of mercury for cartridges. A greater vacuum (66 cm [26 in.] of mercury) may be used with disks.
- 6.5 Micro Syringes -- Various sizes.

- 6.6 Vials -- Various sizes of amber vials with Teflon-lined screw caps.
- 6.7 Drying Column -- The drying tube should contain about 5-7 g of anhydrous sodium sulfate to prohibit residual water from contaminating the extract. Any small tube may be used, such as a syringe barrel, a glass dropper, etc. as long as no sodium sulfate passes through the column into the extract.
- 6.8 Analytical Balance -- Capable of weighing 0.0001 g accurately.
- 6.9 Fused Silica Capillary Gas Chromatography Column -- Any capillary column that provides adequate resolution, capacity, accuracy, and precision (Section 10.0) can be used. Medium polar, low bleed columns are recommended for use with this method to provide adequate chromatography and minimize column bleed. A 30 m X 0.25 mm id fused silica capillary column coated with a 0.25 μm bonded film of polyphenylmethylsilicone (J&W DB-5.MS) was used to develop this method. Any column which provides analyte separations equivalent to or better than this column may be used.
- 6.10 Gas Chromatograph/Mass Spectrometer/Data System (GC/MS/DS)
- 6.10.1 The GC must be capable of temperature programming and be equipped for splitless/split injection. On-column capillary injection is acceptable if all the quality control specifications in Section 9.0 and Section 10.0 are met. The injection tube liner should be quartz and about 3 mm in diameter. The injection system must not allow the analytes to contact hot stainless steel or other metal surfaces that promote decomposition.
- 6.10.2 The GC/MS interface should allow the capillary column or transfer line exit to be placed within a few mm of the ion source. Other interfaces, for example the open split interface, are acceptable as long as the system has adequate sensitivity (see Section 10.0 for calibration requirements).
- 6.10.3 The mass spectrometer must be capable of electron ionization at a nominal electron energy of 70 eV to produce positive ions. The spectrometer must be capable of scanning at a minimum from 45-450 amu with a complete scan cycle time (including scan overhead) of 1.0 second or less. (Scan cycle time = total MS data acquisition time in seconds divided by number of scans in the chromatogram). The spectrometer must produce a mass spectrum that meets all criteria in Table 1 when an injection of approximately 5 ng of DFTPP is introduced into the GC. An average spectrum across the DFTPP GC peak may be used to test instrument performance. The scan time should be set so that all analytes have a minimum of five scans across the chromatographic peak.

- 6.10.4 An interfaced data system is required to acquire, store, reduce, and output mass spectral data. The computer software must have the capability of processing stored GC/MS data by recognizing a GC peak within any given retention time window, comparing the mass spectrum from the GC peak with spectral data in a user-created data base, and generating a list of tentatively identified compounds with their retention times and scan numbers. The software must also allow integration of the ion abundance of any specific ion between specified time or scan number limits, calculation of response factors as defined in Section 10.2.6 (or construction of a linear regression calibration curve), calculation of response factor statistics (mean and standard deviation), and calculation of concentrations of analytes using either the calibration curve or the equation in Section 12.0.
- 6.11 Standard Filter Apparatus, All Glass or Teflon Lined -- These should be used to carry out disk extractions when no automatic system or manifold is utilized.
- 6.12 A manifold system or an automatic or robotic commercially available sample preparation system designed for either cartridges or disks may be utilized in this method if all quality control requirements discussed in Section 9.0 are met.

7.0 REAGENTS AND STANDARDS

- 7.1 Helium Carrier Gas -- As contaminant free as possible.
- 7.2 Liquid-Solid Extraction (LSE) Cartridges -- Cartridges are inert non-leaching plastic, for example polypropylene, or glass, and must not contain plasticizers, such as phthalate esters or adipates, that leach into the ethyl acetate and methylene chloride eluant. The cartridges are packed with about 1 g of silica, or other inert inorganic support, whose surface is modified by chemically bonded octadecyl (C₁₈) groups. The packing must have a narrow size distribution and must not leach organic compounds into the eluting solvent. One liter of water should pass through the cartridge in about two hours with the assistance of a slight vacuum of about 13 cm (5 in.) of mercury. Section 9.0 provides criteria for acceptable LSE cartridges which are available from several commercial suppliers.

The extraction disks contain octadecyl bonded silica uniformly enmeshed in an inert matrix. The disks used to generate the data in this method were 47 mm in diameter and 0.5 mm in thickness. Other disk sizes are acceptable and larger disks may be used for special problems or when sample compositing is carried out. As with cartridges, the disks should not contain any organic compounds, either from the matrix or the bonded silica, which will leach into the ethyl acetate and methylene chloride eluant. One L of reagent water should pass

through the disks in five to 20 minutes using a vacuum of about 66 cm (26 in.) of mercury. Section 9.0 provides criteria for acceptable LSE disks which are available commercially.

7.3 Solvents

7.3.1 Methylene Chloride, Ethyl Acetate, Acetone, Toluene, and Methanol -- High purity pesticide quality or equivalent.

7.3.2 Reagent Water -- Water in which an interference is not observed at the method detection limit of the compound of interest. Prepare reagent water by passing tap water through a filter bed containing about 0.5 kg of activated carbon or by using a water purification system. Store in clean, narrow-mouth bottles with Teflon-lined septa and screw caps.

7.4 Hydrochloric Acid -- 6N.

7.5 Sodium Sulfate, Anhydrous -- (Soxhlet extracted with methylene chloride for a minimum of four hours or heated to 400°C for two hours in a muffle furnace.)

7.6 Stock Standard Solutions (SSS) -- Individual solutions of surrogates, internal standards, and analytes, or mixtures of analytes, may be purchased from commercial suppliers or prepared from pure materials. To prepare, add 10 mg (weighed on an analytical balance to 0.1 mg) of the pure material to 1.9 mL of methanol, ethyl acetate, or acetone in a 2 mL volumetric flask, dilute to the mark, and transfer the solution to an amber glass vial. If the analytical standard is available only in quantities smaller than 10 mg, reduce the volume of solvent accordingly. Some polycyclic aromatic hydrocarbons are not soluble in methanol, ethyl acetate, or acetone, and their stock standard solutions are prepared in toluene. Methylene chloride should be avoided as a solvent for standards because its high vapor pressure leads to rapid evaporation and concentration changes. Methanol, ethyl acetate, and acetone are not as volatile as methylene chloride, but their solutions must also be handled with care to avoid evaporation. If compound purity is confirmed by the supplier at >96%, the weighed amount can be used without correction to calculate the concentration of the solution (5 µg/µL). Store the amber vials at 4°C or less.

7.7 Primary Dilution Standard Solution (PDS) -- The stock standard solutions are used to prepare a primary dilution standard solution that contains multiple analytes. Mixtures of these analytes to be used as primary dilution standards may be purchased from commercial suppliers. Do not put every method analyte in a single primary dilution standard because chromatographic separation will be extremely difficult, if not impossible. Two or three primary dilution standards would be more appropriate. The recommended solvent for these standards is

acetone or ethyl acetate. Aliquots of each of the stock standard solutions are combined to produce the primary dilution in which the concentration of the analytes is at least equal to the concentration of the most concentrated calibration solution, that is, 10 ng/μL. Store the primary dilution standard solution in an amber vial at 4 °C or less, and check frequently for signs of degradation or evaporation, especially just before preparing calibration solutions.

- 7.8 Fortification Solution of Internal Standards and Surrogates -- Prepare an internal standard solution of acenaphthene-D₁₀, phenanthrene-D₁₀, and chrysene-D₁₂, in methanol, ethyl acetate, or acetone at a concentration of 500 μg/mL of each. This solution is used in the preparation of the calibration solutions. Dilute a portion of this solution by 10 to a concentration of 50 μg/mL and use this solution to fortify the actual water samples (see Section 11.1.3 and Section 11.2.3). Similarly, prepare both surrogate compound solutions (500 μg/mL for calibration, 50 μg/mL for fortification). Surrogate compounds used in developing this method are 1,3-dimethyl-2-nitrobenzene, perylene-D₁₂, and triphenylphosphate. Other surrogates, for example pyrene-D₁₀ may be used in this solution as needed (a 100 μL aliquot of this 50 μg/mL solution added to 1 L of water gives a concentration of 5 μg/L of each internal standard or surrogate). Store these solutions in an amber vial at 4 °C or less. These two solutions may be combined or made as a single solution.
- 7.9 GC/MS Performance Check Solution -- Prepare a solution in methylene chloride of the following compounds at 5 ng/μL of each: DFTPP and endrin, and 4,4'-DDT. Store this solution in an amber vial at 4 °C or less. DFTPP is less stable in acetone or ethyl acetate than it is in methylene chloride.
- 7.10 Calibration Solutions (CAL1 through CAL6) -- Prepare a series of six concentration calibration solutions in ethyl acetate which contain analytes of interest (except pentachlorophenol, toxaphene, and the Aroclor compounds) at suggested concentrations of 10, 5, 2, 1, 0.5, and 0.1 ng/μL, with a constant concentration of 5 ng/μL of each internal standard and surrogate in each CAL solution. It should be noted that CAL1 through CAL6 are prepared by combining appropriate aliquots of a primary dilution standard solution (Section 7.7) and the fortification solution (500 μg/mL) of internal standards and surrogates (Section 7.8). All calibration solutions should contain at least 80% ethyl acetate to avoid gas chromatographic problems. IF ALL METHOD ANALYTES ARE TO BE DETERMINED, TWO OR THREE SETS OF CALIBRATION SOLUTIONS WILL LIKELY BE REQUIRED. Pentachlorophenol is included in this solution at a concentration four times the other analytes. Toxaphene CAL solutions should be prepared as separate solutions at concentrations of 250, 200, 100, 50, 25, and 10 ng/μL. Aroclor CAL solutions should be prepared individually at concentrations of 25, 10, 5, 2.5, 1.0, 0.5, and 0.2 ng/μL. Store these solutions in amber vials in a dark cool

place. Check these solutions regularly for signs of degradation, for example, the appearance of anthraquinone from the oxidation of anthracene.

- 7.11 Reducing Agent, Sodium Sulfite, Anhydrous -- Sodium thiosulfate is not recommended as it may produce a residue of elemental sulfur that can interfere with some analytes.
- 7.12 Fortification Solution for Recovery Standard -- Prepare a solution of terphenyl-D₁₄ at a concentration of 500 µg/mL in methylene chloride or ethyl acetate. These solutions are also commercially available. An aliquot of this solution should be added to each extract to check on the recovery of the internal standards in the extraction process.

8.0 SAMPLE COLLECTION, PRESERVATION, AND STORAGE

- 8.1 Sample Collection -- When sampling from a water tap, open the tap and allow the system to flush until the water temperature has stabilized (usually about two minutes). Adjust the flow to about 500 mL/min. and collect samples from the flowing stream. Keep samples sealed from collection time until analysis. When sampling from an open body of water, fill the sample container with water from a representative area. Sampling equipment, including automatic samplers, must be free of plastic tubing, gaskets, and other parts that may leach interfering analytes into the water sample. Automatic samplers that composite samples over time should use refrigerated glass sample containers if possible.
- 8.2 Sample Dechlorination and Preservation -- All samples should be iced or refrigerated at 4°C and kept in the dark from the time of collection until extraction. Residual chlorine should be reduced at the sampling site by addition of 40-50 mg of sodium sulfite (this may be added as a solid with stirring or shaking until dissolved) to each water sample. It is very important that the sample be dechlorinated prior to adding acid to lower the pH of the sample. Adding sodium sulfite and HCl to the sample bottles prior to shipping to the sampling site is not permitted. Hydrochloric acid should be used at the sampling site to retard the microbiological degradation of some analytes in water. The sample pH is adjusted to < 2 with 6 N hydrochloric acid. This is the same pH used in the extraction, and is required to support the recovery of acidic compounds like pentachlorophenol.
 - 8.2.1 If cyanazine is to be determined, a separate sample must be collected. Cyanazine degrades in the sample when it is stored under acidic conditions or when sodium sulfite is present in the stored sample. Samples collected for cyanazine determination MUST NOT be dechlorinated or acidified when collected. They should be iced or refrigerated as described above and analyzed within 14 days. However,

these samples MUST be dechlorinated and acidified immediately prior to fortification with internal standards and surrogates, and extraction using the same quantities of acid and sodium sulfite described above.

8.2.2 Atraton and prometon are not efficiently extracted from water at pH 2 due to what appears to be their ionization in solution under acidic conditions. In order to determine these analytes accurately, a separate sample must be collected and dechlorinated with sodium sulfite, but no acid should be added. At neutral pH, these two compounds are recovered from water with efficiencies greater than 90%. The data in Tables 3, 4, 5, 6, and 8 are from samples extracted at pH 2.

8.3 Holding Time -- Results of the time/storage study of all method analytes showed that all but six compounds are stable for 14 days in water samples when the samples are dechlorinated, preserved, and stored as described in Section 8.2. Therefore, samples must be extracted within 14 days. If the following analytes are to be determined, the samples cannot be held for 14 days but must be extracted immediately after collection and preservation: carboxin, diazinon, disulfoton, disulfoton sulfoxide, fenamiphos, and terbufos. Sample extracts may be stored at 4 °C for up to 30 days after sample extraction.

8.4 Field Blanks

8.4.1 Processing of a field reagent blank (FRB) is recommended along with each sample set, which is composed of the samples collected from the same general sample site at approximately the same time. At the laboratory, fill a sample container with reagent water, seal, and ship to the sampling site along with the empty sample containers. Return the FRB to the laboratory with the filled sample bottles.

8.4.2 When sodium sulfite and hydrochloric acid are added to samples, use the same procedure to add the same amounts to the FRB.

9.0 **QUALITY CONTROL**

9.1 Quality control (QC) requirements are the initial demonstration of laboratory capability followed by regular analyses of laboratory reagent blanks, laboratory fortified blanks, and laboratory fortified matrix samples. A MDL should be determined for each analyte of interest. The laboratory must maintain records to document the quality of the data generated. Additional quality control practices are recommended.

9.2 Initial Demonstration of Low Disk or Cartridge System Background -- Before any samples are analyzed, or any time a new supply of cartridges or disks is

received from a supplier, it must be demonstrated that a laboratory reagent blank (LRB) is reasonably free of contamination that would prevent the determination of any analyte of concern. In this same experiment, it must be demonstrated that the particle size and packing of the LSE cartridges or the preparation of the disks are acceptable. Consistent flow rate with all samples is an indication of acceptable particle size distribution, packing, and proper preparation.

- 9.2.1 A source of potential contamination is the liquid-solid extraction (LSE) cartridge or disk which could contain phthalate esters, silicon compounds, and other contaminants that could prevent the determination of method analytes⁵. Although disks are generally made of an inert matrix, they may still contain phthalate material. Generally, phthalate esters can be leached from the cartridges into ethyl acetate and methylene chloride and produce a variable background in the water sample. If the background contamination is sufficient to prevent accurate and precise measurements, the condition must be corrected before proceeding with the initial demonstration.
 - 9.2.2 Other sources of background contamination are solvents, reagents, and glassware. Background contamination must be reduced to an acceptable level before proceeding with the next section. In general, background from method analytes should be below the method detection limits.
 - 9.2.3 One L of water should pass through a cartridge in about two hours with a partial vacuum of about 13 cm (5 in.) of mercury. Using full aspirator or pump vacuum, approximately five to 20 minutes will normally be required to pass one liter of drinking water through a disk. The extraction time should not vary unreasonably among LSE cartridges or disks.
- 9.3 Initial Demonstration of Laboratory Accuracy and Precision -- Analyze four to seven replicates of a laboratory fortified blank containing each analyte of concern at a suggested concentration in the range of 2-5 µg/L. This concentration should be approximately in the middle of the calibration range, and will be dependent on the sensitivity of the instrumentation used.
 - 9.3.1 Prepare each replicate by adding sodium sulfite and HCl according to Section 8.2, then adding an appropriate aliquot of the primary dilution standard solution, or certified quality control sample, to reagent water. Analyze each replicate according to the procedures described in Section 11.0.

- 9.3.2 Calculate the measured concentration of each analyte in each replicate, the mean concentration of each analyte in all replicates, and mean accuracy (as mean percentage of true value) for each analyte, and the precision (as relative standard deviation, RSD) of the measurements for each analyte.
- 9.3.3 For each analyte and surrogate, the mean accuracy, expressed as a percentage of the true value, should be 70-130% and the RSD should be < 30%. If these criteria are not met, locate the source of the problem, and repeat with freshly prepared LFBs.
- 9.3.4 Analyze seven replicate laboratory fortified blanks which have been fortified with all analytes of interest at approximately 0.5 µg/L. Calculate the MDL of each analyte using the procedure described in Section 13.1.2¹. It is recommended that these analyses be performed over a period of three or four days to produce more realistic method detection limits.
- 9.3.5 Develop and maintain a system of control charts to plot the precision and accuracy of analyte and surrogate measurements as a function of time. Charting of surrogate recoveries is an especially valuable activity since these are present in every sample and the analytical results will form a significant record of data quality.
- 9.4 Monitor the integrated areas of the quantitation ions of the internal standards and surrogates in continuing calibration checks (see Section 10.3). In laboratory fortified blanks or samples, the integrated areas of internal standards and surrogates will not be constant because the volume of the extract will vary (and is difficult to keep constant). But the ratios of the areas should be reasonably constant in laboratory fortified blanks and samples. The addition of 10 µL of the recovery standard, terphenyl-D₁₄ (500 µg/mL), to the extract is recommended to be used to monitor the recovery of the internal standards in laboratory fortified blanks and samples. Internal standard recovery should be in excess of 70%.
- 9.5 With each batch of samples processed as a group within a 12-hour work shift, analyze a laboratory reagent blank to determine the background system contamination. Any time a new batch of LSE cartridges or disks is received, or new supplies of other reagents are used, repeat the demonstration of low background described in Section 9.2.
- 9.6 With each batch of samples processed as a group within a work shift, analyze a single laboratory fortified blank (LFB) containing each analyte of concern at a concentration as determined in Section 9.3. If more than 20 samples are

included in a batch, analyze a LFB for every 20 samples. Use the procedures described in Section 9.3.3 to evaluate the accuracy of the measurements. If acceptable accuracy cannot be achieved, the problem must be located and corrected before additional samples are analyzed. Add the results to the on-going control charts to document data quality.

Note: If the LFB for each batch of samples contains the individual PCB congeners listed in Section 1.0, then a LFB for each Aroclor is not required. At least one LFB containing toxaphene should be extracted for each 24 hour period during which extractions are performed. Toxaphene should be fortified in a separate LFB from other method analytes.

If individual PCB congeners are not part of the LFB, then it is suggested that one multi-component analyte (toxaphene, chlordane or an Aroclor) LFB be analyzed with each sample set. By selecting a different multi-component analyte for this LFB each work shift, LFB data can be obtained for all of these analytes over the course of several days.

- 9.7 Determine that the sample matrix does not contain materials that adversely affect method performance. This is accomplished by analyzing replicates of laboratory fortified matrix samples and ascertaining that the precision, accuracy, and method detection limits of analytes are in the same range as obtained with laboratory fortified blanks. If a variety of different sample matrices are analyzed regularly, for example, drinking water from groundwater and surface water sources, matrix independence should be established for each. Over time, LFM data should be documented for all routine sample sources for the laboratory. A laboratory fortified sample matrix should be analyzed for every 20 samples processed in the same batch. If the recovery data for a LFM does not meet the criteria in Section 9.3.3., and LFBs show the laboratory to be in control, then the samples from that matrix (sample location) are documented as suspect due to matrix effects.
- 9.8 With each set of samples, a FRB should be analyzed. The results of this analysis will help define contamination resulting from field sampling and transportation activities.
- 9.9 At least quarterly, analyze a quality control sample from an external source. If measured analyte concentrations are not of acceptable accuracy (Section 9.3.3), check the entire analytical procedure to locate and correct the problem source.
- 9.10 Numerous other quality control measures are incorporated into other parts of this procedure, and serve to alert the analyst to potential problems.

10.0 CALIBRATION AND STANDARDIZATION

10.1 Demonstration and documentation of acceptable initial calibration is required before any samples are analyzed and is required intermittently throughout sample analysis as dictated by results of continuing calibration checks. After initial calibration is successful, a continuing calibration check is required each day or at the beginning of each period in which analyses are performed not to exceed 12 hours. Additional periodic calibration checks are good laboratory practice. It is recommended that an additional calibration check be performed at the end of each period of continuous instrument operation, so that all field sample analyses are bracketed by a calibration check standard.

10.2 Initial Calibration

10.2.1 Calibrate the mass and abundance scales of the MS with calibration compounds and procedures prescribed by the manufacturer with any modifications necessary to meet the requirements in Section 10.2.2.

10.2.2 Inject into the GC/MS system a 1 μL aliquot of the 5 $\text{ng}/\mu\text{L}$ solution of DFTPP, endrin and 4,4'-DDT. If desired, the endrin and DDT degradation checks may be performed simultaneously with the DFTPP check or in a separate injection. Acquire a mass spectrum that includes data for m/z 45-450. Use GC conditions that produce a narrow (at least five scans per peak) symmetrical peak for each compound (Section 10.2.3.1 and Section 10.2.3.2). If the DFTPP mass spectrum does not meet all criteria in Table 1, the MS must be retuned and adjusted to meet all criteria before proceeding with calibration. A single spectrum or an average spectrum across the GC peak may be used to evaluate the performance of the system. Locate any degradation products of endrin (endrin ketone [EK] and endrin aldehyde [EA]) and 4,4'-DDT (4,4'-DDE and 4,4'-DDD) at their appropriate retention times and quantitation ions (Table 2). Endrin ketone can be located at ≈ 1.1 to 1.2 times the endrin retention time with prominent m/z 67 and 317 ions in the mass spectrum. If degradation of either endrin or DDT exceeds 20%, maintenance is required on the GC injection port and possibly other areas of the system before proceeding with the calibration. Calculate percent breakdown using peak areas based on total ion current (TIC) as follows:

% 4,4'-DDT breakdown =

$$\frac{\sum \text{TIC area of DDT degradation peaks (DDE+DDD)}}{\sum \text{TIC area of total DDT peaks (DDT+DDE+DDD)}} \times 100$$

% endrin breakdown=

$$\frac{\sum \text{TIC area of endrin degradation peaks (EA+EK)}}{\sum \text{TIC area of total endrin peaks (endrin+EA+EK)}} \times 100$$

10.2.3 Inject a 1 μL aliquot of a medium concentration calibration solution, for example 0.5-2 $\mu\text{g/L}$, and acquire and store data from m/z 45-450 with a total cycle time (including scan overhead time) of 1.0 second or less. Cycle time should be adjusted to measure at least five or more spectra during the elution of each GC peak. Calibration standards for toxaphene and Aroclors must be injected individually.

10.2.3.1 The following are suggested multi-ramp temperature program GC conditions. Adjust the helium carrier gas flow rate to about 33 cm/sec. Inject at 45°C and hold in splitless mode for one minute. Heat rapidly to 130°C. At three minutes start the temperature program: 130-180°C at 12°/min.; 180-240°C at 7°/min.; 240-320°C at 12°/min. Start data acquisition at four minutes.

10.2.3.2 Single ramp linear temperature program suggested GC conditions. Adjust the helium carrier gas flow rate to about 33 cm/sec. Inject at 40°C and hold in splitless mode for one minute. Heat rapidly to 160°C. At three minutes start the temperature program: 160-320°C at 6°/min.; hold at 320°C for two minutes. Start data acquisition at three minutes.

10.2.4 Performance Criteria for the Calibration Standards -- Examine the stored GC/MS data with the data system software.

10.2.4.1 GC Performance -- Anthracene and phenanthrene should be separated by baseline. Benz[a]anthracene and chrysene should be separated by a valley whose height is less than 25% of the average peak height of these two compounds. If the valley between benz[a]anthracene and chrysene exceeds 25%, the GC column requires maintenance. See Section 10.3.6.

10.2.4.2 MS Sensitivity -- The GC/MS/DS peak identification software should be able to recognize a GC peak in the appropriate retention time window for each of the compounds in the calibration solution, and make correct

identifications. If fewer than 99% of the compounds are recognized, system maintenance is required. See Section 10.3.6.

10.2.5 If all performance criteria are met, inject a 1 µL aliquot of each of the other CAL solutions using the same GC/MS conditions. Calibration standards of toxaphene and Aroclors must be injected individually.

10.2.5.1 Some GC/MS systems may not be sensitive enough to detect some of the analytes in the two lowest concentration CAL solutions. In this case, the analyst should prepare additional CAL solutions at slightly higher concentrations to obtain at least five calibration points that bracket the expected analyte concentration range.

10.2.6 Calculate a response factor (RF) for each analyte of interest and surrogate for each CAL solution using the internal standard whose retention time is nearest the retention time of the analyte or surrogate. Table 2 contains suggested internal standards for each analyte and surrogate, and quantitation ions for all compounds. This calculation is supported in acceptable GC/MS data system software (Section 6.10.4), and many other software programs. The RF is a unitless number, but units used to express quantities of analyte and internal standard must be equivalent.

Note: To calibrate for multi-component analytes (toxaphene and Aroclors), one of the following methods should be used.

Option 1 - Calculate an average response factor or linear regression equation for each multi-component analyte from the combined area of all its component peaks identified in the calibration standard chromatogram, using two to three of the suggested quantitation ions in Table 2.

Option 2 - Calculate an average response factor or linear regression equation for each multi-component analyte using the combined areas of three to six of the most intense and reproducible peaks in each of the calibration standard chromatograms. Use an appropriate quantitation ion for each peak.

$$\text{RF} = \frac{(A_x) (Q_{is})}{(A_{is}) (Q_x)}$$

where: A_x = integrated abundance of the quantitation ion of the analyte
 A_{is} = integrated abundance of the quantitation ion internal standard
 Q_x = quantity of analyte injected in ng or concentration units
 Q_{is} = quantity of internal standard injected in ng or concentration units.

10.2.6.1 For each analyte and surrogate, calculate the mean RF from the analyses of the six CAL solutions. Calculate the standard deviation (SD) and the relative standard deviation (RSD) from each mean: $RSD = 100 (SD/M)$. If the RSD of any analyte or surrogate mean RF exceeds 30%, either analyze additional aliquots of appropriate CAL solutions to obtain an acceptable RSD of RFs over the entire concentration range, or take action to improve GC/MS performance. See Section 10.3.6.

10.2.7 As an alternative to calculating mean response factors, use the GC/MS data system software or other available software to generate a linear regression calibration by plotting A_x / A_{is} vs. Q_x .

10.3 Continuing Calibration Check -- Verify the MS tune and initial calibration at the beginning of each 12-hour work shift during which analyses are performed using the following procedure.

10.3.1 Inject a 1 μ L aliquot of the 5 ng/ μ L solution of DFTPP, endrin, and 4,4'-DDT. Acquire a mass spectrum for DFTPP that includes data for m/z 45-450. Ensure that all criteria in Section 10.2.2 are met.

10.3.2 Inject a 1 μ L aliquot of a calibration solution and analyze with the same conditions used during the initial calibration. It is recommended that the concentration of calibration solution be varied, so that the calibration can be verified at more than one point.

Note: If the continuing calibration check standard contains the PCB congeners listed in Section 1.0, calibration verification is not required for each Aroclor. Calibration verification of toxaphene should be performed at least once each 24 hour period.

10.3.3 Demonstrate acceptable performance for the criteria shown in Section 10.2.4.

10.3.4 Determine that the absolute areas of the quantitation ions of the internal standards and surrogate(s) have not changed by more than 30% from the

areas measured in the most recent continuing calibration check, or by more than 50% from the areas measured during initial calibration. If these areas have decreased by more than these amounts, adjustments must be made to restore system sensitivity. These adjustments may require cleaning of the MS ion source, or other maintenance as indicated in Section 10.3.6, and recalibration. Control charts are useful aids in documenting system sensitivity changes.

10.3.5 Calculate the RF for each analyte and surrogate from the data measured in the continuing calibration check. The RF for each analyte and surrogate must be within 30% of the mean value measured in the initial calibration. Alternatively, if a linear regression is used, the calculated amount for each analyte must be $\pm 30\%$ of the true value. If these conditions do not exist, remedial action should be taken which may require recalibration. Any field sample extracts that have been analyzed since the last acceptable calibration verification should be reanalyzed after adequate calibration has been restored.

10.3.5.1 Because of the large number of compounds on the analyte list, it is possible for a few analytes of interest to be outside the continuing calibration criteria. If analytes that missed the calibration check are detected in samples, they may be quantified using a single point calibration. The single point standards should be prepared at concentrations that produce responses close ($\pm 20\%$) to those of the unknowns. If the same analyte misses the continuing calibration check on three consecutive work shifts, remedial action **MUST** be taken. If more than 10% of the analytes of interest miss the continuing calibration check on a single day, remedial action **MUST** be taken.

10.3.6 Some Possible Remedial Actions -- Major maintenance such as cleaning an ion source, cleaning quadrupole rods, replacing filament assemblies, etc. require returning to the initial calibration step.

10.3.6.1 Check and adjust GC and/or MS operating conditions; check the MS resolution, and calibrate the mass scale.

10.3.6.2 Clean or replace the splitless injection liner; silanize a new injection liner.

10.3.6.3 Flush the GC column with solvent according to manufacturer's instructions.

- 10.3.6.4 Break off a short portion (about 1 m) of the column from the end near the injector; or replace GC column. This action will cause a change in retention times.
- 10.3.6.5 Prepare fresh CAL solutions, and repeat the initial calibration step.
- 10.3.6.6 Clean the MS ion source and rods (if a quadrupole).
- 10.3.6.7 Replace any components that allow analytes to come into contact with hot metal surfaces.
- 10.3.6.8 Replace the MS electron multiplier, or any other faulty components.

11.0 PROCEDURE

11.1 Cartridge Extraction

- 11.1.1 This procedure may be carried out in the manual mode or in the automated mode (Section 6.12) using a robotic or automatic sample preparation device. If an automatic system is used to prepare samples, follow the manufacturer's operating instructions, but follow this procedure. If the manual mode is used, a suggested setup of the extraction apparatus is shown in Figure 1A. The reservoir is not required, but recommended for convenient operation. Water drains from the reservoir through the LSE cartridge and into a syringe needle which is inserted through a rubber stopper into the suction flask. A slight vacuum of approximately 13 cm (5 in.) of mercury is used during all operations with the apparatus. About two hours should be required to draw a liter of water through the cartridge.
- 11.1.2 Elute each cartridge with a 5 mL aliquot of ethyl acetate followed by a 5 mL aliquot of methylene chloride. Let the cartridge drain dry after each flush. Then elute the cartridge with a 10 mL aliquot of methanol, but DO NOT allow the methanol to elute below the top of the cartridge packing. From this point, do not allow the cartridge to go dry. Add 10 mL of reagent water to the cartridge, but before the reagent water level drops below the top edge of the packing, begin adding sample to the solvent reservoir.
- 11.1.3 Pour the water sample into the 2 L separatory funnel with the stopcock closed, add 5 mL methanol, and mix well. If a vacuum manifold is used instead of the separatory funnel, the sample may be transferred directly

to the cartridge after the methanol is added to the sample. (Residual chlorine should not be present as a reducing agent should have been added at the time of sampling. Also the pH of the sample should be about 2. If residual chlorine is present and/or the pH is >2, the sample may be invalid.) Add a 100 μ L aliquot of the fortification solution (50 μ g/mL) for internal standards and surrogates, and mix immediately until homogeneous. The resulting concentration of these compounds in the water should be 5 μ g/L.

- 11.1.4 Periodically transfer a portion of the sample into the solvent reservoir. The water sample will drain into the cartridge, and from the exit into the suction flask. Maintain the packing material in the cartridge immersed in water at all times. After all of the sample has passed through the LSE cartridge, draw air or nitrogen through the cartridge for 10 minutes.
- 11.1.5 Transfer the 125 mL solvent reservoir and LSE cartridge (from Figure 1A) to the elution apparatus if used (Figure 1B). The same 125 mL solvent reservoir is used for both apparatus. Rinse the inside of the 2 L separatory funnel and the sample jar with 5 mL of ethyl acetate and elute the cartridge with this rinse into the collection tube. Wash the inside of the separatory funnel and the sample jar with 5 mL methylene chloride and elute the cartridge, collecting the rinse in the same collection tube. Small amounts of residual water from the sample container and the LSE cartridge may form an immiscible layer with the eluate. Pass the eluate through the drying column (Section 6.7) which is packed with approximately 5-7 g of anhydrous sodium sulfate and collect in a second vial. Wash the sodium sulfate with at least 2 mL methylene chloride and collect in the same vial. Concentrate the extract in a warm water bath under a gentle stream of nitrogen. Do not concentrate the extract to less than 0.5 mL, as this will result in losses of analytes. Make any volume adjustments with ethyl acetate. It is recommended that an aliquot of the recovery standard be added to the concentrated extract to check the recovery of the internal standards (see Section 7.12).

11.2 Disk Extraction

- 11.2.1 This procedure was developed using the standard 47 mm diameter disks. Larger disks (90 mm diameter) may be used if sample compositing is being done or special matrix problems are encountered. If larger disks are used, the washing solvent volume is 15 mL, the conditioning solvent volume is 15 mL, and the elution solvent volume is two 15 mL aliquots.
 - 11.2.1.1 Extractions using the disks may be carried out either in the manual or automatic mode (Section 6.12) using an

automatic sample preparation device. If an automatic system is used to prepare samples, follow the manufacturer's operating instructions, but follow this procedure. Insert the disk into the filter apparatus (Figure 2) or sample preparation unit. Wash the disk with 5 mL of a 1:1 mixture of ethyl acetate (EtAc) and methylene chloride (MeCl₂) by adding the solvent to the disk, drawing about half through the disk, allowing it to soak the disk for about a minute, then drawing the remaining solvent through the disk.

Note: Soaking the disk may not be desirable when disks other than Teflon are used. Instead, apply a constant, low vacuum in this Section and Section 11.2.1.2 to ensure adequate contact time between solvent and disk.

- 11.2.1.2 Pre-wet the disk with 5 mL methanol (MeOH) by adding the MeOH to the disk and allowing it to soak for about a minute, then drawing most of the remaining MeOH through. A layer of MeOH must be left on the surface of the disk, which should not be allowed to go dry from this point until the end of the sample extraction. THIS IS A CRITICAL STEP FOR A UNIFORM FLOW AND GOOD RECOVERY.
- 11.2.1.3 Rinse the disk with 5 mL reagent water by adding the water to the disk and drawing most through, again leaving a layer on the surface of the disk.
- 11.2.2 Add 5 mL MeOH per liter of water to the sample. Mix well. (Residual chlorine should not be present as a reducing agent should have been added at the time of sampling. Also the pH of the sample should be about 2. If residual chlorine is present and/or the pH is >2, the sample may be invalid.)
- 11.2.3 Add 100 µL of the internal standard and surrogate compound fortification solution (50 µg/mL) to the sample and shake or mix until the sample is homogeneous. The resulting concentration of these compounds in the water should be 5 µg/L.
- 11.2.4 Add the water sample to the reservoir and apply full vacuum to begin the extraction. Particulate-free water may pass through the disk in as little as five minutes without reducing analyte recoveries. Extract the entire sample, draining as much water from the sample container as possible. Dry the disk by maintaining vacuum for about 10 minutes.

11.2.5 Remove the filtration top, but do not disassemble the reservoir and fritted base. If a suction flask is being used, empty the water from the flask, and insert a suitable collection tube to contain the eluant. The only constraint on the sample tube is that it fit around the drip tip of the fritted base. Reassemble the apparatus.

11.2.6 Add 5 mL of ethyl acetate to the sample bottle, and rinse the inside walls thoroughly. Allow the solvent to settle to the bottom of the bottle, then transfer it to the disk. A disposable pipet or syringe may be used to do this, rinsing the sides of the glass filtration reservoir in the process. Draw about half of the solvent through the disk, release the vacuum, and allow the disk to soak for a minute. Draw the remaining solvent through the disk.

Note: Soaking the disk may not be desirable if disks other than Teflon are used. Instead, apply a constant, low vacuum in this Section and Section 11.2.7 to ensure adequate contact time between solvent and disk.

11.2.7 Repeat the above step (Section 11.2.6) with methylene chloride.

11.2.8 Using a syringe or disposable pipet, rinse the filtration reservoir with two 3 mL portions of 1:1 EtAc:MeCl₂. Draw the solvent through the disk and into the collector tube. Pour the combined eluates (Section 11.2.6 through Section 11.2.8) through the drying tube (Section 6.7) containing about 5-7 g of anhydrous sodium sulfate. Rinse the drying tube and sodium sulfate with two 3 mL portions of 1:1 EtAc:MeCl₂ mixture. Collect all the extract and washings in a concentrator tube.

11.2.9 While gently heating the extract in a water bath or a heating block, concentrate to between 0.5 mL and 1 mL under a gentle stream of nitrogen. Do not concentrate the extract to less than 0.5 mL, since this will result in losses of analytes. Make any volume adjustments with ethyl acetate. It is recommended that an aliquot of the recovery standard be added to the concentrated extract to check the recovery of the internal standards (see Section 7.12).

11.3 Analyze a 1 μ L aliquot with the GC/MS system under the same conditions used for the initial and continuing calibrations (Section 10.2.3).

11.4 At the conclusion of data acquisition, use the same software that was used in the calibration procedure to tentatively identify peaks in predetermined retention time windows of interest. Use the data system software to examine the ion abundances of components of the chromatogram.

- 11.5 Identification of Analytes -- Identify a sample component by comparison of its mass spectrum (after background subtraction) to a reference spectrum in the user-created data base. The GC retention time of the sample component should be within five seconds of the retention time observed for that same compound in the most recently analyzed continuing calibration check standard.
- 11.5.1 In general, all ions that are present above 10% relative abundance in the mass spectrum of the standard should be present in the mass spectrum of the sample component and should agree within absolute 20%. For example, if an ion has a relative abundance of 30% in the standard spectrum, its abundance in the sample spectrum should be in the range of 10-50%. Some ions, particularly the molecular ion, are of special importance, and should be evaluated even if they are below 10% relative abundance.
- 11.5.2 Identification is hampered when sample components are not resolved chromatographically and produce mass spectra containing ions contributed by more than one analyte. When GC peaks obviously represent more than one sample component (i.e., broadened peak with shoulder(s) or valley between two or more maxima), appropriate analyte spectra and background spectra can be selected by examining plots of characteristic ions for tentatively identified components. When analytes coelute (i.e., only one GC peak is apparent), the identification criteria can be met but each analyte spectrum will contain extraneous ions contributed by the coeluting compound.
- 11.5.3 Structural isomers that produce very similar mass spectra can be explicitly identified only if they have sufficiently different GC retention times. See Section 10.2.4.1. Acceptable resolution is achieved if the height of the valley between two isomer peaks is less than 25% of the average height of the two peak heights. Otherwise, structural isomers are identified as isomeric pairs. Benzo[b] and benzo[k]fluoranthene may be measured as an isomeric pair. MGK 264 is made up of two structural isomers. These are listed separately in the data tables.
- 11.5.4 Each multi-component analyte can be identified by the presence of its individual components in a characteristic pattern based on the relative amounts of each component present. Chromatograms of standard materials of multi-component analytes should be carefully evaluated, so that these patterns can be recognized by the analyst.

12.0 DATA ANALYSIS AND CALCULATIONS

12.1 Complete chromatographic resolution is not necessary for accurate and precise measurements of analyte concentrations if unique ions with adequate intensities are available for quantitation. In validating this method, concentrations were calculated by measuring the characteristic ions listed in Table 2. If the response of any analyte exceeds the calibration range established in Section 10.0, dilute the extract and reanalyze.

12.1.1 Calculate analyte and surrogate concentrations, using the multipoint calibration established in Section 10.0. Do not use daily calibration verification data to quantitate analytes in samples.

$$C_x = \frac{(A_x) (Q_{is})}{(A_{is}) RF V}$$

where: C_x = concentration of analyte or surrogate in $\mu\text{g/L}$ in the water sample

A_x = integrated abundance of the quantitation ion of the analyte in the sample

A_{is} = integrated abundance of the quantitation ion of the internal standard in the sample

Q_{is} = total quantity (in micrograms) of internal standard added to the water sample

V = original water sample volume in liters

RF = mean response factor of analyte from the initial calibration.

RF is a unitless value

12.1.2 Alternatively, use the GC/MS system software or other available proven software to compute the concentrations of the analytes and surrogates from the linear regression established in Section 10.0. Do not use daily calibration verification data to quantitate analytes in samples.

12.1.3 Calculations should utilize all available digits of precision, but final reported concentrations should be rounded to an appropriate number of significant figures (one digit of uncertainty). Experience indicates that three significant figures may be used for concentrations above 99 $\mu\text{g/L}$, two significant figures for concentrations between 1-99 $\mu\text{g/L}$, and one significant figure for lower concentrations.

12.2 To quantitate multi-component analytes (toxaphene and Aroclors), one of the following methods should be used.

Option 1 - Calculate an average RF or linear regression equation for each multi-component analyte from the combined area of all its component peaks identified in the calibration standard chromatogram, using two to three of the suggested quantitation ions in Table 2.

Option 2 - Calculate an average response factor or linear regression equation for each multi-component analyte using the combined areas of three to six of the most intense and reproducible peaks in each of the calibration standard chromatograms.

When quantifying multi-component analytes in samples, the analyst should use caution to include only those peaks from the sample that are attributable to the multi-component analyte. Option 1 should not be used if there are significant interference peaks within the Aroclor or toxaphene pattern. Option 2 was used to generate the data in Table 6.

13.0 METHOD PERFORMANCE

13.1 Single laboratory accuracy and precision data (Tables 3-6) for each listed analyte (except multi-component analytes) were obtained at a concentration of 0.5 µg/L and/or 5 µg/L in reagent water utilizing both the disk and the cartridge technology and two different GC/MS systems, an ion trap and a quadrupole mass spectrometer. Table 8 lists accuracy and precision data from replicate determinations of method analytes in tap water using liquid-solid cartridge extractions and the ion trap mass spectrometer. Any type of GC/MS system may be used to perform this method if it meets the requirement in Sect. 6.10 and the quality control criteria in Section 9.0. The multi-component analytes (i.e., toxaphene and Aroclors) are presented in Tables 5 and 6. The average recoveries in the tables represent six to eight replicate analyses done over a minimum of a two-day period.

13.1.2 With these data, the method detection limits (MDL) in the tables were calculated using the formula:

$$\text{MDL} = S t_{(n-1, 1-\alpha = 0.99)}$$

where: $t_{(n-1, 1-\alpha = 0.99)}$ = Student's t value for the 99% confidence level
with n-1 degrees of freedom

n = number of replicates

S = standard deviation of replicate analyses

13.2 Problem Compounds

- 13.2.1 Some polycyclic aromatic hydrocarbons (PAH), including the labeled PAHs used in this method as internal standards, are rapidly oxidized and/or chlorinated in water containing residual chlorine. Therefore, residual chlorine must be reduced at the time of sampling. These same types of compounds, especially anthracene, benz[a]anthracene, and benzo[a]pyrene, are susceptible to photodegradation. Therefore, care should be taken to avoid exposing standards, samples, and extracts to direct light. Low recoveries of some PAH compounds have been observed when the cartridge or disk was air dried longer than 10 minutes (Section 11.1.4 and Section 11.2.4). Drying times longer than 10 minutes should be avoided, or nitrogen may be used to dry the cartridge or disk to minimize the possible oxidation of these analytes during the drying step.
- 13.2.2 Merphos is partially converted to DEF in aqueous matrices, and also when introduced into a hot gas chromatographic injection system. The efficiency of this conversion appears to be unpredictable and not reproducible. Therefore, merphos cannot be quantified and can only be identified by the presence of DEF in the sample.
- 13.2.3 Several of the nitrogen and/or phosphorus containing pesticides listed as method analytes are difficult to chromatograph and appear as broad, asymmetrical peaks. These analytes, whose peak shapes are typically poor, are listed in Table 7. The method performance for these analytes is strongly dependent on chromatographic efficiency and performance. Poor peak shapes will affect the linearity of the calibration curves and result in poor accuracy at low concentrations. Also listed in Table 7 are data generated at a mid-concentration level for these analytes. In most cases, the data at this concentration meet the quality control criteria requirements of the method.
- 13.2.4 Phthalate esters and other background components appear in variable quantities in laboratory and field reagent blanks, and generally cannot be accurately measured at levels below about 2 µg/L. Subtraction of the concentration in the blank from the concentration in the sample at or below the 2 µg/L level is not recommended because the concentration of the background in the blank is highly variable.
- 13.2.5 Atraton and prometon are not efficiently extracted from the water at pH 2 due to what appears to be their ionization occurring in solution under acidic conditions. In order to determine these analytes accurately, a separate sample must be collected and dechlorinated with sodium sulfite, but no HCl should be added at the time of collection. At neutral pH, these two compounds are recovered from water with efficiencies greater

than 90%. The data in Tables 3, 4, 5, 6, and 8 are from samples extracted at pH 2.

13.2.6 Carboxin, disulfoton, and disulfoton sulfoxide were found to be unstable in water and began to degrade almost immediately. These analytes may be identified by this method but not accurately measured.

13.2.7 Low recoveries of metribuzin were observed in samples fortified with relatively high concentrations of additional method analytes. In samples fortified with approximately 80 analytes at 5 µg/L each, metribuzin was recovered at about 50% efficiency. This suggests that metribuzin may break through the C-18 phase in highly contaminated samples resulting in low recoveries.

13.2.8 If cyanazine is to be determined, a separate sample must be collected. Cyanazine degrades in the sample when it is stored under acidic conditions or when sodium sulfite is present in the stored sample. Samples collected for cyanazine determination MUST NOT be dechlorinated or acidified when collected. They should be iced or refrigerated and analyzed within 14 days. However, these samples MUST be dechlorinated and acidified immediately prior to fortification with internal standards and surrogates, and extraction using the same quantities of acid and sodium sulfite described in Section 8.0.

14.0 POLLUTION PREVENTION

14.1 This method utilizes liquid-solid extraction (LSE) technology to remove the analytes from water. It requires the use of very small volumes of organic solvent and very small quantities of pure analytes, thereby eliminating the potential hazards to both the analyst and the environment involved with the use of large volumes of organic solvents in conventional liquid-liquid extractions.

14.2 For information about pollution prevention that may be applicable to laboratory operations, consult "Less Is Better: Laboratory Chemical Management for Waste Reduction" available from the American Chemical Society's Department of Government Relations and Science Policy, 1155 16th Street N.W., Washington, D.C. 20036.

15.0 WASTE MANAGEMENT

15.1 It is the laboratory's responsibility to comply with all federal, state, and local regulations governing waste management, particularly the hazardous waste identification rules and land disposal restrictions. The laboratory using this method has the responsibility to protect the air, water, and land by minimizing and controlling all releases from fume hoods and bench operations. Compliance

is also required with any sewage discharge permits and regulations. For further information on waste management, see "The Waste Management Manual for Laboratory Personnel", also available from the American Chemical Society at the address in Section 14.2.

16.0 REFERENCES

1. Glaser, J. A., D. L. Foerst, G. D. McKee, S. A. Quave, and W. L. Budde. "Trace Analyses for Wastewaters", Environ. Sci. Technol. 1981 15, 1426-1435. or 40 CFR, Part 136, Appendix B.
2. "Carcinogens - Working With Carcinogens", Department of Health, Education, and Welfare, Public Health Service, Center for Disease Control, National Institute for Occupational Safety and Health, Publication No. 77-206, August 1977.
3. "OSHA Safety and Health Standards, General Industry", (29CFR1910), Occupational Safety and Health Administration, OSHA 2206, (Revised, January 1976).
4. "Safety in Academic Chemistry Laboratories", American Chemical Society Publication, Committee on Chemical Safety, 3rd Edition, 1979.
5. Junk, G. A., M. J. Avery, J. J. Richard. "Interferences in Solid-Phase Extraction Using C-18 Bonded Porous Silica Cartridges", Anal. Chem. 1988, 60, 1347.

17.0 TABLES, DIAGRAMS, FLOWCHARTS, AND VALIDATION DATA

TABLE 1. ION ABUNDANCE CRITERIA FOR BIS(PERFLUOROPHENYL)PHENYL PHOSPHINE (DECAFLUOROTRIPHENYLPHOSPHINE, DFTPP)

Mass (M/z)	Relative Abundance Criteria	Purpose of Checkpoint¹
51	10-80% of the base peak	Low-mass sensitivity
68	< 2% of Mass 69	Low-mass resolution
70	< 2% of Mass 69	Low-mass resolution
127	10-80% of the base peak	Low- to mid-mass sensitivity
197	< 2% of Mass 198	Mid-mass resolution
198	Base peak or > 50% of Mass 442	Mid-mass resolution and sensitivity
199	5-9% of Mass 198	Mid-mass resolution and isotope ratio
275	10-60% of the base peak	Mid- to high-mass sensitivity
365	> 1% of the base peak	Baseline threshold
441	Present and < Mass 443	High-mass resolution
442	Base peak or > 50% of Mass 198	High-mass resolution and sensitivity
443	15-24% of Mass 442	High-mass resolution and isotope ratio

¹All ions are used primarily to check the mass measuring accuracy of the mass spectrometer and data system, and this is the most important part of the performance test. The three resolution checks, which include natural abundance isotope ratios, constitute the next most important part of the performance test. The correct setting of the baseline threshold, as indicated by the presence of low intensity ions, is the next most important part of the performance test. Finally, the ion abundance ranges are designed to encourage some standardization to fragmentation patterns.

TABLE 2. RETENTION TIME DATA, QUANTITATION IONS, AND INTERNAL STANDARD REFERENCES FOR METHOD ANALYTES

Compound	Retention Time (min:sec)		Quantitation Ion	IS Reference #
	A ^a	B ^b		
<u>Internal Standards</u>				
Acenaphthene-d10 (#1)	7:47	7:01	164	
Chrysene-d12 (#2)	21:33	18:09	240	
Phenanthrene-d10 (#3)	11:37	10:13	188	
<u>Surrogates</u>				
1,3-Dimethyl-2-Nitrobenzene	5:16	4:33	134	1
Perylene-d12	26:60	21:31	264	3
Triphenylphosphate	20:25	17:25	326/325	3
<u>Target Analytes</u>				
Acenaphthylene	7:30	6:46	152	1
Alachlor	12:59	11:24	160	2
Aldrin	14:24	12:31	66	2
Ametryn	13:11	11:35	227/170	2
Anthracene	11:50	10:24	178	2
Aroclor 1016		7:30-14:00	152/256/292	2
Aroclor 1221		6:38-11:25	152/222/256	2
Aroclor 1232		6:38-13:54	152/256/292	2
Aroclor 1242		6:38-15:00	152/256/292	2
Aroclor 1248		8:47-15:00	152/256/292	2
Aroclor 1254		11:00- 18:00	220/326/360	2
Aroclor 1260		13:10- 21:00	326/360/394	2
Atraton	10:31	9:25	196/169	1
Atrazine	10:49	9:38	200/215	1/2
Benz[a]anthracene	21:31	18:08	228	3
Benzo[b]fluoranthene	25:33	20:44	252	3
Benzo[k]fluoranthene	25:45	20:48	252	3
Benzo[g,h,i]perylene	31:16	24:18	276	3
Benzo[a]pyrene	25:24	21:25	252	3
Bromacil	13:46	12:03	205	2
Butachlor	16:25	14:16	176/160	2
Butylate	6:60	6:23	57/146	1
Butylbenzylphthalate	19:39	16:53	149	2/3
Carboxin	17:37	15:13	143	2
Chlordane, (alpha-Chlordane)	16:43	14:28	375/373	2/3

TABLE 2. RETENTION TIME DATA, QUANTITATION IONS, AND INTERNAL STANDARD REFERENCES FOR METHOD ANALYTES

Compound	Retention		Quantitation Ion	IS Reference #
	A ^a	B ^b		
Chlordane, (gamma-Chlordane)	16:19	14:05	373	2/3
Chlordane, (trans-Nonachlor)	16:47	14:30	409	2/3
Chlorneb	7:47	7:05	191	1
Chlorobenzilate	18:22	15:52	139	2
2-Chlorobiphenyl	7:53	7:08	188	1
Chlorpropham	9:33	8:36	127	1
Chlorpyrifos	14:10	12:23	197/97	2
Chlorothalonil	11:38	10:15	266	2
Chrysene	21:39	18:13	228	3
Cyanazine	14:14	12:28	225/68	2
Cycloate	9:23	8:26	83/154	1
DCPA	14:20	12:30	301	2
4,4'-DDD	18:40	16:05	235/165	2
4,4'-DDE	17:20	14:59	246	2
4,4'-DDT	19:52	17:00	235/165	2
DEF	17:24	15:05	57/169	2
Diazinon	11:19	10:05	137/179	2
Dibenz[a,h]anthracene	30:32	23:47	278	3
Di-n-Butylphthalate	13:49	12:07	149	2
2,3-Dichlorobiphenyl	10:20	9:12	222/152	1
Dichlorvos	5:31	4:52	109	1
Dieldrin	17:35	15:09	79	2
Di(2-Ethylhexyl)adipate	20:11	17:19	129	2/3
Di(2-Ethylhexyl)phthalate	22:11	18:39	149	2/3
Diethylphthalate	8:68	7:53	149	1
Dimethylphthalate	7:13	6:34	163	1
2,4-Dinitrotoluene	8:08	7:22	165	1
2,6-Dinitrotoluene	7:19	6:40	165	1
Diphenamid	14:52	12:58	72/167	2
Disulfoton	11:43	10:22	88	2
Disulfoton Sulfone	16:28	14:17	213/153	2
Disulfoton Sulfoxide	6:09	5:31	97	1
Endosulfan I	16:44	14:26	195	2
Endosulfan II	18:35	15:59	195	2
Endosulfan Sulfate	19:47	16:54	272	2
Endrin	18:15	15:42	67/81	2
Endrin Aldehyde	19:02	16:20	67	2
EPTC	6:23	5:46	128	1
Ethoprop	9:19	8:23	158	1

TABLE 2. RETENTION TIME DATA, QUANTITATION IONS, AND INTERNAL STANDARD REFERENCES FOR METHOD ANALYTES

Compound	Retention		Quantitation Ion	IS Reference #
	A ^a	B ^b		
Etridiazole	7:14	6:37	211/183	1
Fenamiphos	16:48	14:34	303/154	2
Fenarimol	23:26	19:24	139	3
Fluorene	8:59	8:03	166	1
Fluridone	26:51	21:26	328	3
HCH, alpha	10:19	9:10	181	1
HCH, beta	10:57	9:41	181	2
HCH, delta	11:57	10:32	181	2
HCH, gamma (Lindane)	11:13	9:54	181	2
Heptachlor	13:19	11:37	100	2
Heptachlor epoxide	15:34	13:29	81	2
2,2',3,3',4,4',6-Heptachlorobiphenyl	21:23	18:04	394/396	3
Hexachlorobenzene	10:27	9:15	284	1
2,2',4,4',5,6'-Hexachlorobiphenyl	17:32	15:09	360	2
Hexachlorocyclopentadiene	5:16	5:38	237	1
Hexazinone	20:00	17:06	171	2
Indeno[1,2,3-cd]pyrene	30:26	23:43	276	3
Isophorone	4:54	4:10	82	1
Merphos	15:38	13:35	209/153	2
Methoxychlor	21:36	18:14	227	3
Methyl Paraoxon	11:57	10:22	109	2
Metolachlor	14:07	12:20	162	2
Metribuzin	12:46	11:13	198	2
Mevinphos	5:54	6:19	127	1
MGK 264 - Isomer a	15:18	13:00	164/66	2
MGK 264 - Isomer b	14:55	13:19	164	2
Molinate	8:19	7:30	126	1
Napropamide	16:53	14:37	72	2
Norflurazon	19:31	16:46	145	2
2,2',3,3',4,5',6,6'-Octachlorobiphenyl	21:33	18:11	430/428	3
Pebulate	7:18	6:40	128	1
2,2',3',4,6-Pentachlorobiphenyl	15:37	13:33	326	2
Pentachlorophenol	11:01	9:45	266	2
Permethrin, cis	24:25	20:01	183	3
Permethrin, trans	24:39	20:10	183	3
Phenanthrene	11:41	10:16	178	2
Prometon	10:39	9:32	225/168	2

TABLE 2. RETENTION TIME DATA, QUANTITATION IONS, AND INTERNAL STANDARD REFERENCES FOR METHOD ANALYTES

Compound	Retention		Quantitation Ion	IS Reference #
	Time (min:sec) A^a	B^b		
Prometryn	13:15	11:39	241/184	2
Pronamide	11:19	10:02	173	2
Propachlor	9:00	8:07	120	1
Propazine	10:54	9:43	214/172	2
Pyrene	16:41	14:24	202	2
Simazine	10:41	9:33	201/186	2
Simetryn	13:04	11:29	213	2
Stirofos	16:20	14:11	109	2
Tebuthiuron	8:00	7:16	156	1
Terbacil	11:44	10:24	161	2
Terbufos	11:14	9:58	57	2
Terbutryn	13:39	11:58	226/185	2
2,2',4,4'-Tetrachlorobiphenyl	14:02	12:14	292	2
Toxaphene		13:00- 21:00	159	2
Triademefon	14:30	12:40	57	2
2,4,5-Trichlorobiphenyl	12:44	10:53	256	2
Tricyclazole	17:15	14:51	189	2
Trifluralin	9:31	8:37	306	1
Vernolate	7:10	6:32	128	1

^aSingle-ramp linear temperature program conditions (Section 10.2.3.2).

^bMulti-ramp linear temperature program conditions (Section 10.2.3.1).

TABLE 3. ACCURACY AND PRECISION DATA FROM EIGHT DETERMINATIONS OF THE METHOD ANALYTES IN REAGENT WATER USING LIQUID-SOLID C-18 CARTRIDGE EXTRACTION AND THE QUADRUPOLE MASS SPECTROMETER

Compound	True Conc. (µg/L)	Mean Observed Conc. (µg/L)	Relative Standard Deviation (%)	Mean Method Accuracy (% of True Conc.)	MDL (µg/L)
<u>Surrogates</u>					
1,3-Dimethyl-2-Nitrobenzene	5.0	4.7	3.9	94	
Perylene-d12	5.0	4.9	4.8	98	
Triphenylphosphate	5.0	5.5	6.3	110	
<u>Target Analytes</u>					
Acenaphthylene	0.50	0.45	8.2	91	0.11
Alachlor	0.50	0.47	12	93	0.16
Aldrin	0.50	0.40	9.3	80	0.11
Ametryn	0.50	0.44	6.9	88	0.092
Anthracene	0.50	0.53	4.3	106	0.068
Aroclor 1016	ND	ND	ND	ND	ND
Aroclor 1221	ND	ND	ND	ND	ND
Aroclor 1232	ND	ND	ND	ND	ND
Aroclor 1242	ND	ND	ND	ND	ND
Aroclor 1448	ND	ND	ND	ND	ND
Aroclor 1254	ND	ND	ND	ND	ND
Aroclor 1260	ND	ND	ND	ND	ND
Atraton ^a	0.50	0.35	15	70	0.16
Atrazine	0.50	0.54	4.8	109	0.078
Benz[a]anthracene	0.50	0.41	16	82	0.20
Benzo[b]fluoranthene	0.50	0.49	20	98	0.30
Benzo[k]fluoranthene	0.50	0.51	35	102	0.54
Benzo[g,h,i]perylene	0.50	0.72	2.2	144	0.047
Benzo[a]pyrene	0.50	0.58	1.9	116	0.032
Bromacil	0.50	0.54	6.4	108	0.10
Butachlor	0.50	0.62	4.1	124	0.076
Butylate	0.50	0.52	4.1	105	0.064
Butylbenzylphthalate	0.50	0.77	11	154	0.25
Carboxin	5.0	3.8	12	76	1.4
Chlordane (alpha-Chlordane)	0.50	0.36	11	72	0.12
Chlordane (gamma-Chlordane)	0.50	0.40	8.8	80	0.11
Chlordane (trans-Nonachlor)	0.50	0.43	17	87	0.22

TABLE 3. ACCURACY AND PRECISION DATA FROM EIGHT DETERMINATIONS OF THE METHOD ANALYTES IN REAGENT WATER USING LIQUID-SOLID C-18 CARTRIDGE EXTRACTION AND THE QUADRUPOLE MASS SPECTROMETER

Compound	True Conc. (µg/L)	Mean Observed Conc. (µg/L)	Relative Standard Deviation (%)	Mean Method Accuracy (% of True Conc.)	MDL (µg/L)
Chlorneb	0.50	0.51	5.7	102	0.088
Chlorobenzilate	5.0	6.5	6.9	130	1.3
2-Chlorobiphenyl	0.50	0.40	7.2	80	0.086
Chlorpropham	0.50	0.61	6.2	121	0.11
Chlorpyrifos	0.50	0.55	2.7	110	0.044
Chlorothalonil	0.50	0.57	6.9	113	0.12
Chrysene	0.50	0.39	7.0	78	0.082
Cyanazine	0.50	0.71	8.0	141	0.17
Cycloate	0.50	0.52	6.1	104	0.095
DCPA	0.50	0.55	5.8	109	0.094
4,4'-DDD	0.50	0.54	4.4	107	0.071
4,4'-DDE	0.50	0.40	6.3	80	0.075
4,4'-DDT	0.50	0.79	3.5	159	0.083
Diazinon	0.50	0.41	8.8	83	0.11
Dibenz[a,h]anthracene	0.50	0.53	0.5	106	0.010
Di-n-butylphthalate	ND	ND	ND	ND	ND
2,3-Dichlorobiphenyl	0.50	0.40	11	80	0.14
Dichlorvos	0.50	0.55	9.1	110	0.15
Dieldrin	0.50	0.48	3.7	96	0.053
Di(2-ethylhexyl)adipate	0.50	0.42	7.1	84	0.090
Di(2-ethylhexyl)phthalate	ND	ND	ND	ND	ND
Diethylphthalate	0.50	0.59	9.6	118	0.17
Dimethylphthalate	0.50	0.60	3.2	120	0.058
2,4-Dinitrotoluene	0.50	0.60	5.6	119	0.099
2,6-Dinitrotoluene	0.50	0.60	8.8	121	0.16
Diphenamid	0.50	0.54	2.5	107	0.041
Disulfoton	5.0	3.99	5.1	80	0.62
Disulfoton Sulfone	0.50	0.74	3.2	148	0.070
Disulfoton Sulfoxide	0.50	0.58	12	116	0.20
Endosulfan I	0.50	0.55	18	110	0.30
Endosulfan II	0.50	0.50	29	99	0.44
Endosulfan Sulfate	0.50	0.62	7.2	124	0.13
Endrin	0.50	0.54	18	108	0.29
Endrin Aldehyde	0.50	0.43	15	87	0.19

TABLE 3. ACCURACY AND PRECISION DATA FROM EIGHT DETERMINATIONS OF THE METHOD ANALYTES IN REAGENT WATER USING LIQUID-SOLID C-18 CARTRIDGE EXTRACTION AND THE QUADRUPOLE MASS SPECTROMETER

Compound	True Conc. (µg/L)	Mean Observed Conc. (µg/L)	Relative Standard Deviation (%)	Mean Method Accuracy (% of True Conc.)	MDL (µg/L)
EPTC	0.50	0.50	7.2	100	0.11
Ethoprop	0.50	0.62	6.1	123	0.11
Etridiazole	0.50	0.69	7.6	139	0.16
Fenamiphos	5.0	5.2	6.1	103	0.95
Fenarimol	5.0	6.3	6.5	126	1.2
Fluorene	0.50	0.46	4.2	93	0.059
Fluridone	5.0	5.1	3.6	102	0.55
HCH, alpha	0.50	0.51	13	102	0.20
HCH, beta	0.50	0.51	20	102	0.31
HCH, delta	0.50	0.56	13	112	0.21
HCH, gamma (Lindane)	0.50	0.63	8.0	126	0.15
Heptachlor	0.50	0.41	12	83	0.15
Heptachlor Epoxide	0.50	0.35	5.5	70	0.058
2,2',3,3',4,4',6-Heptachlorobiphenyl	0.50	0.35	10	71	0.11
Hexachlorobenzene	0.50	0.39	11	78	0.13
2,2',4,4',5,6'-Hexachlorobiphenyl	0.50	0.37	9.6	73	0.11
Hexachlorocyclopentadiene	0.50	0.43	5.6	86	0.072
Hexazinone	0.50	0.70	5.0	140	0.11
Indeno[1,2,3-cd]pyrene	0.50	0.69	2.7	139	0.057
Isophorone	0.50	0.44	3.2	88	0.042
Methoxychlor	0.50	0.62	4.2	123	0.077
Methyl Paraoxon	0.50	0.57	10	115	0.17
Metolachlor	0.50	0.37	8.0	75	0.090
Metribuzin	0.50	0.49	11	97	0.16
Mevinphos	0.50	0.57	12	114	0.20
MGK 264 - Isomer a	0.33	0.39	3.4	116	0.040
MGK 264 - Isomer b	0.17	0.16	6.4	96	0.030
Molinate	0.50	0.53	5.5	105	0.087
Napropamide	0.50	0.58	3.5	116	0.060
Norflurazon	0.50	0.63	7.1	126	0.13
2,2',3,3',4,5',6,6'-Octachlorobiphenyl	0.50	0.50	8.7	101	0.13
l					
Pebulate	0.50	0.49	5.4	98	0.080
2,2',3',4,6-Pentachlorobiphenyl	0.50	0.30	16	61	0.15

TABLE 3. ACCURACY AND PRECISION DATA FROM EIGHT DETERMINATIONS OF THE METHOD ANALYTES IN REAGENT WATER USING LIQUID-SOLID C-18 CARTRIDGE EXTRACTION AND THE QUADRUPOLE MASS SPECTROMETER

Compound	True Conc. (µg/L)	Mean Observed Conc. (µg/L)	Relative Standard Deviation (%)	Mean Method Accuracy (% of True Conc.)	MDL (µg/L)
Pentachlorophenol	ND	ND	ND	ND	ND
Permethrin, cis	0.25	0.30	3.7	121	0.034
Permethrin, trans	0.75	0.82	2.7	109	0.067
Phenathrene	0.50	0.46	4.3	92	0.059
Prometon ^a	0.50	0.30	42	60	0.38
Prometryn	0.50	0.46	5.6	92	0.078
Pronamide	0.50	0.54	5.9	108	0.095
Propachlor	0.50	0.49	7.5	98	0.11
Propazine	0.50	0.54	7.1	108	0.12
Pyrene	0.50	0.38	5.7	77	0.066
Simazine	0.50	0.55	9.1	109	0.15
Simetryn	0.50	0.52	8.2	105	0.13
Stirofos	0.50	0.75	5.8	149	0.13
Tebuthiuron	5.0	6.8	14	136	2.8
Terbacil	5.0	4.9	14	97	2.1
Terbufos	0.50	0.53	6.1	106	0.096
Terbutryn	0.50	0.47	7.6	95	0.11
2,2',4,4'-Tetrachlorobiphenyl	0.50	0.36	4.1	71	0.044
Toxaphene	ND	ND	ND	ND	ND
Triademefon	0.50	0.57	20	113	0.33
2,4,5-Trichlorobiphenyl	0.50	0.38	6.7	75	0.075
Tricyclazole	5.0	4.6	19	92	2.6
Trifluralin	0.50	0.63	5.1	127	0.096
Vernolate	0.50	0.51	5.5	102	0.084

ND = Not determined.

^aData from samples extracted at pH 2 - for accurate determination of this analyte, a separate sample must be extracted at ambient pH.

TABLE 4. ACCURACY AND PRECISION DATA FROM EIGHT DETERMINATIONS OF THE METHOD ANALYTES IN REAGENT WATER USING LIQUID-SOLID C-18 DISK EXTRACTION AND THE QUADRUPOLE MASS SPECTROMETER

Compound	True Conc. (µg/L)	Mean Observed Conc. (µg/L)	Relative Standard Deviation n (%)	Mean Method Accuracy (% of True Conc.)	MDL (µg/L)
<u>Surrogates</u>					
1,3-Dimethyl-2-Nitrobenzene	5.0	4.6	2.6	93	
Perylene-d12	5.0	4.8	1.6	95	
Triphenylphosphate	5.0	5.0	2.5	101	
<u>Target Analytes</u>					
Acenaphthylene	0.50	0.47	8.4	94	0.12
Alachlor	0.50	0.50	5.8	100	0.087
Aldrin	0.50	0.39	13	78	0.16
Ametryn	0.50	0.38	28	76	0.32
Anthracene	0.50	0.49	13	98	0.18
Aroclor 1016	ND	ND	ND	ND	ND
Aroclor 1221	ND	ND	ND	ND	ND
Aroclor 1232	ND	ND	ND	ND	ND
Aroclor 1242	ND	ND	ND	ND	ND
Aroclor 1248	ND	ND	ND	ND	ND
Aroclor 1254	ND	ND	ND	ND	ND
Aroclor 1260	ND	ND	ND	ND	ND
Atraton ^a	0.50	0.07	139	19	0.29
Atrazine	0.50	0.60	3.7	119	0.065
Benz[a]anthracene	0.50	0.38	6.1	76	0.070
Benzo[b]fluoranthene	0.50	0.61	2.5	121	0.046
Benzo[k]fluoranthene	0.50	0.61	27	122	0.50
Benzo[g,h,i]perylene	0.50	0.69	1.4	138	0.029
Benzo[a]pyrene	0.50	0.58	6.1	116	0.11
Bromacil	0.50	0.49	23	99	0.34
Butachlor	0.50	0.63	2.1	127	0.039
Butylate	0.50	0.50	4.9	99	0.073
Butylbenzylphthalate	0.50	0.78	5.5	156	0.13
Carboxin	5.0	2.7	12	54	0.98
Chlordane (alpha-Chlordane)	0.50	0.37	5.5	74	0.061
Chlordane (gamma-Chlordane)	0.50	0.40	4.2	80	0.050
Chlordane (trans-Nonachlor)	0.50	0.45	7.8	90	0.11
Chlorneb	0.50	0.51	7.3	100	0.11
Chlorobenzilate	5.0	7.9	8.4	156	2.0

TABLE 4. ACCURACY AND PRECISION DATA FROM EIGHT DETERMINATIONS OF THE METHOD ANALYTES IN REAGENT WATER USING LIQUID-SOLID C-18 DISK EXTRACTION AND THE QUADRUPOLE MASS SPECTROMETER

Compound	True Conc. (µg/L)	Mean Observed Conc. (µg/L)	Relative Standard Deviation n (%)	Mean Method Accuracy (% of True Conc.)	MDL (µg/L)
2-Chlorobiphenyl	0.50	0.42	1.9	84	0.023
Chlorpropham	0.50	0.68	5.4	134	0.11
Chlorpyrifos	0.50	0.61	6.5	119	0.12
Chlorothalonil	0.50	0.59	6.5	116	0.11
Chrysene	0.50	0.35	3.6	71	0.038
Cyanazine	0.50	0.68	15	136	0.31
Cycloate	0.50	0.53	4.9	106	0.077
DCPA	0.50	0.55	4.5	110	0.073
4,4'-DDD	0.50	0.67	14	137	0.28
4,4'-DDE	0.50	0.48	4.9	96	0.070
4,4'-DDT	0.50	0.93	3.2	187	0.090
Diazinon	0.50	0.56	6.8	109	0.11
Dibenz[a,h]anthracene	0.50	0.61	15	122	0.28
Di-n-Butylphthalate	ND	ND	ND	ND	ND
2,3-Dichlorobiphenyl	0.50	0.46	8.1	93	0.11
Dichlorvos	0.50	0.54	5.6	108	0.092
Dieldrin	0.50	0.52	7.8	104	0.12
Di-(2-ethylhexyl)adipate	ND	ND	ND	ND	ND
Di(2-ethylhexyl)phthalate	ND	ND	ND	ND	ND
Diethylphthalate	0.50	0.66	10	132	0.20
Dimethylphthalate	0.50	0.57	8.3	114	0.14
2,4-Dinitrotoluene	0.50	0.54	5.7	109	0.093
2,6-Dinitrotoluene	0.50	0.48	4.9	96	0.071
Diphenamid	0.50	0.60	3.8	118	0.067
Disulfoton	5.0	4.8	9.4	96	1.3
Disulfoton Sulfone	0.50	0.82	2.8	164	0.070
Disulfoton Sulfoxide	0.50	0.68	8.9	136	0.18
Endosulfan I	0.50	0.65	10	132	0.20
Endosulfan II	0.50	0.60	21	122	0.38
Endosulfan Sulfate	0.50	0.67	6.1	133	0.12
Endrin	0.50	0.58	18	116	0.31
Endrin Aldehyde	0.50	0.51	16	101	0.24
EPTC	0.50	0.50	3.8	100	0.056
Ethoprop	0.50	0.69	2.3	138	0.048
Etridiazole	0.50	0.74	4.0	149	0.090

TABLE 4. ACCURACY AND PRECISION DATA FROM EIGHT DETERMINATIONS OF THE METHOD ANALYTES IN REAGENT WATER USING LIQUID-SOLID C-18 DISK EXTRACTION AND THE QUADRUPOLE MASS SPECTROMETER

Compound	True Conc. (µg/L)	Mean Observed Conc. (µg/L)	Relative Standard Deviation n (%)	Mean Method Accuracy (% of True Conc.)	MDL (µg/L)
Fenamiphos	5.0	6.3	8.8	124	1.6
Fenarimol	5.0	7.5	5.5	150	1.2
Fluorene	0.50	0.47	8.1	94	0.11
Fluridone	5.0	5.7	4.5	114	0.77
HCH, alpha	0.50	0.54	12	107	0.20
HCH, beta	0.50	0.57	17	112	0.28
HCH, delta	0.50	0.61	8.2	120	0.15
HCH, gamma (Lindane)	0.50	0.62	6.6	124	0.12
Heptachlor	0.50	0.40	12	80	0.14
Heptachlor Epoxide	0.50	0.36	8.7	71	0.093
2,2',3,3',4,4',6-Heptachlorobiphenyl	0.50	0.36	13	71	0.14
Hexachlorobenzene	0.50	0.47	8.3	95	0.12
2,2',4,4',5,6'-Hexachlorobiphenyl	0.50	0.41	11	83	0.13
Hexachlorocyclopentadiene	0.50	0.42	12	84	0.16
Hexazinone	0.50	0.85	5.6	169	0.14
Indeno[1,2,3-cd]pyrene	0.50	0.69	2.4	138	0.050
Isophorone	0.50	0.41	4.2	83	0.052
Methoxychlor	0.50	0.58	1.9	117	0.033
Methyl Paraoxon	0.50	0.62	14	122	0.25
Metolachlor	0.50	0.38	7.5	75	0.084
Metribuzin	0.50	0.54	3.9	107	0.062
Mevinphos	0.50	0.72	3.7	143	0.079
MGK 264 - Isomer a	0.33	0.40	8.8	119	0.10
MGK 264 - Isomer b	0.17	0.17	5.9	103	0.030
Molinate	0.50	0.53	3.2	105	0.050
Napropamide	0.50	0.64	5.9	126	0.11
Norflurazon	0.50	0.70	4.2	141	0.089
2,2',3,3',4,5',6,6'-Octachlorobiphenyl	0.50	0.51	4.2	102	0.064
Pebulate	0.50	0.48	5.8	96	0.084
2,2',3',4,6-Pentachlorobiphenyl	0.50	0.35	4.2	70	0.044
Pentachlorophenol	2.0	1.9	16	95	.89
Permethrin,cis	0.25	0.32	3.3	126	0.031
Permethrin,trans	0.75	0.89	1.9	118	0.051

TABLE 4. ACCURACY AND PRECISION DATA FROM EIGHT DETERMINATIONS OF THE METHOD ANALYTES IN REAGENT WATER USING LIQUID-SOLID C-18 DISK EXTRACTION AND THE QUADRUPOLE MASS SPECTROMETER

Compound	True Conc. (µg/L)	Mean Observed Conc. (µg/L)	Relative Standard Deviation n (%)	Mean Method Accuracy (% of True Conc.)	MDL (µg/L)
Phenathrene	0.50	0.48	5.0	95	0.071
Prometon ^a	0.50	0.21	66	45	0.44
Prometryn	0.50	0.46	24	93	0.33
Pronamide	0.50	0.58	7.1	113	0.12
Propachlor	0.50	0.49	5.4	98	0.079
Propazine	0.50	0.59	5.0	117	0.088
Pyrene	0.50	0.40	3.2	79	0.038
Simazine	0.50	0.60	10	120	0.18
Simetryn	0.50	0.41	15	83	0.19
Stirofos	0.50	0.84	3.2	168	0.081
Tebuthiuron	5.0	9.3	8.6	187	2.4
Terbacil	5.0	5.0	11	100	1.7
Terbufos	0.50	0.62	4.2	123	0.077
Terbutryn	0.50	0.46	23	94	0.32
2,2',4,4'-Tetrachlorobiphenyl	0.50	0.40	7.4	79	0.088
Toxaphene	ND	ND	ND	ND	ND
Triademefon	0.50	0.73	7.2	145	0.16
2,4,5-Trichlorobiphenyl	0.50	0.44	5.3	89	0.071
Tricyclazole	5.0	6.8	12	137	2.4
Trifluralin	0.50	0.62	2.6	124	0.048
Vernolate	0.50	0.51	3.4	100	0.051

ND = Not determined.

^aData from samples extracted at pH 2 - for accurate determination of this analyte, a separate sample must be extracted at ambient pH.

TABLE 5. ACCURACY AND PRECISION DATA FROM EIGHT DETERMINATIONS OF THE METHOD ANALYTES IN REAGENT WATER USING LIQUID-SOLID C-18 CARTRIDGE EXTRACTION AND THE ION TRAP MASS SPECTROMETER

Compound	True Conc. (µg/L)	Mean Observed Conc. (µg/L)	Relative Standard Deviation n (%)	Mean Method Accuracy (% of True Conc.)	MDL (µg/L)
<u>Surrogates</u>					
1,3-Dimethyl-2-Nitrobenzene	5.0	4.9	8.4	98	
Perylene-d12	5.0	4.3	18	86	
Triphenylphosphate	5.0	4.8	13	96	
<u>Target Analytes</u>					
Acenaphthylene	0.50	0.50	8.8	100	0.13
Alachlor	0.50	0.58	4.0	115	0.069
Aldrin	0.50	0.42	3.5	85	0.045
Ametryn	0.50	0.46	3.3	91	0.045
Anthracene	0.50	0.42	3.8	84	0.048
Aroclor 1016	1.0	1.1	4.4	113	0.15
Aroclor 1221	ND	ND	ND	ND	ND
Aroclor 1232	ND	ND	ND	ND	ND
Aroclor 1242	ND	ND	ND	ND	ND
Aroclor 1248	ND	ND	ND	ND	ND
Aroclor 1254 ^a	1.0	1.1	17	110	0.56
Aroclor 1260	1.0	0.96	9.3	96	0.27
Atraton ^c	0.50	0.35	11	70	0.12
Atrazine	0.50	0.55	5.0	109	0.081
Benz[a]anthracene	0.50	0.43	7.3	85	0.093
Benzo[b]fluoranthene	0.50	0.44	16	88	0.21
Benzo[k]fluoranthene	0.50	0.34	22	68	0.23
Benzo[g,h,i]perylene	0.50	0.38	31	76	0.35
Benzo[a]pyrene	0.50	0.36	21	73	0.23
Bromacil	0.50	0.45	9.1	90	0.12
Butachlor	0.50	0.67	12	133	0.24
Butylate	0.50	0.52	5.2	104	0.082
Butylbenzylphthalate ^b	5.0	5.7	7.7	114	1.4
Carboxin	0.50	0.58	22	117	0.38
Chlordane, (alpha-Chlordane)	0.50	0.47	12	95	0.17
Chlordane, (gamma-Chlordane)	0.50	0.50	10	99	0.16
Chlordane, (trans-Nonachlor)	0.50	0.48	11	96	0.16

TABLE 5. ACCURACY AND PRECISION DATA FROM EIGHT DETERMINATIONS OF THE METHOD ANALYTES IN REAGENT WATER USING LIQUID-SOLID C-18 CARTRIDGE EXTRACTION AND THE ION TRAP MASS SPECTROMETER

Compound	True Conc. (µg/L)	Mean Observed Conc. (µg/L)	Relative Standard Deviation n (%)	Mean Method Accuracy (% of True Conc.)	MDL (µg/L)
Chlorneb	0.50	0.51	8.1	103	0.13
Chlorobenzilate	0.50	0.61	9.7	123	0.17
2-Chlorobiphenyl	0.50	0.47	4.8	94	0.068
Chlorpropham	0.50	0.55	8.1	109	0.13
Chlorpyrifos	0.50	0.50	2.4	99	0.035
Chlorothalonil	0.50	0.62	5.3	123	0.098
Chrysene	0.50	0.50	9.2	99	0.14
Cyanazine	0.50	0.49	13	97	0.19
Cycloate	0.50	0.52	7.6	103	0.12
DCPA	0.50	0.55	7.2	109	0.12
4,4'-DDD	0.50	0.52	3.6	103	0.055
4,4'-DDE	0.50	0.41	5.8	81	0.070
4,4'-DDT	0.50	0.54	2.4	108	0.039
Diazinon	0.50	0.37	2.7	75	0.030
Dibenz[a,h]anthracene	0.50	0.37	29	74	0.32
Di-n-Butylphthalate ^b	5.0	6.2	4.6	124	0.89
2,3-Dichlorobiphenyl	0.50	0.45	5.8	90	0.079
Dichlorvos	0.50	0.53	8.0	106	0.13
Dieldrin	0.50	0.50	10	100	0.15
Di(2-Ethylhexyl)adipate	0.50	0.59	18	117	0.31
Di(2-Ethylhexyl)phthalate ^b	5.0	6.5	6.6	130	1.3
Diethylphthalate	0.50	0.63	15	126	0.28
Dimethylphthalate	0.50	0.51	9.5	102	0.14
2,4-Dinitrotoluene	0.50	0.45	18	91	0.24
2,6-Dinitrotoluene	0.50	0.40	17	80	0.20
Diphenamid	0.50	0.55	6.5	111	0.11
Disulfoton	0.50	0.62	9.8	124	0.18
Disulfoton Sulfone	0.50	0.64	3.5	128	0.068
Disulfoton Sulfoxide	0.50	0.57	8.6	114	0.15
Endosulfan I	0.50	0.60	6.1	121	0.11
Endosulfan II	0.50	0.64	3.9	128	0.074
Endosulfan Sulfate	0.50	0.58	5.4	116	0.093
Endrin	0.50	0.62	18	124	0.34
Endrin Aldehyde	0.50	0.58	8.7	116	0.15
EPTC	0.50	0.53	7.7	105	0.12

TABLE 5. ACCURACY AND PRECISION DATA FROM EIGHT DETERMINATIONS OF THE METHOD ANALYTES IN REAGENT WATER USING LIQUID-SOLID C-18 CARTRIDGE EXTRACTION AND THE ION TRAP MASS SPECTROMETER

Compound	True Conc. (µg/L)	Mean Observed Conc. (µg/L)	Relative Standard Deviation n (%)	Mean Method Accuracy (% of True Conc.)	MDL (µg/L)
Ethoprop	0.50	0.62	10	124	0.19
Etridiazole	0.50	0.61	6.5	122	0.12
Fenamiphos	0.50	0.67	12	133	0.24
Fenarimol	0.50	0.74	11	148	0.25
Fluorene	0.50	0.49	9.0	98	0.13
Fluridone	5.0	5.2	2.5	105	0.39
HCH, alpha	0.50	0.55	6.8	109	0.11
HCH, beta	0.50	0.54	5.3	107	0.085
HCH, delta	0.50	0.52	3.1	105	0.049
HCH, gamma (Lindane)	0.50	0.53	5.3	105	0.084
Heptachlor	0.50	0.50	4.1	100	0.061
Heptachlor Epoxide	0.50	0.54	8.2	108	0.13
2,2',3,3',4,4',6-Heptachloro-biphenyl	0.50	0.45	11	90	0.15
Hexachlorobenzene	0.50	0.41	6.0	82	0.074
2,2',4,4',5,6'-Hexachloro-biphenyl	0.50	0.40	15	80	0.18
Hexachlorocyclopentadiene	0.50	0.34	13	68	0.13
Hexazinone	0.50	0.80	5.6	159	0.14
Indeno[1,2,3-cd]pyrene	0.50	0.36	28	71	0.30
Isophorone	0.50	0.54	7.9	107	0.13
Methoxychlor	0.50	0.58	7.7	115	0.13
Methyl Paraoxon	0.50	0.85	3.7	170	0.094
Metolachlor	0.50	0.58	4.8	117	0.085
Metribuzin	0.50	0.54	14	108	0.22
Mevinphos	0.50	0.47	12	95	0.17
MGK 264 - Isomer a	0.33	0.38	9.5	113	0.11
MGK 264 - Isomer b	0.16	0.18	5.4	105	0.029
Molinate	0.50	0.55	5.2	111	0.086
Napropamide	0.50	0.63	10	127	0.20
Norflurazon	0.50	0.82	3.8	165	0.093
2,2',3,3',4,5',6,6'-Octachloro-biphenyl	0.50	0.49	19	99	0.28
Pebulate	0.50	0.56	6.1	112	0.10

TABLE 5. ACCURACY AND PRECISION DATA FROM EIGHT DETERMINATIONS OF THE METHOD ANALYTES IN REAGENT WATER USING LIQUID-SOLID C-18 CARTRIDGE EXTRACTION AND THE ION TRAP MASS SPECTROMETER

Compound	True Conc. (µg/L)	Mean Observed Conc. (µg/L)	Relative Standard Deviation (%)	Mean Method Accuracy (% of True Conc.)	MDL (µg/L)
2,2',3',4,6-Pentachlorobiphenyl	0.50	0.43	8.7	86	0.11
Pentachlorophenol	2.0	2.4	10	119	0.72
Permethrin,cis	0.25	0.45	3.2	179	0.043
Permethrin,trans	0.75	1.1	2.2	153	0.074
Phenanthrene	0.50	0.48	4.8	96	0.069
Prometon ^c	0.50	0.24	27	48	0.20
Prometryn	0.50	0.46	3.0	92	0.041
Pronamide	0.50	0.56	5.3	113	0.089
Propachlor	0.50	0.56	8.6	112	0.14
Propazine	0.50	0.52	4.3	103	0.066
Pyrene	0.50	0.47	11	95	0.16
Simazine	0.50	0.48	8.8	96	0.13
Simetryn	0.50	0.48	2.9	96	0.042
Stirofos	0.50	0.80	3.9	160	0.093
Tebuthiuron	0.50	0.67	7.4	134	0.15
Terbacil	0.50	0.59	12	119	0.22
Terbufos	0.50	0.46	11	92	0.15
Terbutryn	0.50	0.48	2.6	97	0.038
2,2',4,4'-Tetrachlorobiphenyl	0.50	0.40	6.4	81	0.077
Toxaphene	10	11	4.9	118	1.7
Triademefon	0.50	0.73	6.4	146	0.14
2,4,5-Trichlorobiphenyl	0.50	0.44	3.3	88	0.043
Tricyclazole	0.50	0.63	16	127	0.31
Trifluralin	0.50	0.62	13	124	0.24
Vernolate	0.50	0.50	9.3	101	0.14

^aSeven replicates.

^bSeven replicates in fortified tap water.

^cData from samples extracted at pH 2 - for accurate determination of this analyte, a separate sample must be extracted at ambient pH.

TABLE 6. ACCURACY AND PRECISION DATA FROM EIGHT DETERMINATIONS OF THE METHOD ANALYTES IN REAGENT WATER USING LIQUID-SOLID C-18 DISK EXTRACTION AND THE ION TRAP MASS SPECTROMETER

Compound	True Conc. (µg/L)	Mean Observed Conc. (µg/L)	Relative Standard Deviation n (%)	Mean Method Accuracy (% of True Conc.)	MDL (µg/L)
<u>Surrogates</u>					
1,3-dimethyl-2-nitrobenzene	5.0	4.9	10	98	
perylene-d12	5.0	4.9	4.5	98	
triphenylphosphate	5.0	5.9	8.1	117	
<u>Target Analytes</u>					
Acenaphthylene	0.50	0.51	4.5	102	0.068
Alachlor	0.50	0.54	6.6	108	0.11
Aldrin	0.50	0.45	6.3	90	0.085
Ametryn	0.50	0.41	23	82	0.29
Anthracene	0.50	0.39	15	79	0.18
Aroclor 1016	0.20	0.25	4.7	123	0.040
Aroclor 1221	0.20	0.26	6.1	130	0.054
Aroclor 1232	0.20	0.24	4.7	121	0.042
Aroclor 1242	0.20	0.26	4.9	129	0.043
Aroclor 1248	0.20	0.24	4.1	118	0.038
Aroclor 1254	0.20	0.22	3.7	110	0.028
Aroclor 1260 ^a	0.20	0.21	2.2	108	0.018
Atraton ^d	0.50	0.10	46	21	0.14
Atrazine	0.50	0.56	4.6	111	0.076
Benz[a]anthracene	0.50	0.44	7.4	88	0.098
Benzo[b]fluoranthene	0.50	0.50	9.1	100	0.14
Benzo[k]fluoranthene	0.50	0.46	2.2	91	0.031
Benzo[g,h,i]perylene	0.50	0.47	7.9	95	0.11
Benzo[a]pyrene	0.50	0.44	12	89	0.16
Bromacil	0.50	0.49	4.4	99	0.066
Butachlor	0.50	0.66	5.1	132	0.10
Butylate	0.50	0.50	5.4	100	0.082
Butylbenzylphthalate ^b	5.0	5.7	7.7	114	1.4
Carboxin	0.50	0.40	38.1	79	0.45
Chlordane, (alpha-Chlordane)	0.50	0.50	4.3	101	0.065
Chlordane, (gamma-Chlordane)	0.50	0.51	7.2	102	0.11
Chlordane, (trans-Nonachlor)	0.50	0.52	6.2	104	0.097
Chlorneb	0.50	0.54	6.3	108	0.10

TABLE 6. ACCURACY AND PRECISION DATA FROM EIGHT DETERMINATIONS OF THE METHOD ANALYTES IN REAGENT WATER USING LIQUID-SOLID C-18 DISK EXTRACTION AND THE ION TRAP MASS SPECTROMETER

Compound	True Conc. (µg/L)	Mean Observed Conc. (µg/L)	Relative Standard Deviation (%)	Mean Method Accuracy (% of True Conc.)	MDL (µg/L)
Chlorobenzilate	0.50	0.59	9.7	117	0.17
2-Chlorobiphenyl	0.50	0.50	4.7	100	0.070
Chlorpropham	0.50	0.55	4.7	111	0.079
Chlorpyrifos	0.50	0.54	11	109	0.18
Chlorothalonil	0.50	0.59	4.4	119	0.079
Chrysene	0.50	0.48	6.1	96	0.088
Cyanazine	0.50	0.52	8.3	105	0.13
Cycloate	0.50	0.51	4.1	102	0.063
DCPA	0.50	0.53	3.2	105	0.051
4,4'-DDD	0.50	0.63	16	127	0.31
4,4'-DDE	0.50	0.48	3.7	96	0.054
4,4'-DDT	0.50	0.58	7.2	117	0.13
Diazinon	0.50	0.50	4.5	101	0.068
Dibenz[a,h]anthracene	0.50	0.47	9.9	94	0.14
Di-n-Butylphthalate ^b	5.0	5.7	3.3	115	0.59
2,3-Dichlorobiphenyl	0.50	0.50	2.6	100	0.039
Dichlorvos	0.50	0.50	8.7	99	0.13
Dieldrin	0.50	0.53	7.0	106	0.11
Di(2-Ethylhexyl)adipate ^b	5.0	5.4	7.5	107	1.3
Di(2-Ethylhexyl)phthalate ^b	5.0	5.7	2.6	114	0.46
Diethylphthalate	0.50	0.68	5.0	137	0.10
Dimethylphthalate	0.50	0.51	5.0	102	0.077
2,4-Dinitrotoluene	0.50	0.30	8.1	59	0.072
2,6-Dinitrotoluene	0.50	0.28	6.4	56	0.054
Diphenamid	0.50	0.56	6.4	112	0.11
Disulfoton	0.50	0.70	5.3	139	0.11
Disulfoton Sulfone	0.50	0.64	5.9	128	0.11
Disulfoton Sulfoxide	0.50	0.60	3.8	119	0.068
Endosulfan I	0.50	0.61	4.9	122	0.089
Endosulfan II	0.50	0.66	6.1	131	0.12
Endosulfan Sulfate	0.50	0.57	9.0	115	0.16
Endrin	0.50	0.68	7.9	137	0.16
Endrin Aldehyde	0.50	0.57	2.8	114	0.048
EPTC	0.50	0.48	5.2	97	0.076
Ethoprop	0.50	0.61	7.5	122	0.14

TABLE 6. ACCURACY AND PRECISION DATA FROM EIGHT DETERMINATIONS OF THE METHOD ANALYTES IN REAGENT WATER USING LIQUID-SOLID C-18 DISK EXTRACTION AND THE ION TRAP MASS SPECTROMETER

Compound	True Conc. (µg/L)	Mean Observed Conc. (µg/L)	Relative Standard Deviation n (%)	Mean Method Accuracy (% of True Conc.)	MDL (µg/L)
Etridiazole	0.50	0.54	4.2	108	0.067
Fenamiphos	0.50	0.67	10	133	0.20
Fenarimol	0.50	0.59	5.8	118	0.10
Fluorene	0.50	0.53	3.4	106	0.054
Fluridone	5.0	5.2	2.3	104	0.16
HCH, alpha	0.50	0.55	5.0	110	0.083
HCH, beta	0.50	0.54	4.1	109	0.068
HCH, delta	0.50	0.53	3.6	106	0.058
HCH, gamma (Lindane)	0.50	0.50	3.2	100	0.047
Heptachlor	0.50	0.49	4.0	98	0.059
Heptachlor Epoxide	0.50	0.50	3.2	100	0.048
2,2',3,3',4,4',6-Heptachloro-biphenyl	0.50	0.46	7.3	92	0.10
Hexachlorobenzene	0.50	0.49	3.4	97	0.049
2,2',4,4',5,6'-Hexachlorobiphenyl	0.50	0.50	5.3	99	0.079
Hexachlorocyclopentadiene	0.50	0.37	9.3	73	0.10
Hexazinone	0.50	0.75	4.2	150	0.094
Indeno[1,2,3-cd]pyrene	0.50	0.48	7.3	96	0.10
Isophorone	0.50	0.51	4.3	102	0.066
Methoxychlor	0.50	0.52	6.7	104	0.10
Methyl Paraoxon	0.50	0.75	4.5	151	0.10
Metolachlor	0.50	0.57	3.2	114	0.054
Metribuzin	0.50	0.53	5.7	107	0.090
Mevinphos	0.50	0.56	6.2	112	0.10
MGK 264 - Isomer a	0.33	0.38	6.7	113	0.076
MGK 264 - Isomer b	0.16	0.18	5.3	110	0.029
Molinate	0.50	0.53	3.8	105	0.060
Napropamide	0.50	0.58	7.9	116	0.14
Norflurazon	0.50	0.71	4.3	142	0.091
2,2',3,3',4,5',6,6'-Octachlorobiphenyl	0.50	0.47	5.3	94	0.076
Pebulate	0.50	0.56	7.1	112	0.11
2,2',3',4,6-Pentachlorobiphenyl	0.50	0.49	4.0	97	0.059
Pentachlorophenol	2.0	2.2	15	111	1.0
Permethrin, cis	0.25	0.37	3.1	149	0.035

TABLE 6. ACCURACY AND PRECISION DATA FROM EIGHT DETERMINATIONS OF THE METHOD ANALYTES IN REAGENT WATER USING LIQUID-SOLID C-18 DISK EXTRACTION AND THE ION TRAP MASS SPECTROMETER

Compound	True Conc. (µg/L)	Mean Observed Conc. (µg/L)	Relative Standard Deviation n (%)	Mean Method Accuracy (% of True Conc.)	MDL (µg/L)
Permethrin,trans	0.75	0.84	1.6	112	0.039
Phenanthrene	0.50	0.49	6.3	97	0.092
Prometon ^d	0.50	0.16	63	32	0.30
Prometryn	0.50	0.46	23	91	0.32
Pronamide	0.50	0.56	3.9	111	0.064
Propachlor	0.50	0.58	5.7	115	0.098
Propazine	0.50	0.53	4.7	106	0.074
Pyrene	0.50	0.52	5.2	104	0.080
Simazine	0.50	0.54	2.8	107	0.045
Simetryn	0.50	0.36	20	71	0.22
Stirofos	0.50	0.72	3.7	144	0.080
Tebuthiuron	0.50	0.67	7.9	133	0.16
Terbacil	0.50	0.64	12	129	0.23
Terbufos	0.50	0.57	6.8	113	0.11
Terbutryn	0.50	0.46	24	93	0.34
2,2',4,4'-Tetrachlorobiphenyl	0.50	0.46	7.4	91	0.10
Toxaphene ^c	10	12	2.7	122	1.0
Triademefon	0.50	0.71	7.3	142	0.16
2,4,5-Trichlorobiphenyl	0.50	0.48	4.5	97	0.066
Tricyclazole	0.50	0.65	14	130	0.27
Trifluralin	0.50	0.59	7.8	117	0.14
Vernolate	0.50	0.50	3.2	99	0.047

^aSix replicates.

^bSeven replicates in fortified tap water.

^cSeven replicates.

^dData from samples extracted at pH 2 - for accurate determination of this analyte, a separate sample must be extracted at ambient pH.

TABLE 7. ACCURACY AND PRECISION DATA FROM EIGHT DETERMINATIONS AT 5 µg/L IN REAGENT WATER OF POORLY CHROMATOGRAPHED NITROGEN AND PHOSPHOROUS CONTAINING PESTICIDES

Compound	Ion Trap Mass Spectrometer					Quadrupole Mass Spectrometer				
	Cartridge		Disk		Mean Method Accuracy (% of True Conc.)	Cartridge		Disk		Mean Method Accuracy (% of True Conc.)
	Relative Standard Deviation (%)	Mean Method Accuracy (% of True Conc.)	Relative Standard Deviation (%)	Mean Method Accuracy (% of True Conc.)		Relative Standard Deviation (%)	Mean Method Accuracy (% of True Conc.)	Relative Standard Deviation (%)	Mean Method Accuracy (% of True Conc.)	
Fenamiphos	7.7	99	4.5	108	6.1	103	8.8	124		
Fenarimol	2.0	104	10	110	6.5	126	5.5	150		
Fluridone	2.5	105	2.3	104	3.6	102	4.5	114		
Hexazinone	4.2	106	9.7	116	5.3	104	8.3	127		
Norflurazon	4.1	111	9.6	119	3.2	98	11.1	113		
Stirofos	8.2	114	12	124	4.1	110	11.1	125		
Tebuthiuron	9.5	119	5.3	145	13	136	8.6	182		
Triademeton	7.8	113	10	128	3.7	100	9.8	118		
Tricyclazole	16	81	9.5	99	19	92	12	137		

TABLE 8. ACCURACY AND PRECISION DATA FROM SEVEN DETERMINATIONS OF THE METHOD ANALYTES IN TAP WATER USING LIQUID-SOLID C-18 CARTRIDGE EXTRACTION AND THE ION TRAP MASS SPECTROMETER

Compound	True Conc.	Mean	% RSD	% REC
Acenaphthylene	5.0	5.2	5.3	104
Alachlor	5.0	5.5	6.9	110
Aldrin	5.0	4.4	14	88
Ametryn	5.0	4.2	3.4	83
Anthracene	5.0	4.3	5.2	87
Aroclor 1016	ND	ND	ND	ND
Aroclor 1221	ND	ND	ND	ND
Aroclor 1232	ND	ND	ND	ND
Aroclor 1242	ND	ND	ND	ND
Aroclor 1248	ND	ND	ND	ND
Aroclor 1254	ND	ND	ND	ND
Aroclor 1260	ND	ND	ND	ND
Atraton ^a	5.0	2.2	28	43
Atrazine	5.0	5.6	6.2	111
Benz[a]anthracene	5.0	4.9	8.8	97
Benzo[b]fluoranthene	5.0	5.7	7.5	114
Benzo[k]fluoranthene	5.0	5.7	2.9	113
Benzo[g,h,i]perylene	5.0	5.6	7.1	113
Benzo[a]pyrene	5.0	6.1	4.6	121
Bromacil	5.0	3.5	5.1	69
Butachlor	5.0	5.4	7.5	109
Butylate	5.0	5.1	4.5	102
Butylbenzylphthalate	5.0	7.2	8.3	144
Carboxin	5.0	1.0	23	20
Chlordane, (alpha-Chlordane)	5.0	5.2	8.9	104
Chlordane, (gamma-Chlordane)	5.0	5.1	8.0	102
Chlordane, (trans-Nonachlor)	5.0	5.6	7.4	111
Chlorneb	5.0	5.2	3.0	105
Chlorobenzilate	5.0	5.7	4.4	114
2-Chlorobiphenyl	5.0	5.8	5.4	115
Chlorpropham	5.0	6.3	4.9	127
Chlorpyrifos	5.0	5.3	7.2	107
Chlorthalonil	5.0	5.4	9.9	108
Chrysene	5.0	5.5	3.9	110
Cyanazine	5.0	6.1	13	122
Cycloate	5.0	5.6	1.5	112
DCPA	5.0	5.4	5.0	107
4,4'-DDD	5.0	5.3	6.5	105

TABLE 8. ACCURACY AND PRECISION DATA FROM SEVEN DETERMINATIONS OF THE METHOD ANALYTES IN TAP WATER USING LIQUID-SOLID C-18 CARTRIDGE EXTRACTION AND THE ION TRAP MASS SPECTROMETER

Compound	True Conc.	Mean	% RSD	% REC
4,4'-DDE	5.0	5.2	6.6	104
4,4'-DDT	5.0	5.6	9.6	111
Diazinon	5.0	4.9	8.7	98
Dibenz[a,h]anthracene	5.0	5.9	7.5	118
Di-n-Butylphthalate	5.0	6.2	4.6	124
2,3-Dichlorobiphenyl	5.0	5.3	7.4	106
Dichlorvos	5.0	2.8	7.3	56
Dieldrin	5.0	5.3	7.2	105
Di(2-Ethylhexyl)adipate	5.0	6.7	10	134
Di(2-Ethylhexyl)phthalate	5.0	6.5	6.6	130
Diethylphthalate	5.0	6.4	7.4	127
Dimethylphthalate	5.0	5.8	7.1	116
2,4-Dinitrotoluene	5.0	4.2	8.7	84
2,6-Dinitrotoluene	5.0	4.1	8.5	82
Diphenamid	5.0	5.2	7.7	104
Disulfoton	5.0	2.5	33	50
Disulfoton Sulfone	5.0	5.5	7.4	110
Disulfoton Sulfoxide	5.0	9.4	11	188
Endosulfan I	5.0	5.5	11	109
Endosulfan II	5.0	5.3	9.6	106
Endosulfan Sulfate	5.0	5.3	7.8	106
Endrin	5.0	6.1	3.9	121
Endrin Aldehyde	5.0	5.1	9.1	102
EPTC	5.0	5.1	2.1	102
Ethoprop	5.0	6.3	4.2	125
Etridiazole	5.0	5.8	7.5	117
Fenamiphos	5.0	5.9	22	119
Fenarimol	5.0	7.1	3.3	141
Fluorene	5.0	5.7	5.2	114
Fluridone	5.0	6.2	9.0	125
HCH, alpha	5.0	5.9	2.6	118
HCH, beta	5.0	5.3	8.4	106
HCH, delta	5.0	5.3	5.2	106
HCH, gamma (Lindane)	5.0	5.3	6.9	107
Heptachlor	5.0	4.7	8.7	93
Heptachlor Epoxide	5.0	5.2	7.7	105
2,2',3,3',4,4',6-Heptachlorobiphenyl	5.0	5.1	6.9	103
Hexachlorobenzene	5.0	4.6	7.4	93

TABLE 8. ACCURACY AND PRECISION DATA FROM SEVEN DETERMINATIONS OF THE METHOD ANALYTES IN TAP WATER USING LIQUID-SOLID C-18 CARTRIDGE EXTRACTION AND THE ION TRAP MASS SPECTROMETER

Compound	True Conc.	Mean	% RSD	% REC
2,2',4,4',5,6'-Hexachlorobiphenyl	5.0	5.6	8.1	112
Hexachlorocyclopentadiene	5.0	6.0	4.8	120
Hexazinone	5.0	6.9	6.3	138
Indeno[1,2,3-cd]pyrene	5.0	6.8	7.7	135
Isophorone	5.0	4.9	12	99
Methoxychlor	5.0	5.6	4.9	112
Methyl Paraoxon	5.0	5.6	11	111
Metolachlor	5.0	5.6	7.7	111
Metribuzin	5.0	2.1	5.8	42
Mevinphos	5.0	3.3	1.6	67
MGK 264 - Isomer a	3.3	3.6	6.2	107
MGK 264 - Isomer b	1.7	1.8	7.6	110
Molinate	5.0	5.5	1.5	110
Napropamide	5.0	5.3	8.9	106
Norflurazon	5.0	6.7	7.2	135
2,2',3,3',4,5',6,6'-Octaclorobiphenyl	5.0	4.9	6.9	97
Pebulate	5.0	5.3	3.1	106
2,2',3',4,6-Pentachlorobiphenyl	5.0	5.3	8.1	107
Pentachlorophenol	20.	33	4.9	162
Permethrin, cis	5.0	3.3	3.5	130
Permethrin, trans	5.0	8.5	2.2	113
Phenanthrene	5.0	5.5	4.0	109
Prometona ^a	5.0	2.0	25	40
Prometryn	5.0	4.5	4.3	89
Pronamide	5.0	5.7	5.3	115
Propachlor	5.0	6.2	4.0	124
Propazine	5.0	5.6	4.9	113
Pyrene	5.0	5.2	6.7	104
Simazine	5.0	6.0	9.0	120
Simetryn	5.0	3.9	7.0	78
Stirofos	5.0	6.1	12	121
Tebuthiuron	5.0	6.5	9.7	130
Terbacil	5.0	4.0	5.5	79
Terbufos	5.0	4.5	8.4	90
Terbutryn	5.0	4.3	6.5	86
2,2',4,4'-Tetrachlorobiphenyl	5.0	5.3	4.3	106
Toxaphene	ND	ND	ND	ND
Triademefon	5.0	6.0	12	121

TABLE 8. ACCURACY AND PRECISION DATA FROM SEVEN DETERMINATIONS OF THE METHOD ANALYTES IN TAP WATER USING LIQUID-SOLID C-18 CARTRIDGE EXTRACTION AND THE ION TRAP MASS SPECTROMETER

Compound	True Conc.	Mean	% RSD	% REC
2,4,5-Trichlorobiphenyl	5.0	5.2	5.1	103
Tricyclazole	5.0	4.8	5.2	96
Trifluralin	5.0	5.9	7.8	119
Vernolate	5.0	5.4	3.3	108

^aData from samples extracted at pH 2 - for accurate determination of this analyte, a separate sample must be extracted at ambient pH.

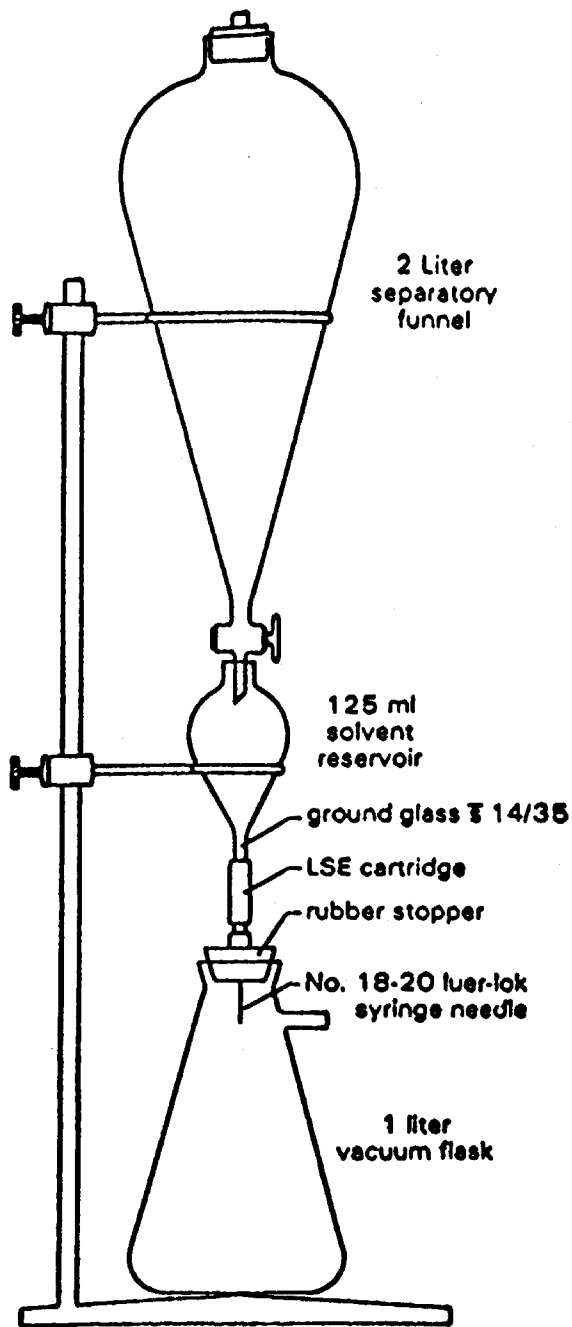

A. Extraction apparatus

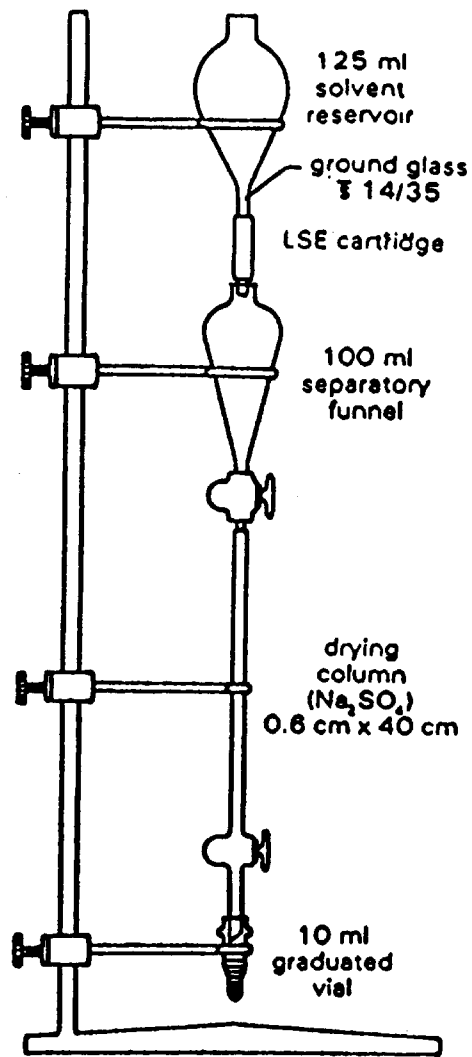

B. Elution apparatus

FIGURE 1. CARTRIDGE EXTRACTION APPARATUS

